



LEADER SIPPLE SUGAR MAKER



Leader Evaporator Co., Inc.

49 Jonergin Drive

Swanton, Vermont 05488

(802) 868-5444

www.leaderevaporator.com

TABLE OF CONTENTS

EQUIPMENT DESCRIPTION	3
SETUP AND GENERAL USE OF THE SIPPLE SUGAR MAKER	4
MAKING MAPLE CANDY	6
PREPARATION OF MOLDS.....	6
SELECTING THE MAPLE SYRUP.....	6
MAKING THE CANDY.....	6
MAKING MAPLE CREAM	8
SELECTING THE MAPLE SYRUP.....	8
MAKING THE CREAM	8
MAINTENANCE	9
AFTER EACH USE.....	9
PERIODIC	9
FURTHER INFORMATION	9
FEEDBACK	10
ATTACHMENT #1: OPERATIONAL SUPPLIES, SPARE AND REPLACEMENT PARTS	11
REPLACEMENT PARTS.....	14
ADDITIONAL REPLACEMENT PARTS.....	14
EQUIPMENT DESCRIPTION	3
SETUP AND GENERAL USE OF THE SIPPLE SUGAR MAKER	4
MAKING MAPLE CANDY	6
PREPARATION OF MOLDS.....	6
SELECTING THE MAPLE SYRUP.....	6
MAKING THE CANDY.....	6
MAKING MAPLE CREAM	8
SELECTING THE MAPLE SYRUP.....	8
MAKING THE CREAM	8
MAINTENANCE	9
AFTER EACH USE.....	9
PERIODIC	9
FURTHER INFORMATION	9
FEEDBACK	10
ATTACHMENT #1: OPERATIONAL SUPPLIES, SPARE AND REPLACEMENT PARTS	11
REPLACEMENT PARTS.....	14
ADDITIONAL REPLACEMENT PARTS.....	14

DESCRIPTION

Processing of maple syrup by boiling and agitating makes it thicken to form maple candy and other maple products. Products, like maple candy, offer the producer a way of increasing profits from maple syrup. The Sipple Sugar Maker is an excellent system for turning maple syrup into maple candy and maple cream. The LEADER EVAPORATOR Sipple Sugar Maker is a high quality machine with the main parts constructed of stainless steel.

EQUIPMENT DESCRIPTION

The Sipple Sugar Maker consists of the following parts; base with motor, "pig", trough, worm, slide gate and 4-way spider.

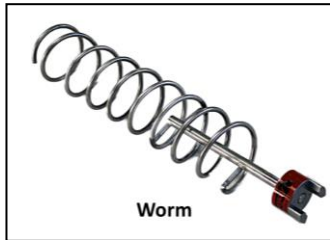
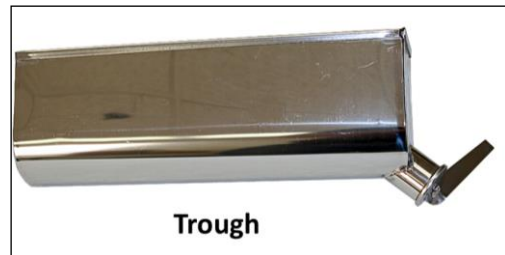
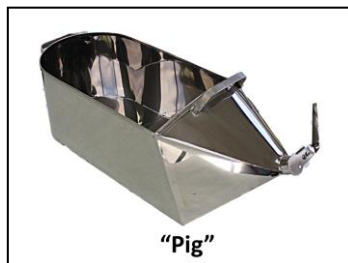

The following information on setup and use of the Sipple Sugar Maker is a general guideline for the proper use. With experience you can adjust the procedure and process to work best for you.

SETUP AND GENERAL USE OF THE SIPPLE SUGAR MAKER

NOTE: The following steps describe how to setup and generally use the Sipple Sugar Maker. For instructions on making the product refer to the sections titled MAKING MAPLE CANDY (page 6) and MAKING MAPLE CREAM (page 8).

1. Prior to using the Sipple Sugar Maker for the first time or after storage, clean the pig, sliding gate, trough and worm with hot water. Thoroughly flush the spouts at the end of the “pig” and the trough.
2. Place the Sipple Sugar Maker base on a stable surface.

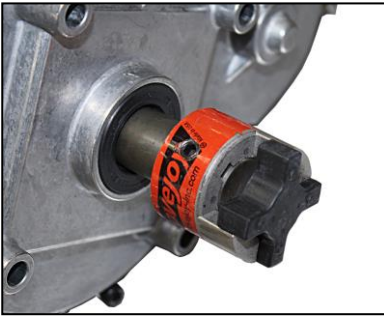

3. Insert the 4-way coupling spider into the coupling on the motor shaft. The fingers of the spider go around the projections of the coupler

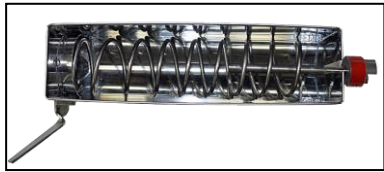

4. Place the worm into the trough so the spiral end of the worm is at the spigot end of the trough. The coupler end will slip into the slot at the other end of the trough.

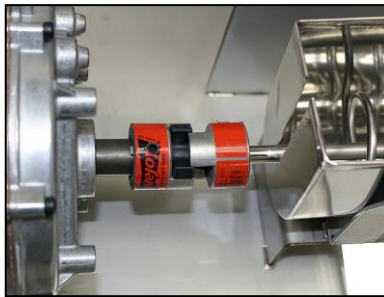

5. Line up the coupler at the end of the worm with the open spots in the spider and slide the trough down into the holders on the base. Slide the trough until the worm spiral end is just touching the spigot end of the trough. There should be no back and forth motion of the coupler joint.



6. Put the slide gate inside the end of the trough where the worm shaft is cut. Slide the gate down until it is seated on the edge of the trough.



7. Support the "pig" platform and slide the locking clip on the "pig" holder hinge up.

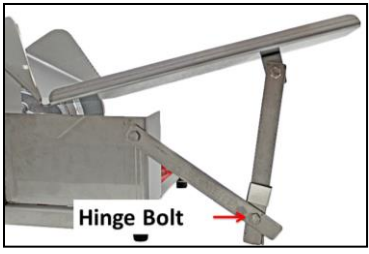

8. Hold the "pig" platform and push the hinge at the bolt carefully away from the machine base. Lower the "pig" platform slowly until the hinge won't move any further.



9. The "pig" is used for boiling and cooling the syrup for the product (see MAKING MAPLE CANDY on page 6 and MAKING MAPLE CREAM on page 8). When the syrup has reached the temperature for the product, the "pig" is placed on the "pig" platform. The "pig" platform has the same approximate shape as the "pig" so align the spout end of the "pig" toward the trough and slide the "pig" against the raised front edges of the platform



10. Slowly raise the platform and "pig" until the hinge locks. NOTE: There will be weight and possibly hot surfaces dependent on the product and quantity being processed.

MAKING MAPLE CANDY

A number of factors influence consistent results in making Maple Candy. Two factors will be considered in this document; temperature and invert sugar. Through experience, research and discussions with fellow makers you will find the best methods for you.

Preparation of Molds

Prior to using molds for the first time or when the molds have not been used for a long period of time, they will need to be pretreated. The method is as follows:

1. Find a pot or pan large enough to hold the mold(s) to be prepared and a boiling solution.
2. Mix a solution of baking soda in the amount of 1/4 pound to a gallon of water. The solution should cover the mold(s).
3. Boil the solution with the mold(s) for 10 to 15 minutes then brush with a semi-stiff brush.
4. Thoroughly rinse the mold(s) with clear cold water.
5. Turn the molds upside down and allow them to dry.
6. Apply a thin coat of food grade glycerine (ex. LEADER EVAPORATOR order #: 13052) to the molds especially the cavities.

To clean the molds after use, immerse in warm water until the sugar material dissolves then rinse with clear water, turn upside down to dry.

Molds should be stored away from direct sunlight or bright lighting.

Always use cooled molds.

If using a new mold and the taste of the candy is bitter, discard the first piece from each cavity. Pieces after the first will be okay.

To make handling easier during use, place the molds on a moveable surface such as a cookie tray.

Selecting the Maple Syrup

It is recommended starting with pure maple syrup with the desired flavor. The syrup should then be tested for invert sugar levels. The maple syrup should have an invert sugar level of 0.5% to 1.5% with a level of 1.0% being best.

Reference the document titled "Invert Sugar Testing Instructions" for a testing process. Low levels of invert sugar can cause the candy to have a coarser texture and the syrup is more likely to start hardening in the pan while cooling. As the invert sugar levels go higher the molded candy takes longer to harden.

Making the Candy

1. Choose a day or an area where the temperature is between 68°F and 72°F with a humidity between 40% and 45%. Do not make candy on rainy days or days with high humidity unless you can control the environment in the work area.
2. Make sure the "pig", trough and worm are clean and free of any sugar residue.
3. You will be filling molds from the spigot at the end of the trough. Move the machine until the spigot is positioned so you can freely move the molds under the spigot. You might find placing the machine on the edge of your work surface will give you enough space to move the molds so each mold cavity can be filled.
4. Place the "pig" on the heat source. Do NOT start heating the "pig" until it contains syrup. Use a heat source able to evenly heat as much of the bottom area of the "pig" at once as possible.
5. Place a pot of water onto a heat source near the "pig". Bring the water to a boil and check the temperature of the boiling water. The use of a digital thermometer is recommended for all temperature measurements (ex. Leader order number: 61005).

6. Close the spout at the end of the “pig” and pour between 1 gallon and 1 ½ gallons syrup into the “pig”.
CAUTION: Do not add more than the 1 ½ gallons to the pig. Overfilling could result in spilling hot liquid from the “pig”.
7. Start the heat source(s) under the “pig” and heat the syrup 32°F to 34°F above the *measured* boiling point of water. If the syrup starts to boil over, control it by adding a single drop of ATMOS 300 defoamer. Do NOT stir the syrup while it is boiling.

NOTE: Watch the heat carefully as it will tend to rise quickly as it reaches the finish temperature.

8. Do NOT stir or move the syrup while it is cooling. Allow the air to flow around all parts of the “pig”. Leave the thermometer in the syrup and cool until it reaches the temperature needed. The following is a guideline of temperature to start stirring with the machine versus the type of candy:

Temperature (°F)	Type of Candy	Notes
>200	Hard	Good for crystal coating
175 to 190	Medium	Can be handled and crystal coated, good hardness for customer
<170	Soft	Harder to handle, good customer appeal

9. When the temperature for stirring is reached, remove the thermometer then carefully transfer the “pig” to the “pig” platform on the Sipple Sugar Maker and slowly raise the platform and “pig” until the locking hinge locks in place. Caution – the syrup solution and the “pig” will be hot.
10. Close the trough spigot then open the “pig” spout until a stream of liquid approximately 1/8” in diameter is pouring into the trough. Bring the level in the trough up to approximately 1/2” then close the spigot.
11. Begin stirring by turning on the motor with the switch located on the cord.
12. Watch the spigot end of the trough for a change in the appearance. The change should take less than 3 minutes. The mix will be ready to draw into the molds when:
 - a. It appears to be lighter in color (light brown)
 - b. Thicker with a cream-like (less transparent) look
 - c. The surface will be less glossy.
13. Drawing into the molds will require experience with working with the machine and the liquid. As you draw off the liquid into the molds open the spigot from the “pig” to allow enough liquid to enter the trough to replace what is being drawn off. You must draw off at a rate preventing the hardening of the material in the trough or the trough spigot. You are working towards having a constant flow of material into the molds and liquid from the “pig” into the trough until the “pig” is empty.
NOTE: Two people working together at this point when you are learning is a good idea.
14. Place the filled molds on cooling racks to cool for at least 3 to 5 minutes then remove the candy from the molds.
15. When the “pig” is empty close the spigot at the end. If the material in the trough has been completed close the spigot at the end of the trough. Shut off the motor.
16. Refer to the Maintenance section for cleaning the machine.

MAKING MAPLE CREAM

Selecting the Maple Syrup

It is recommended starting with pure lighter grade maple syrup with the desired flavor. The syrup should then be tested for invert sugar levels. The maple syrup should have an invert sugar level of 0.5% to 3.0% with a level of 1.5% being best. Correct levels of invert sugar will:

- a. Increase sweetness
- b. Increase the spreadability of creams
- c. Increase the resistance to spoilage due to bacteria and molds

Making the Cream

1. Make sure the “pig”, trough and worm are clean and free of any sugar residue.
2. Place the “pig” on the heat source. Do NOT start heating the “pig” until it contains syrup. Use a heat source able to evenly heat as much of the bottom area of the “pig” at once as possible.
3. Place a pot of water onto a heat source near the “pig”. Bring the water to a boil and check the temperature of the boiling water. The use of a digital thermometer is recommended for all temperature measurements (ex. Leader order number: 61005).
4. Close the spout at the end of the “pig” and pour between 1 gallon and 1 ½ gallons syrup into the “pig”. CAUTION: Do not add more than the 1 ½ gallons to the pig. Overfilling could result in spilling liquid from the “pig” when raising the platform.
5. Start the heat source(s) under the “pig” and heat the syrup 22°F to 24°F above the measured boiling point of water. If the invert sugar of your maple syrup is between 3% and 4% or the weather is rainy or humid then make sure you boil to the upper temperature. If the syrup starts to boil over it can be controlled by adding a single drop of ATMOS 300 defoamer. Do NOT stir the syrup while it is boiling.

NOTE: Watch the heat carefully as it will tend to rise quickly as it reaches the finish temperature.

6. Leave the thermometer in the syrup and rapidly cool until the temperature is 75°F or less. The best temperature for smooth cream is about 50°F. Do NOT stir or move the syrup while it is cooling.
7. When the temperature for stirring is reached, remove the thermometer then carefully transfer the “pig” to the “pig” platform on the Sipple Sugar Maker and slowly raise the platform and “pig” until the locking hinge locks in place.
8. Close the trough spigot then open the “pig” spout until a stream of liquid approximately 1/8 ” in diameter is pouring into the trough. Fill the trough about half full then close the spigot.
9. Begin stirring by turning on the motor with the switch located on the cord.
10. Watch the spigot end of the trough for a change in the appearance. The change could take from a few minutes to 40 minutes. The mix will be ready to draw into the molds when:
 - a. It appears to be lighter in color (light brown to tan)
 - b. Thicker with a cream-like (less transparent) look
 - c. The surface will be less glossy.

NOTE: You can reduce the time required for stirring by adding approximately 1/8 teaspoon of previously made maple cream to the cooled syrup in the trough as you begin stirring.

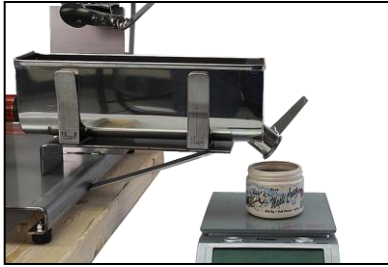

11. To draw off the cream slowly open the spigot end of the trough. As you do so, slightly open the valve in the end of the pig to slowly replace the volume of cream being drawn.

NOTE: Drawing into containers can be easily done with the right setup. An example is shown in the picture on the left. To weigh the cream as you draw it off, set a digital scale under the trough spigot leaving enough room between the top of the scale and the spigot to place the container(s) you will be using. Tare the container on the scale then open the trough spigot and fill the container until the weight is reached.

12. Immediately cover the container and refrigerate.
13. When the “pig” is empty close the spigot at the end. If the material in the trough has been completed close the spigot at the end of the trough. Shut off the motor.
14. Refer to the Maintenance section for cleaning the machine.

MAINTENANCE

AFTER EACH USE

Cleaning The Machine

1. Remove the “pig” from the platform.
2. Slide the trough away from the motor so the couplings can be separated.
3. Remove the slide gate from the end of the trough.
4. Remove the trough with worm from the base.
5. Remove the worm from the trough.
6. Clean the “pig”, trough, worm, and slide gate with hot water. Clean the exposed tip of the thermometer with water. Use water only. Make sure all crystalline sugar residues have been removed.
7. As necessary, wipe down the remainder of the machine to remove residues.

PERIODIC

1. Inspect the 4-way coupling spider for wear. Replace when “arms” are worn or are missing.
2. Inspect the coupling between the worm and the motor. Replace when worn or damaged.

Further Information

Additional information can be obtained:













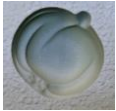
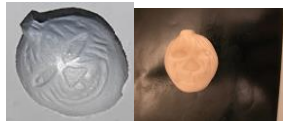



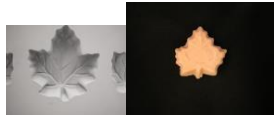

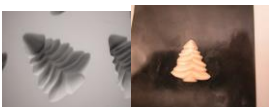
- Searching the internet for the following subjects; Crystal Coating Maple Candy, Shelf Stable Maple Cream, Maple Confections, Maple Cream, Maple Candy, Maple Sugar, etc.
- Books such as the North American Maple Syrup Producers Manual.

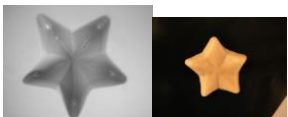

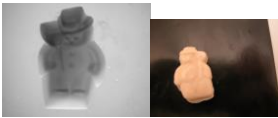







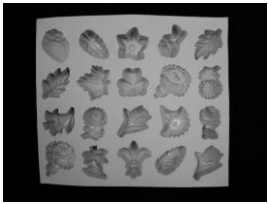

FEEDBACK

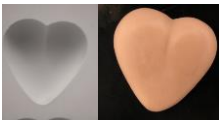

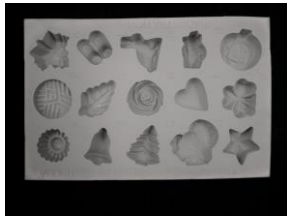
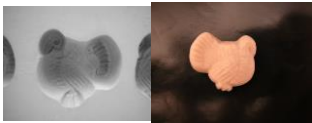





Please use the following e-mail address (feedback@leaderevaporator.com) to suggest improvements or enter comments on this document. Reference the document title in your note. You may also contact LEADER Customer Service.

NOTES:

ATTACHMENT #1: OPERATIONAL SUPPLIES, SPARE AND REPLACEMENT PARTS

ITEM DESCRIPTION	LEADER ORDER #	DESCRIPTION/PHOTO	ITEM DESCRIPTION	LEADER ORDER #	DESCRIPTION/PHOTO
Digital Thermometer	61005		Food Grade Glycerin	13052	
Pumpkin Mold, 20 cavity, 1/3 oz.	581220		Jack-O-Lantern Mold, 20 cavity, 1 oz.	581103	
Maple Leaf Mold, 8 cavity, 2 oz.	581137		Maple Leaf Mold, 12 cavity, 1 oz.	581138	
Maple Leaf Mold, 72 cavity, 1 oz.	581204		Maple Leaf Mold, 20 cavity, 1/3 oz.	581243	
Maple Leaf Mold, 160 cavity, 1/3 oz.	581301		Christmas Tree Mold, 16 cavity, 2 oz.	581144	
Tree Mold, 20 cavity, 1 oz.	581148		Santa Mold, 20 cavity, 1 oz.	581149	
Star Mold, 20 cavity, 1 oz.	581151		Bell Mold, 20 cavity, 1 oz.	581152	
Snowman Mold, 20 cavity, 1 oz.	581473		Snowflake Mold	581477	
Log Cabin Mold, 14 cavity	581163		Bucket Mold, 16 cavity, 2 oz.	581236	
Turtle Mold, 24 cavity, 1/3 oz.	581273		Small Bear Mold	581366	

ITEM DESCRIPTION	LEADER ORDER #	DESCRIPTION/PHOTO	ITEM DESCRIPTION	LEADER ORDER #	DESCRIPTION/PHOTO
Flowers & Leaves Mold, 20 cavity	581465		Moose Head Mold, 6 cavity, 2 oz.	581521	
Frog Mold, 20 cavity, 1/3 oz.	581494		Heart Mold, 15 cavity, 2 oz.	581620	
Wedding Bell Mold, 20 cavity, 1/3 oz.	581518		Heart Mold, 20 cavity	581620	
Variety Mold, 160 Cavity, 1/3 oz.	58V830		Double Heart Mold, 160 cavity, 1/3 oz.	58F42	
Demo Mold, 15 cavity	58DEMO		Turkey Mold, 20 cavity, 1/3 oz.	581104	
Rectangular Box, 2-3/8" X 4-1/4" X 2-1/4"	5820		Flat 1/2 lb. Box 5" X 6" X 1"	5821	
Small 1/4 lb. Box 5" X 4" X 3/4"	5822		Candy Box with Window for 15 1/3 oz. candies	5800 single 5800C case	
Colored Candy Box, 1/2 lb., Gold	5819		Gold Cord with bow, 10"	67034	

ITEM DESCRIPTION	LEADER ORDER #	DESCRIPTION/PHOTO	ITEM DESCRIPTION	LEADER ORDER #	DESCRIPTION/PHOTO
Candy Papers Order numbers as listed 5827 1 oz. 5830 1/3 oz. 5832 1/3 oz. 5834 1 oz. 5837 1 oz. 5831 1/3 oz. 5836 1/3 oz. Packages of 100			Maple Cream Tubs	582106 (½lb.) 582108 1 lb.)	
Plastic Cream Jars	582101 (½ lb.) 582101C (Case of ½ lb. qty.: 150) 582102 (1 lb.) 582102C (Case of 1 lb. qty.: 125)		Glass Cream Jars	582103 (½ lb.) 582103C (Case of ½ lb. – qty: 12) 582104 (1 lb.) 582104C (Case of 1 lb. – qty: 12)	
Polder Digital Scale	61012		North American Maple Syrup Producers Manual	62010 (Hard Cover) 62011 (Soft Cover)	
Making Maple Cream & Candy (DVD)	62017		Homemade Label 100/roll	62071	



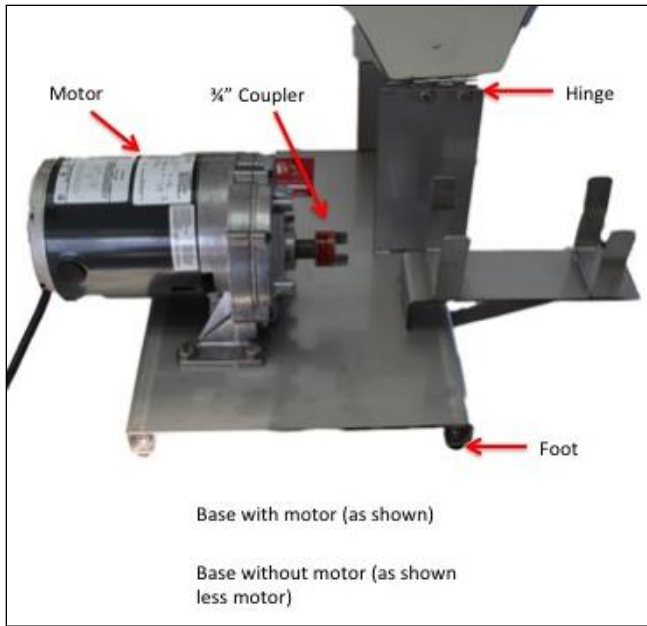



REPLACEMENT PARTS



ITEM DESCRIPTION	LEADER ORDER #
Locking Hinge	5813

ITEM DESCRIPTION	LEADER ORDER #	ITEM DESCRIPTION	LEADER ORDER #
Base with Motor	5802	Base without Motor	5803
Motor	5808	Cord with Switch	55116
3/4" Coupler	760085	Hinge	5812
Rubber Foot	5817		

ADDITIONAL REPLACEMENT PARTS

ITEM DESCRIPTION	LEADER ORDER #	DESCRIPTION/PHOTO	ITEM DESCRIPTION	LEADER ORDER #	DESCRIPTION/PHOTO
Sipple Sugar Maker "Pig"	5804		Sipple Sugar Maker Trough	5806	
Sipple Sugar Maker Slide Gate	5807		Coupling 4-Way Spider	760090	
Sipple Sugar Maker Worm	5805		3/4" Coupler	760086	

Now You Have the Candy – Why not add to your products with Maple Cream and Maple Sugar? The Leader Cream machine is the perfect addition to help you expand your line of profitable products.



Contact a Leader Evaporator Customer Service representative, a Leader Evaporator salesperson or your local dealer for more information.

