



## LEADER EVAPORATOR INFERNO WOOD FIRED ARCH



Leader Evaporator Co., Inc.

49 Jonergin Drive

Swanton, VT 05488

Tel: 802-868-5444

[www.leaderevaporator.com](http://www.leaderevaporator.com)

# TABLE OF CONTENTS

<b>EQUIPMENT DESCRIPTION .....</b>	<b>3</b>
<b>DIAGRAM OF THE INFERNO WOOD FIRED ARCH .....</b>	<b>5</b>
<b>SETUP OF THE INFERNO WOOD FIRED ARCH .....</b>	<b>6</b>
RECEIVING YOUR ARCH: .....	6
SUGAR HOUSE SETUP: .....	6
<i>Foundation For the Arch</i> .....	6
<i>Setting The Arch On The Foundation</i> .....	6
POWERING THE ARCH .....	8
INSULATING THE ARCH: .....	9
<i>General Notes</i> .....	9
<i>Insulating an Arch for a Drop Flue Pan Set</i> .....	14
<i>Insulating a 2X6 Arch for a Raised Flue Pan Set</i> .....	26
<i>Insulating an Arch for a Raised Flue Pan Set 2X8 or Larger</i> .....	34
INSTALL TAPER AND STACK .....	52
<i>Roof Penetration and the Type of Roof Jack:</i> .....	53
<i>Install the Taper and Stack</i> .....	53
THE FIRST BOIL .....	55
<b>OPERATING THE EVAPORATOR .....</b>	<b>55</b>
BLOWER USE .....	57
DAILY SHUTDOWN .....	57
<b>MAINTENANCE .....</b>	<b>58</b>
DAILY .....	58
PERIODIC .....	58
END OF SEASON .....	58
BEGINNING OF SEASON STARTUP .....	58
<b>FEEDBACK .....</b>	<b>58</b>
<b>NOTES .....</b>	<b>58</b>







## EQUIPMENT DESCRIPTION

An INFERNO wood fired arch from LEADER EVAPORATOR is designed to maximize the BTU output of your wood through the use of an airtight front with special domed grates and speed controlled air blower(s).

NOTE: Pictures, sketches and drawings presented in this document are not to scale.

A left feed evaporator is defined, as the regulator float box assembly will be on the left side of the flue pan when standing facing the firing door. A right feed evaporator is defined, as the regulator float box assembly will be on the right side of the flue pan when standing facing the firing door.

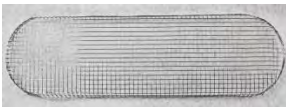
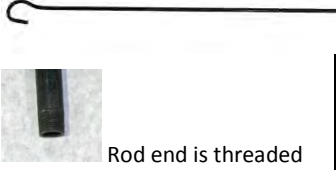
The Leader AMERICAN Evaporator consists of the following parts:

ITEM	LEADER ORDER #	DESCRIPTION / PHOTO	ITEM	LEADER ORDER #	DESCRIPTION / PHOTO
Arch	As Ordered		Grates	Quantity and size for arch ordered – See table below	
Base Taper	To match arch ordered (size and material) – see table below		Smoke stack	Quantity and size to meet specifications for arch ordered – see table below	
Spark Arrester	59202		Flue Brush Rod (8' )	60071 (6') 60072 (8')	 Rod end is threaded to allow mounting of flue brush
Speed Control	68306		One Gang Electrical Box	68309	



## GRATE AND SMOKE STACK INFORMATION

ARCH	Grate Length (inches)	Number of Grates	Stack Taper Height (ft)	Stack Diameter (inches)	Number of Pieces of Stack
2 X 6	18	2	3	10	3
2 X 8	24	2	3	10	4
30 X 8	24	3	3	10	4
30 X 10	24	3	3	10	6

ARCH	Grate Length (inches)	Number of Grates	Stack Taper Height (ft)	Stack Diameter (inches)	Number of Pieces of Stack
3 X 8	24	3	6	12	3
3 X 10	24	3	6	12	5
3 X 12	30	3	6	14	6
40 X 10	24	4	6	14	5
40 X 12	30	4	6	14	6
40 X 14	30	4	6	14	7
4 X 12	30	5	6	18	6
4 X 14	30	5	6	18	7
5 X 12	30	6	6	22	6
5 X 14	30	6	6	22	7
5 X 16	30	6	6	22	9
6 X 14	30	8	6	24	7
6 X 16	30	8	6	24	9

#### OPTIONAL SPARE PARTS, SETUP PARTS AND OPERATIONS EQUIPMENT AND SUPPLIES

ITEM	LEADER ORDER #	DESCRIPTION / PHOTO
Leader Roof Jack		 <p>Peak or Side of Roof Style</p>
Jaco Firestop Plus (10.5 oz tube)	65196	
3000° Full Brick	<a href="#">65003</a>	
Refractory Cement	65001	

ITEM	LEADER ORDER #	DESCRIPTION / PHOTO
Stack Cover		
INSULBOARD 1" X 1'X3' (3 sq. ft)	65000	
3000° Half Brick	<a href="#">65006</a>	

# DIAGRAM OF THE INFERNO WOOD FIRED ARCH

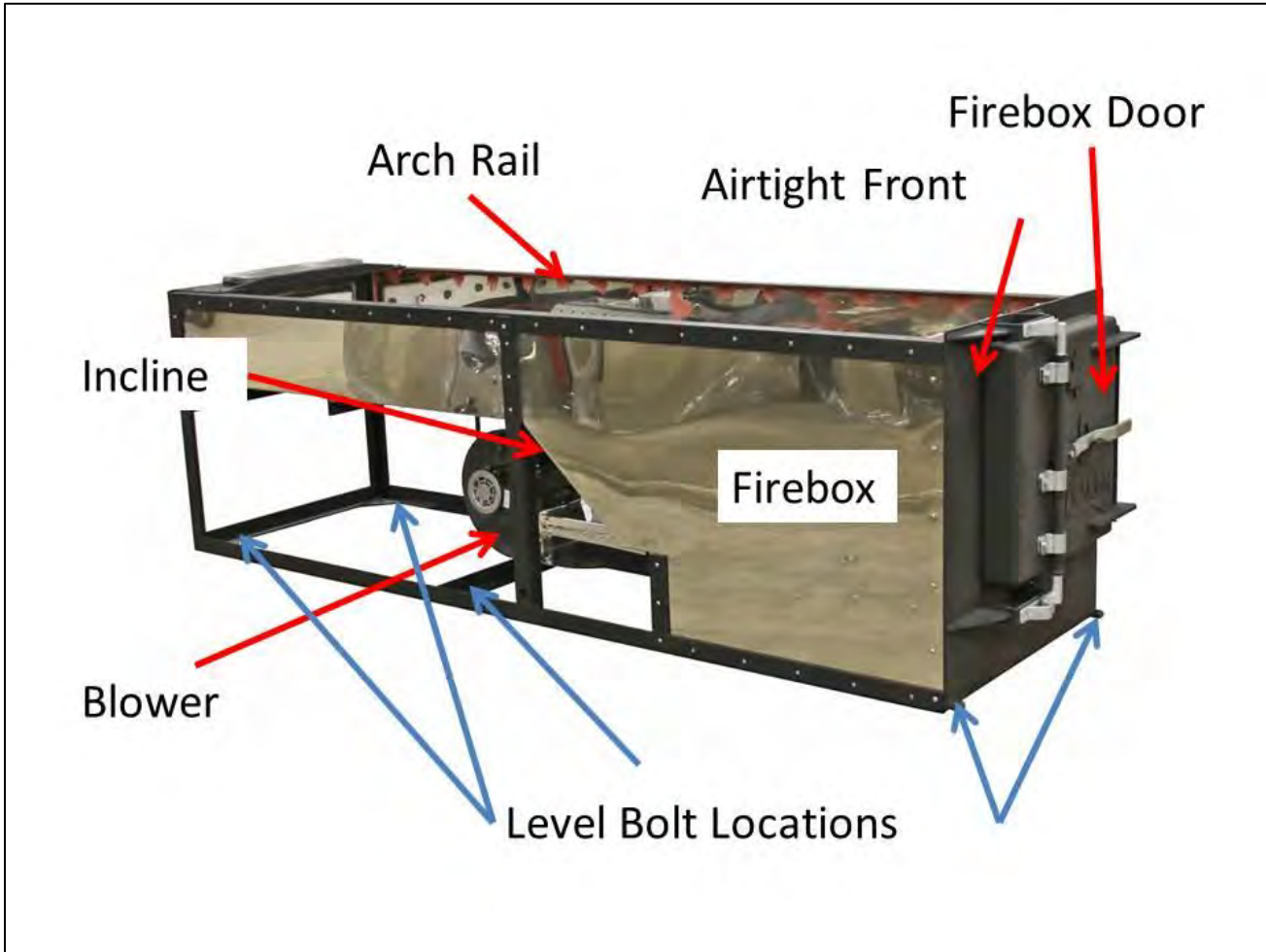

## SETUP OF THE INFERNO WOOD FIRED ARCH

*NOTE: The following information pertaining to setup of an arch is to be considered one suggested method. Installations should meet all applicable governmental regulations and standards.*

### RECEIVING YOUR ARCH:

Upon receipt of the arch, it is recommended the following tasks be performed:

1. Protect all incoming materials from damage and the environment. If possible place the arch at the location where it will be setup (See section titled SUGAR HOUSE SETUP).
2. Unpack all materials and check the received materials against the Equipment Description list provided above.
3. Immediately notify Leader Evaporator or your local dealer if there are questions on the received equipment.

### SUGAR HOUSE SETUP:

Prior to setup of the sugar house, it is suggested future needs be considered. The requirements for the setup of the standard arch may not be adequate if in the future additional or larger equipment will be needed. If assistance is needed in determining possible future requirements please contact Leader Evaporator Sales or your local dealer. The following are *minimum* clearances recommended for around the arch. When determining the clearances, keep in mind any additional items/equipment (ex. packaging supplies, canner, table(s), chairs) and where they will be located in the sugar house:

1. Front of the arch: six (6) feet
  - a. Allows room for firing and cleaning out of ashes
2. Back of the arch: three (3) feet
  - a. Allows for cleaning and removal of the stack
3. Sides of the arch: four (4) feet
  - a. Allows for draw off and movement

### Foundation For the Arch

The following is one suggested method of preparing a foundation for the arch.

1. Standard concrete pad with footings below the frost line should be used under the arch firebox.
2. A layer of 1/8" steel plate at least as wide as the arch and extending 2 feet in front of the arch should be in place to protect wooden floors from hot embers, etc.

### Setting The Arch On The Foundation

1. Place the arch with the firebox centered on the concrete pad. Use a plumb bob to center the collar of the arch to the roof jack – if the roof jack is already installed.
2. Thread the leveling bolts into the leveling bolt locations. Thread until they are approximately ½ threaded. Place a steel shim under each leveling bolt to ease adjustment. The locations of the leveling bolts are listed in the table below.

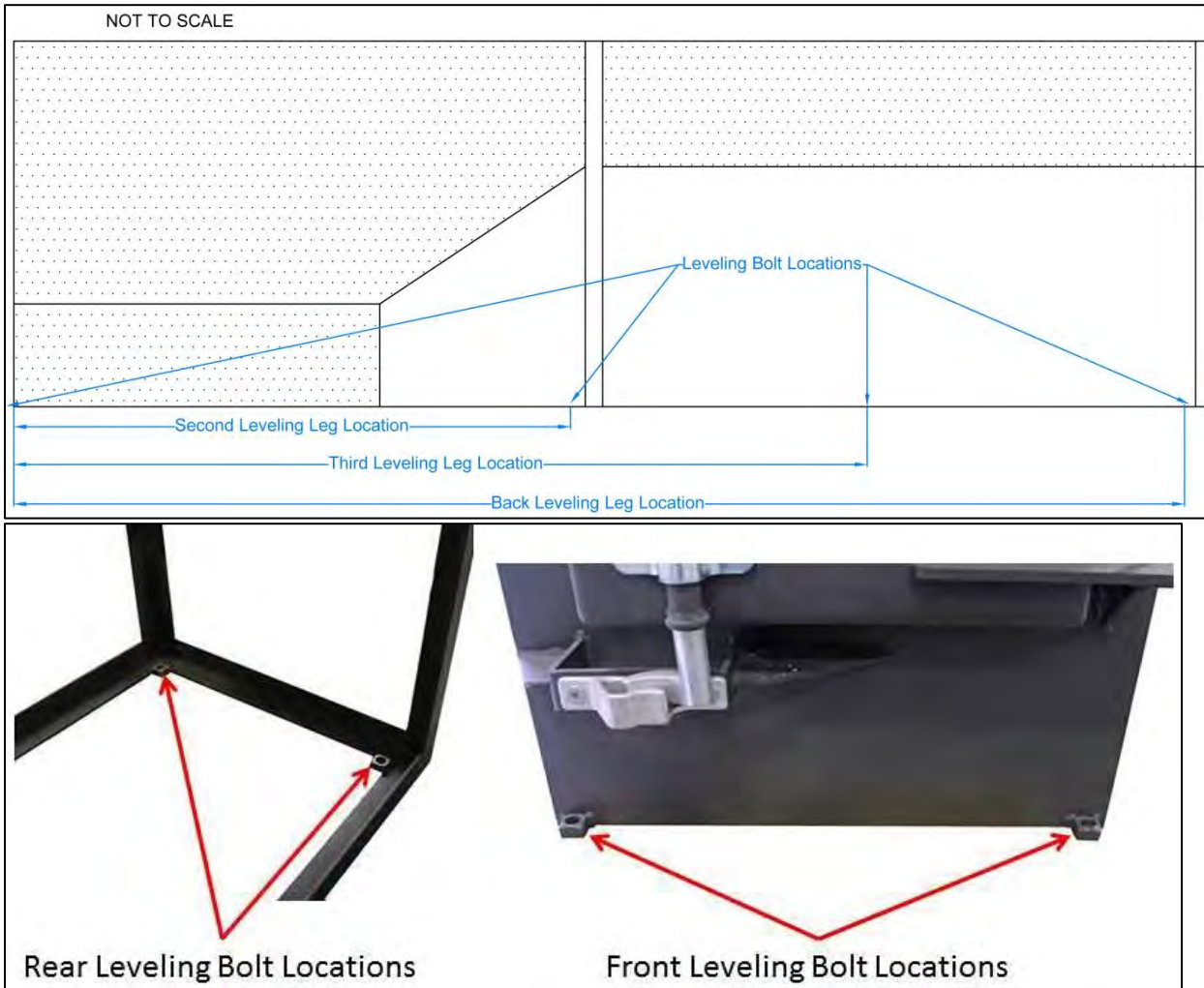

ARCH SIZE	Distance from Front To Second Leveling Leg (inches)	Distance from Front To Third Leveling Leg (inches)	Distance from Front To Back Leveling Leg (inches)
2X6	50.5		78.875
2X8	60		102.875
30X8	60		103.25
30X10	65		127.25
3X8	65		104.75
3X10	65		128.75
3X12	72		152.75
40X10	65		129
40 / 4X12	72		153
40 / 4X14	77	122	177
4X16	87	138	201
5 X14	77	123	181.25
6X14	77	123	181.25
5X16	87	141.25	205.5
6X16	87	141.25	205.5





3. Level the arch on the foundation.
  - a. Place a 4-foot level on the rail of the arch front to back. (The rail is the part where the pans are rested).
  - b. Adjust the level of the arch by raising or lowering the leveling bolts.
  - c. Place the level on the rail of the arch side-to-side.
  - d. Adjust the level of the arch by raising or lowering the corner leveling bolts.
  - e. When the arch is leveled, snug the center leveling bolts, if present, to support of the center of the arch.

## POWERING THE ARCH

The forced air blower for the arch must be wired to a power source. It is recommended the electrical control box be mounted near the front of the arch. It is recommended an additional ON/OFF switch be added to the circuit. Contact a licensed electrician for installation of the speed control and switch circuits.

ARCH WIDTH	BLOWER SIZE (HP)	NUMBER OF BLOWERS	POWER REQUIRED (amps)
2'X6' and 2'X8'	1/6	1	2.3
30"X8' to 40"X14'	1/5	1	3.9
4'	1/2	1	4.9
5' and 6'	1/2	2	9.8



## INSULATING THE ARCH:

### General Notes

- Each of the presented drawings is accompanied by a table of approximate dimensions for cutting and fitting pieces. The ID for each piece to be cut can be cross referenced between the drawing and the table.
- Layout of the insulation of the arch will be dependent on the type of evaporator pan set to be used. Arches are built for dropped flue and raised flue pan sets. The difference will be in the factory and user installation of baffles for the raised flue pan sets. Dropped flue pan sets do not use baffles. Raised flue pan sets have factory baffles installed. With the exception of a 2X6 (or smaller), arches for raised flue pans have 2 factory installed baffles. The diagrams below illustrate the arches:

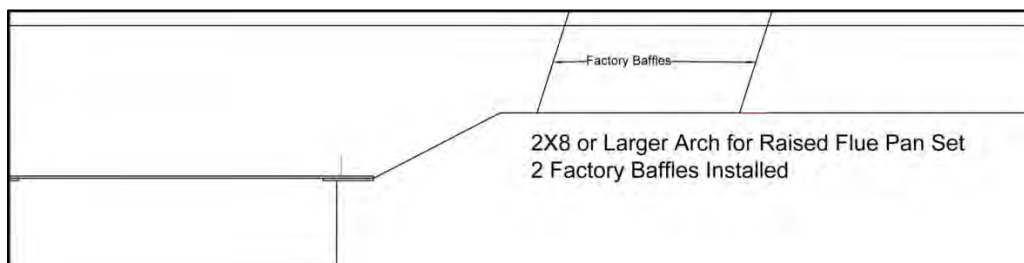
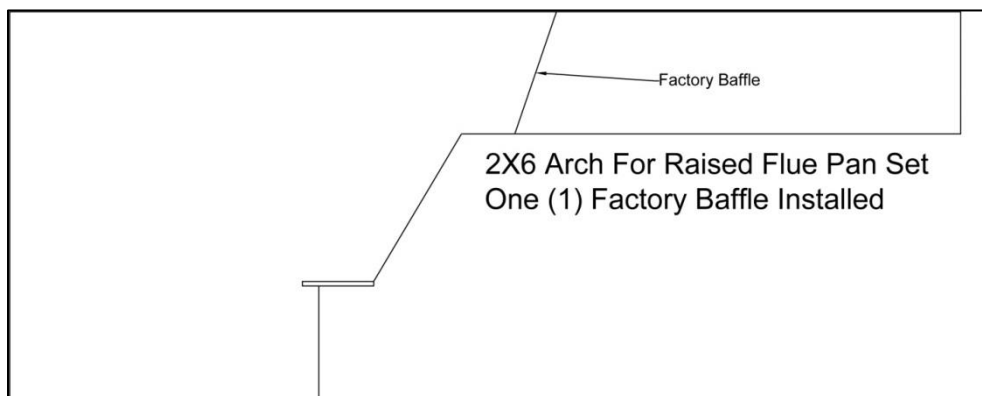
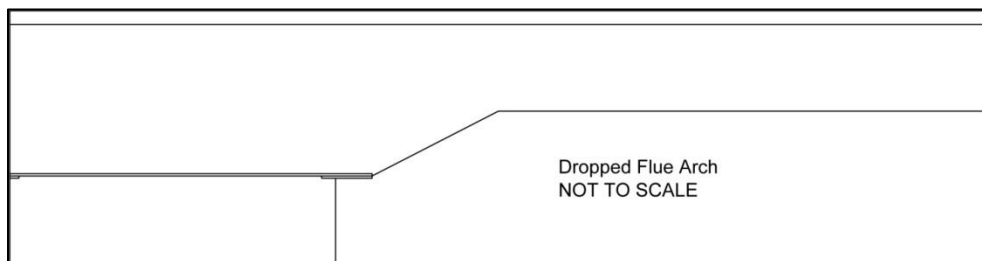

- Obtain the right number of 3000° fire bricks, refractory cement containers and insulation board:

NOTE: The quantities on the table are approximate usages. Actual quantities will vary depending on the actual techniques and layouts employed.

### Dropped Flue

Arch	Half Bricks	Full Bricks	Insulation Board	Refractory Cement (30 lbs. buckets)
2 X 6	48	49	9	2
2 X 8	63	61	12	2
30 X 8	71	80	13	4
30 X 10	88	95	15	5

3X8	73	94	13	4
3X10	91	113	15	5
40 X 10	92	125	16	5
40 X 12	110	146	18	6
40 x 14	127	169	20	7
4 X 12	111	170	18	7
4 X 14	128	196	20	7
5 X 14	133	248	22	9
5 X 16	149	283	25	10
6 X1 4	135	296	23	9
6 X 16	151	338	26	11

### Raised Flue

Arch	Half Bricks	Full Bricks	Insulation Board	Refractory Cement (30 lbs. buckets)	Vermiculite (bags)
2 X 6	55	51	11	2	1
2 X 8	76	59	14	2	1
30 X 8	78	77	14	4	1
30 X 10	99	92	16	5	2
3 X 8	79	101	15	5	2
3 X 10	101	107	17	5	2
40 X 10	102	116	17	5	2
40 X 12	124	124	19	6	3
40 x 14	146	131	21	7	4
4 X 12	125	141	20	7	4
4 X 14	147	148	22	7	5
5 X 14	150	191	24	8	5
5 X 16	170	208	27	9	6
6 X1 4	152	224	26	9	7
6 X 16	171	243	29	10	8

- Begin by fitting the insulation board and bricks in the arch “dry” (no cement). This will allow you to cut and fit all the insulation board and bricks into the arch so the cementing can be done in one continuous application.



NOTE: The use of a wet saw or masonry blade in a circular saw is recommended to cut the bricks where required.

NOTE: The use of a mini hacksaw is suggested for cutting the insulation board.

The following sections are the outline for the preparing and sequencing of the fitting of the insulation board and brick into the arch. Adjustments to shown sizes will be required as the installation proceeds. The rule of “*Measure twice and cut once*” will reduce waste in fitting the pieces. As you go through each of the following pages, cut, “dry fit” then cement the parts into place.

When fitting pieces in the arch there will be bolts and rivets where the pieces are being fit. In order to properly fit for the bolts and rivets either:

- Measure the locations on the sheet and cut out the necessary area for clearance of the rivets/bolts
- OR
- Place the sheet in position and press it against the rivets/bolts in order to mark the rear of the sheet then cut out the marked area to allow for clearance of the rivets/bolts.

NOTE: Insulating sheets at the top of the arch when cut may leave a 3/4" gap between the sheet top and the bottom of the arch rail. If this occurs, after the cement has dried, fill the gap with rail gasket material.

### Cementing of Insulation Board and Bricks

1. Skim coat a layer of refractory cement to the inside arch wall covering the approximate area of the piece of arch board to be mounted. Place the board against the cement.
2. The cement does not need to dry prior to installing the bricks.
3. To install brick, skim coat the rear of the brick and apply a heavier coat to the sides of the brick. Place it into position. As more bricks are added the cement will be forced from the joints. Scrape and smooth off the excess cement. Make sure all openings between the bricks are filled with cement..
4. Allow the cement to dry for 36 hours at room temperature (65°F or higher).

**NOTE: THE LAYOUTS AND DIMENSIONS PRESENTED IN THE FOLLOWING PAGES ARE FOR USE AS GUIDELINES. ALWAYS MEASURE AND "DRY FIT" BOARD AND BRICKS PRIOR TO FINAL PLACEMENT.**

### Bricks

In the drawings standard bricks are labelled as follows:

LABEL	BRICK TYPE
FB	Full Brick (9" X 4.5" X 2.5")
HFB	Half a Full Brick (4.5" X 4.5" X 2.5")
HB	Half Thickness Brick(9" X 4.5" X 1.25")
HHB	Half a Half Thickness Brick (4.5" X 4.5" X 1.25")

The top row of bricks should be cut so they do not prevent the heat from reaching the pans. The bricks will need to be tapered on the top. See the illustration below.

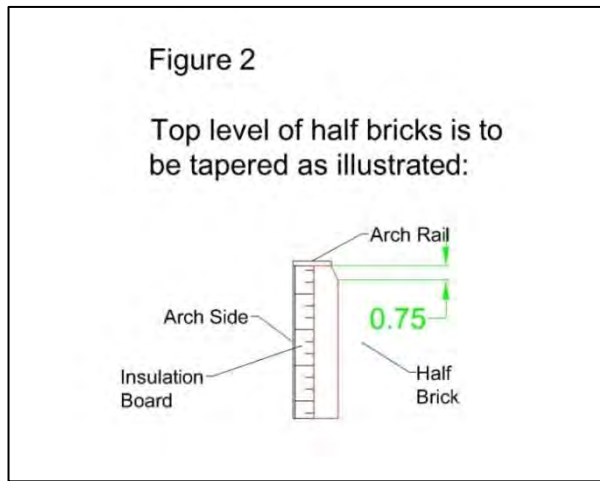
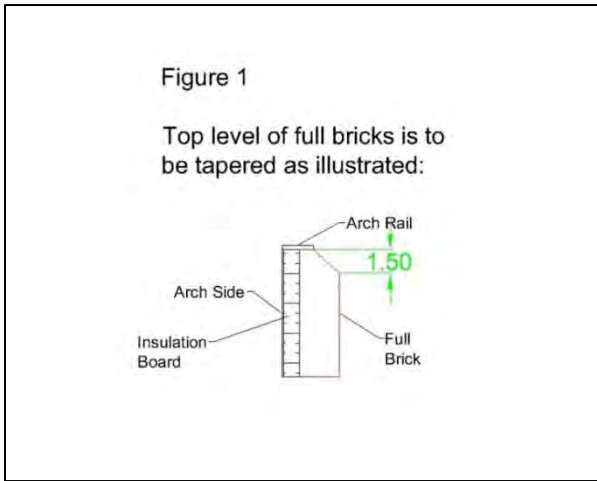

**Considerations For A MAX/COMBO Flue Pan**

In order to properly direct the heat into the flues of a MAX/COMBO flue pan, additional bricking must be added to form baffles at certain locations.

Baffles should be located as indicated in the following table. The measurements are from the front of the stack collar to the front of the brick baffle.

Flue Pan Length (FT)	Qty of Baffles	Location of Baffles (inches in front of stack collar)		
3	1	20		
4	2	20	30	
5	2	20	42	
6	2	20	54	
7	2	20	66	
8	3	20	50	78
9	3	20	56	90
10	3	20	62	102

1. Extra full thickness bricks will need to be ordered to add the baffles. The table below lists the number of bricks needed to add a baffle for each width of arch. Determine the number of baffles to be added and multiply with the number of bricks per baffle in the table

ARCH WIDTH (INCHES)	QUANTITY OF BRICKS PER BAFFLE
24	3
30	4
36	4
40	5
48	6
60	7
72	8

2. Begin by bricking the arch as described for a dropped flue arch.
3. At the locations specified in the table run a row of full thickness bricks across the arch.
  - a. The front of the row of bricks will be at the location specified in the table.
  - b. The bricks should be laid face down on the bricks on the floor of the arch.

### Drain Considerations for a Drop Flue Arch or MAX/COMBO Flue Pan

A drop flue arch is shipped with a flue pan drain hole in the right side of the arch (unless otherwise specified). When installing insulation ensure it is fit to leave the drain hole open.

- Drop flue – center of the drain hole will be 7" down and in line with the front of the collar with a diameter of approximately 2 ¼"
- Max/Combo – 5 ⅛" down and 1" forward of the front of the collar with a diameter of approximately 2 ½"

### Brick Arrangement

In the outlines and examples below, the bricks are shown generally installed in one way. Depending of the width of the arch, it may be less cutting/fitting to have the bricks set 90° to the examples. The areas to which this applies;

- Rear floor – rows **between** the outer rows of bricks
- Incline
- Baffle
- Between the baffles over the vermiculite

## Insulating an Arch for a Drop Flue Pan Set

In the sections below, a generic recommended procedure for insulating an INFERNO arch for a dropped flue pan set is described. Each section is followed by a detailed example showing a 2X8 INFERNO arch.

The following diagram indicates the sections of the arch to be insulated.

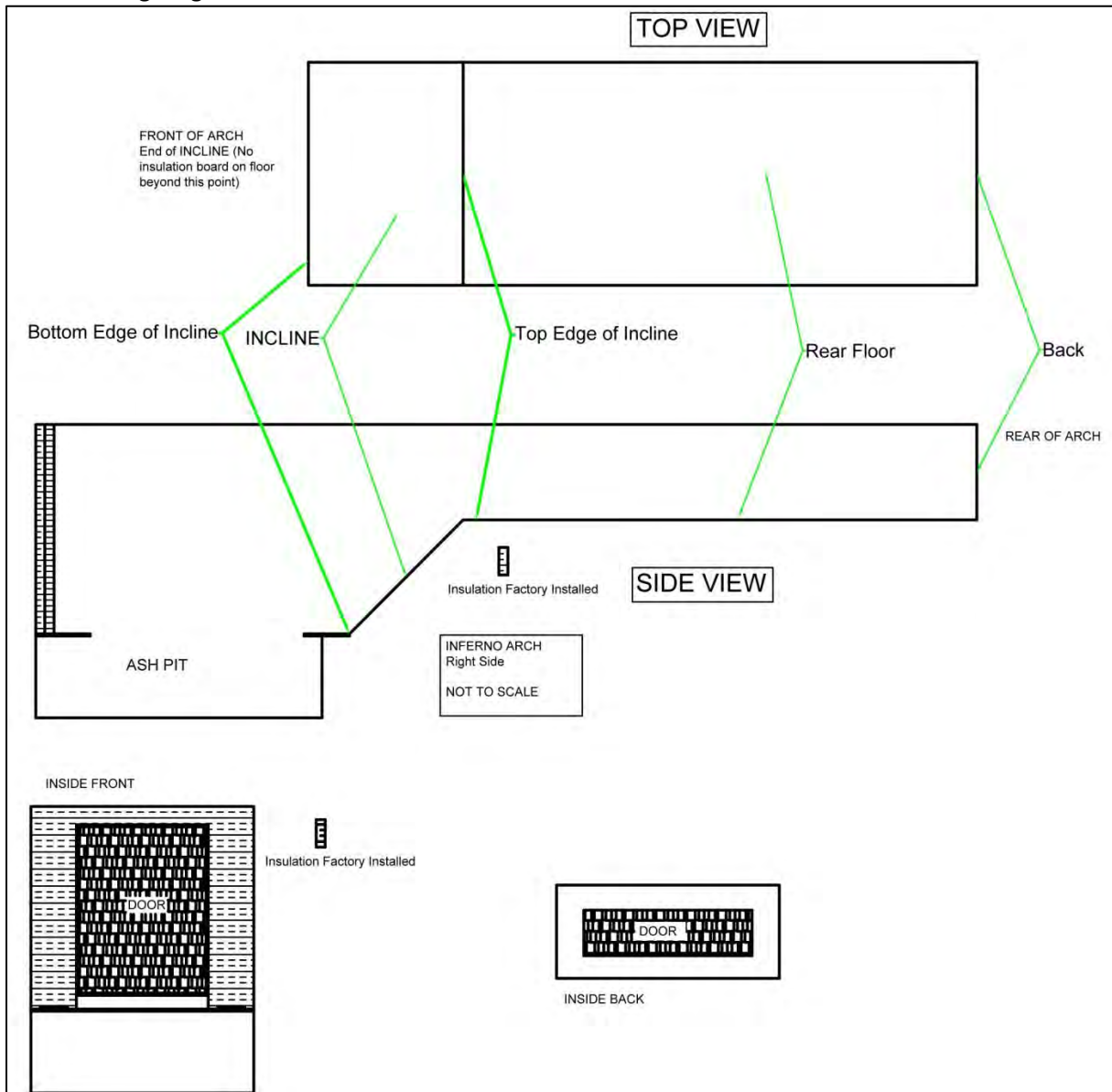

## Insulating the Arch

The order of insulation is as follows:

1. INSULATION BOARD
  - a. Left Side
  - b. Right Side
  - c. Back
  - d. Incline
  - e. Ash Pit Rear

## 2. BRICKING

- a. Floor behind incline
- b. Left Side
- c. Right Side
- d. Grate area
  - i. Front grate shelf
  - ii. Install grates
  - iii. Rear grate shelf
- e. Incline

### Insulation Board

#### *Left and Right Side – General Outline*

Right side shown – mirror for left side.

#### *Step 1*

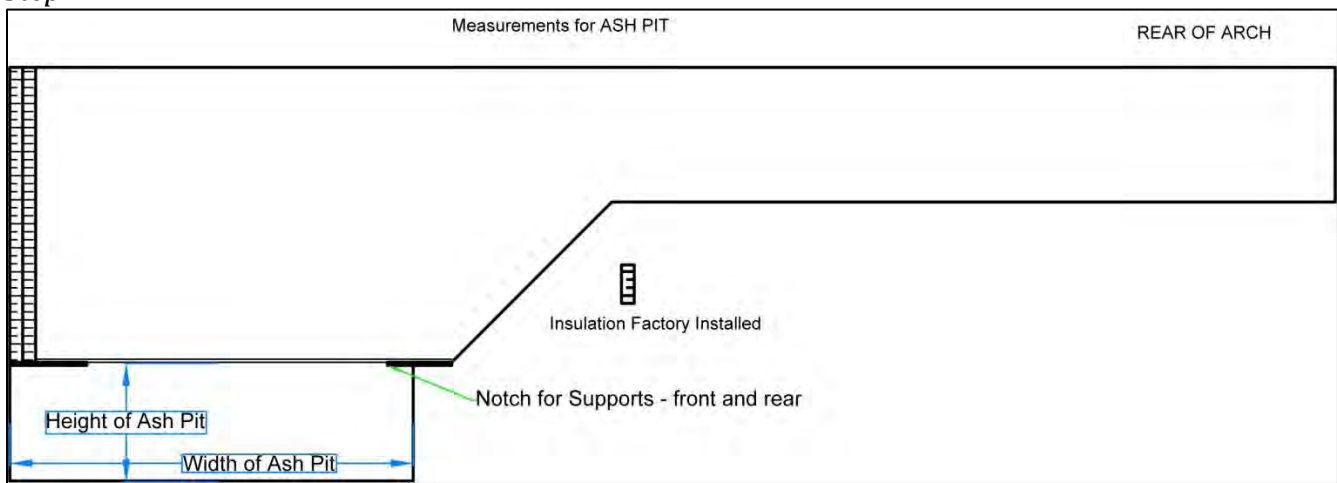

1. Measure the distance from the bottom of the ash pit in the arch to the underside of the band iron going between the grate support shelves. (height of the ash pit)
2. Measure the distance from the front of the ash pit to the rear of the ash pit. (width of the ash pit)
3. Using the measurements, determine the best way to use the pieces of insulation board and cut them to fit. Notch out the area for the grate support shelves.
4. Double check the fit then cement the pieces into place.



### Step 2

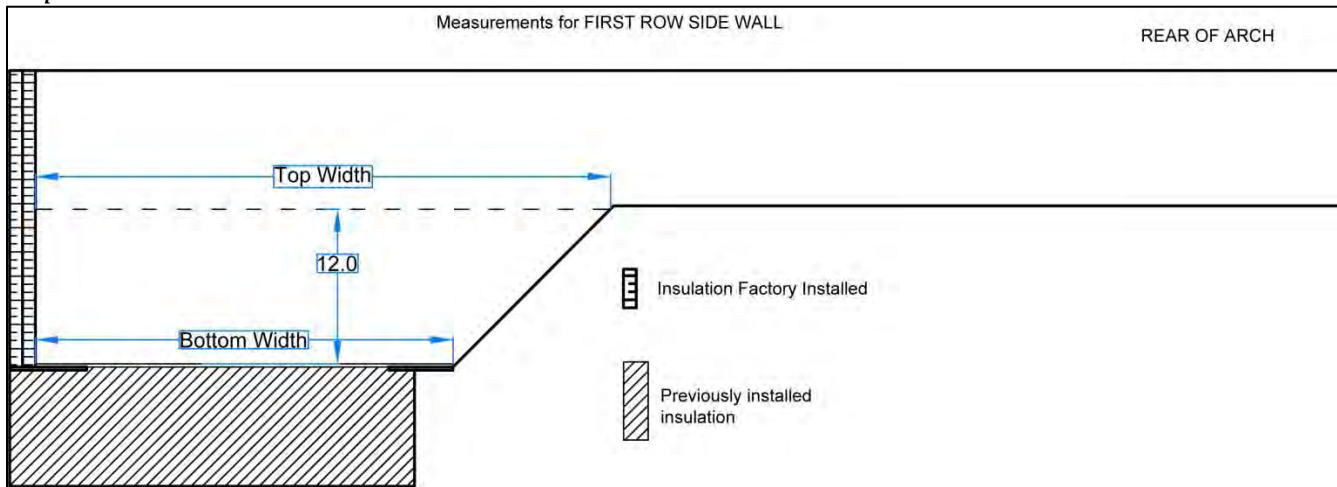

1. Measure the distance from the insulation in the front of the arch to the bottom of the incline (bottom width). If the bottom width is less than 36" then board will need to be cut to fit the incline. If the measurement exceeds 36" place a full insulation board in place and determine the distance from the rear of the insulation board to the incline at the top and bottom.
2. Using the measurements, determine the best way to use the pieces of insulation board and cut them to fit.
3. Double check the fit and cement the pieces into place.

### Step 3

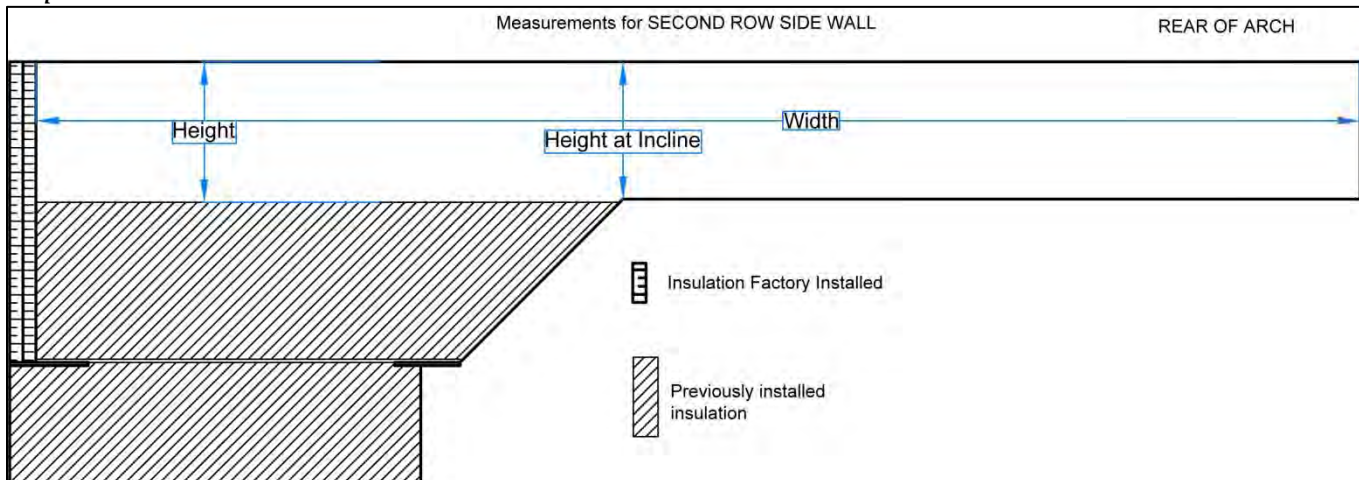

1. Measure the distance between the top of the second row of insulation board and the bottom of the arch rail. Measure the distance between the top of the incline and under the arch rail. If the heights are not the same, notch the board at the incline to have the heights meet.
2. Using the measurements, determine the number of and best layout for pieces of insulation to cover the area. Cut the pieces to fit.
3. Double check the fit and cement the pieces into place.

NOTE: If a dropped flue or Max/Combo flue pan is to be used, a drain hole will need to be cut into the insulation board on the right side. The location and size for the drain hole is as follows:

- Drop flue – center of the drain hole will be 7" down and in line with the front of the collar with a diameter of approximately 2 ¼"
- Max/Combo – 5 ⅝" down and 1" forward of the front of the collar with a diameter of approximately 2 ½"

Completed Side

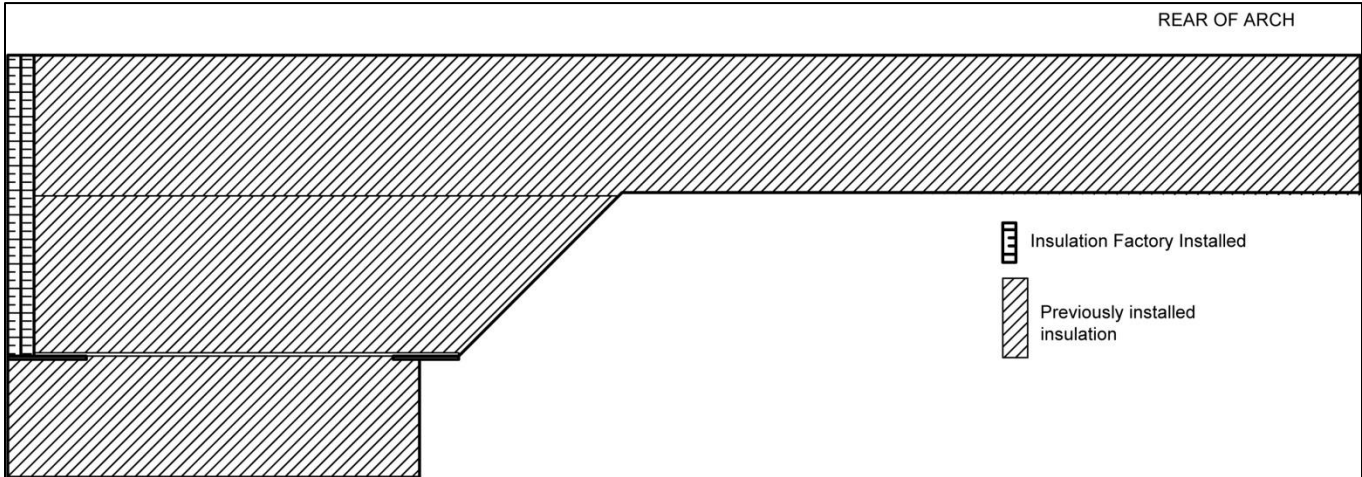

Left and Right Side - Detailed 2X8 Example

Right Side shown. Mirror for Left side without the flue pan drain cutout.

2X8 INFERNO ARCH  
Right Side  
Insulation Board Layout  
NOT TO SCALE

Insulation Factory Installed

A drop flue and Max/Combo flue pan require a drain hole cutout. The center locations and sizes are:

- Drop Flue - 7" down in line with the front of the collar with a diameter of approximately 2¼"
- Max/Combo - 5⅝" down and 1" forward of the collar with a diameter of approximately 2½"

R3

R2

R1

R5

R4

R6

Flue Pan Drain Cutout

RIGHT SIDE INSULATION BOARD			
ID	Length	Width	NOTES
R1	31.500"	9.250"	Notch to fit between grate shelves
R2	Top:36.000" Bottom: 32.5"	12.000"	Taper Cut starts 8.500" from top
R3	36.000"	11.000"	
R4	Top: 9" Bottom: 0"	9.000"	
R5	36.000"	10.500"	
R6	29.500"	10.500"	See note on Flue Pan Drain Cutout

INFERNO Wood Fired Arch

October 2018

Page:

17

*Back - General Outline*

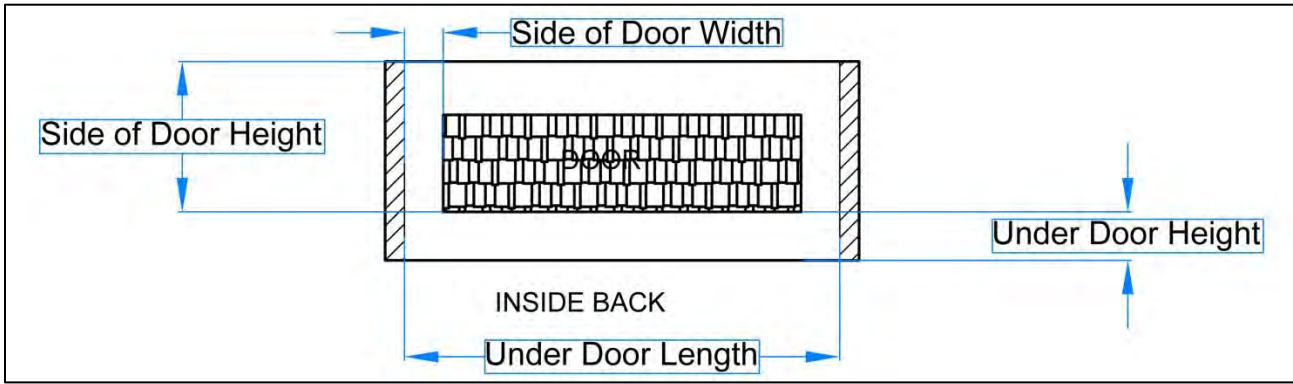

1. Measure between the insulation board installed on each side of the arch. (Under Door Length)
2. Measure from the angle iron at the bottom of the back to the bottom of the door. (Under Door Width)
3. Cut a piece of insulation board to fit in the area.
4. Double check the fit then cement into place.
5. Measure the distance between the door and the insulation on one side of the arch. (Side of Door Width)
6. Measure the distance from the top of the insulation board installed below the door and the bottom of the arch rail. (Side of Door Height)
7. Using the measurements, determine the best way to use the insulation board and cut them to fit. You will need two side pieces.
8. Double check the fit and cement the pieces into place.

*Back - Detailed 2X8 Example*

2X8 INFERNO Arch  
BACK  
Insulation Board Layout  
NOT TO SCALE



Insulation Board  
Previously Installed

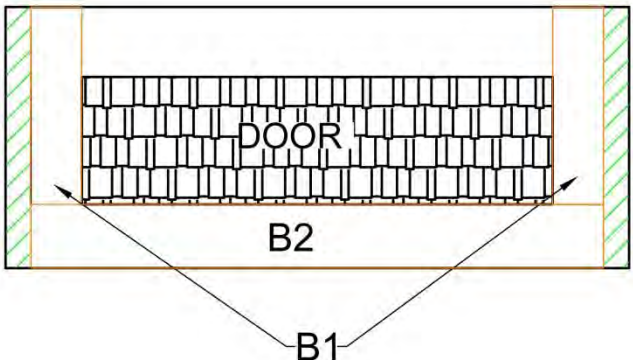

BACK INSULATION BOARD		
ID	Length	Width
B1	7.750"	2.000"
B2	22.500"	2.500"



## Incline – General Outline

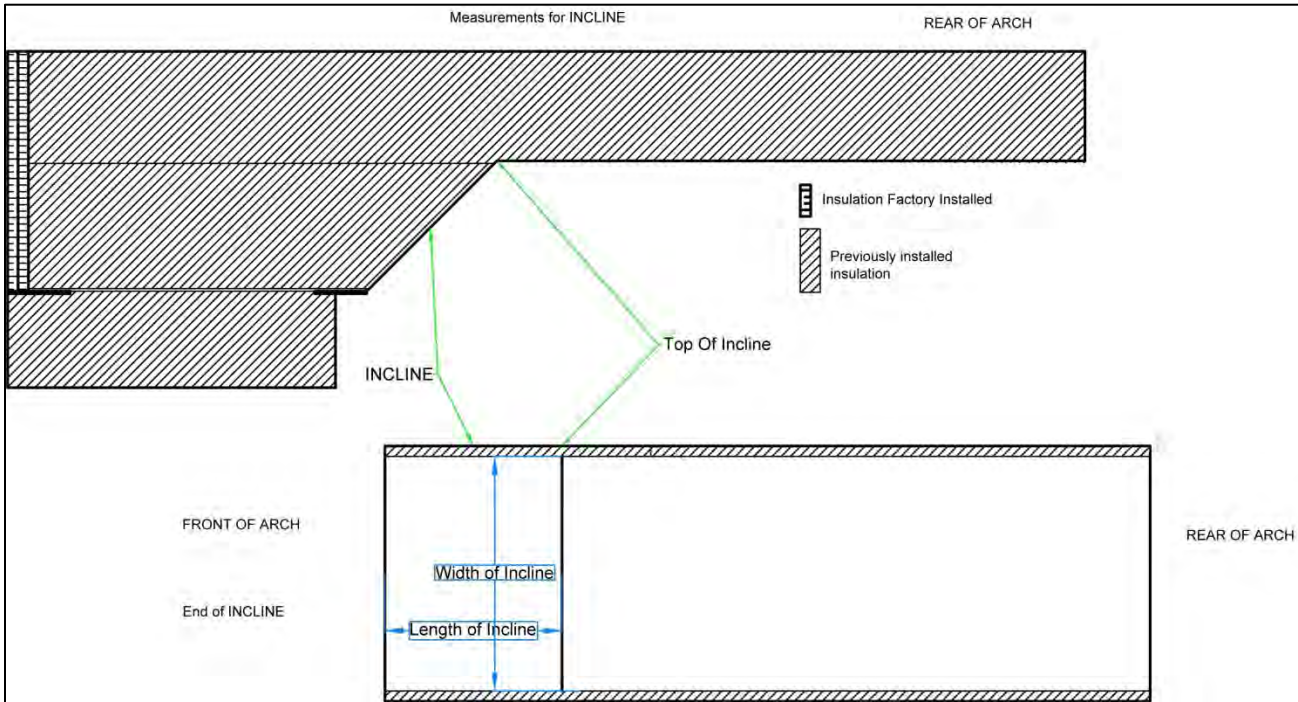

1. Measure the distance between the insulation on each arch side at the incline. (Width of Incline)
2. Measure the distance from the bottom of the incline to the top of the incline where it meets the rear floor. (Length of the Incline)
3. Using the measurements, determine the number of and the best way to layout the piece(s) of insulation board to cover the area. Cut the pieces to fit.
4. Double check the fit and cement the piece(s) into place.

## Incline – Detailed 2X8 Example

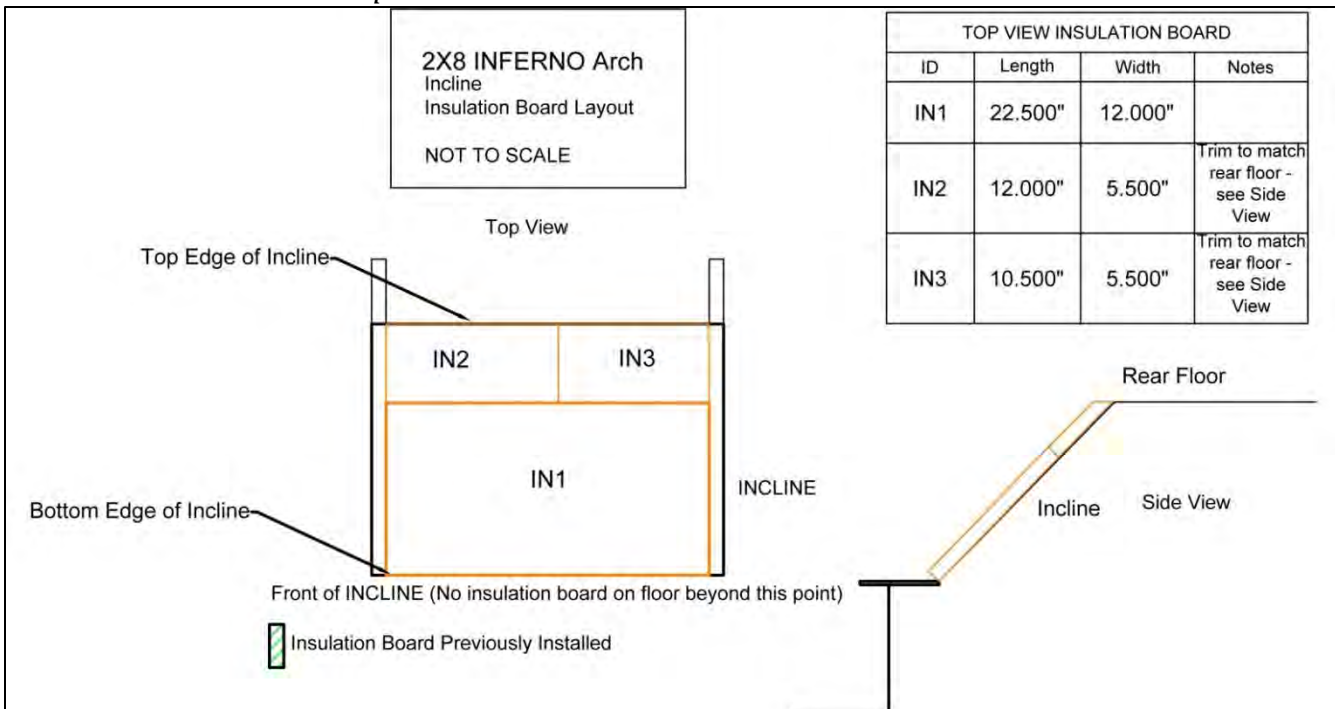

### Ash Pit Rear – General Outline

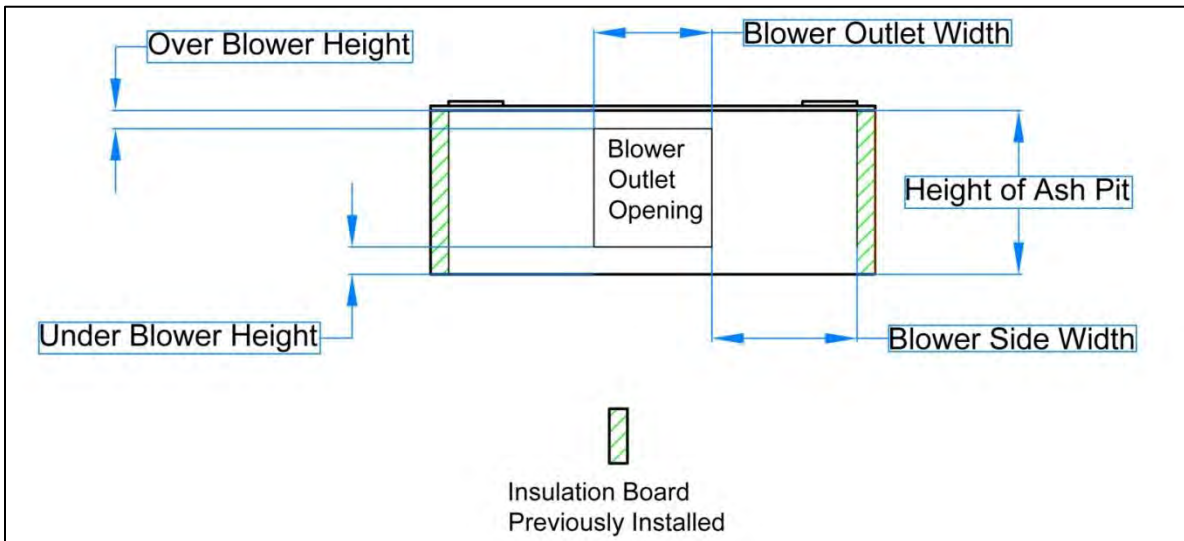

1. Measure from the edge of the blower opening to the insulation on the side of the arch. (Blower Side Width)
2. Measure the distance between the angle iron on the bottom of the front to the underside of the front grate shelf. (Height of Ash Pit)
3. Measure the distance between the bottom of the arch front and the bottom of the blower outlet. (Under Blower Height)
4. Measure the Distance between the top of the blower outlet and the bottom of the grate shelf. (Over Blower Height)
5. Measure the width of the blower opening. (Blower Outlet Width)
6. Using the measurements, determine the number of and the best way to layout the piece(s) of insulation board to cover the area. Cut the pieces to fit.
7. Double check the fit then cement the pieces into place.

NOTE: INFERNO arches 5 foot and 6 foot in width have 2 blowers and outlets. The same general fitting process can be used with the exceptions:

- The Blower Side Width will be the distance from the outside of each blower outlet
- A piece of insulation board will need to be fit between the insides of the two blower outlets.

### Ash Pit Rear – Detailed 2X8 Example

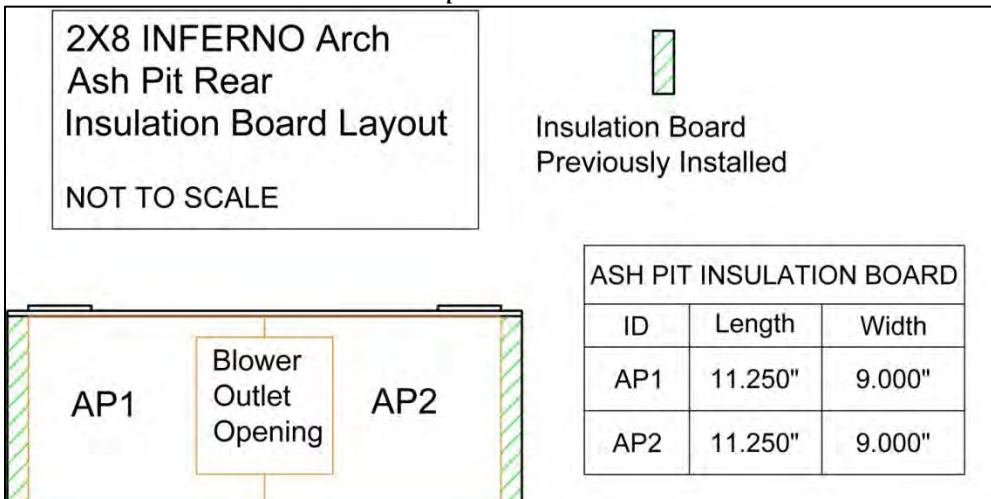

**Bricking**

***Rear Floor Behind the Incline – General Outline***

1. Begin by placing a row of full thickness bricks lengthwise against the rear of the arch.
2. Along each side of the arch, run a row of half thickness bricks parallel to the side of the arch.
3. Trim the last brick over the incline so it is even with the insulation board on the incline.
4. Between the rows of half bricks, run rows of full bricks up to the last full length brick before the incline.
5. Complete the rows of full thickness bricks to the incline trimming so they are even with the insulation board on the incline.
6. Double check the fit and cement the bricks into place.

***Rear Floor Behind the Incline – Detailed 2X8 Example***

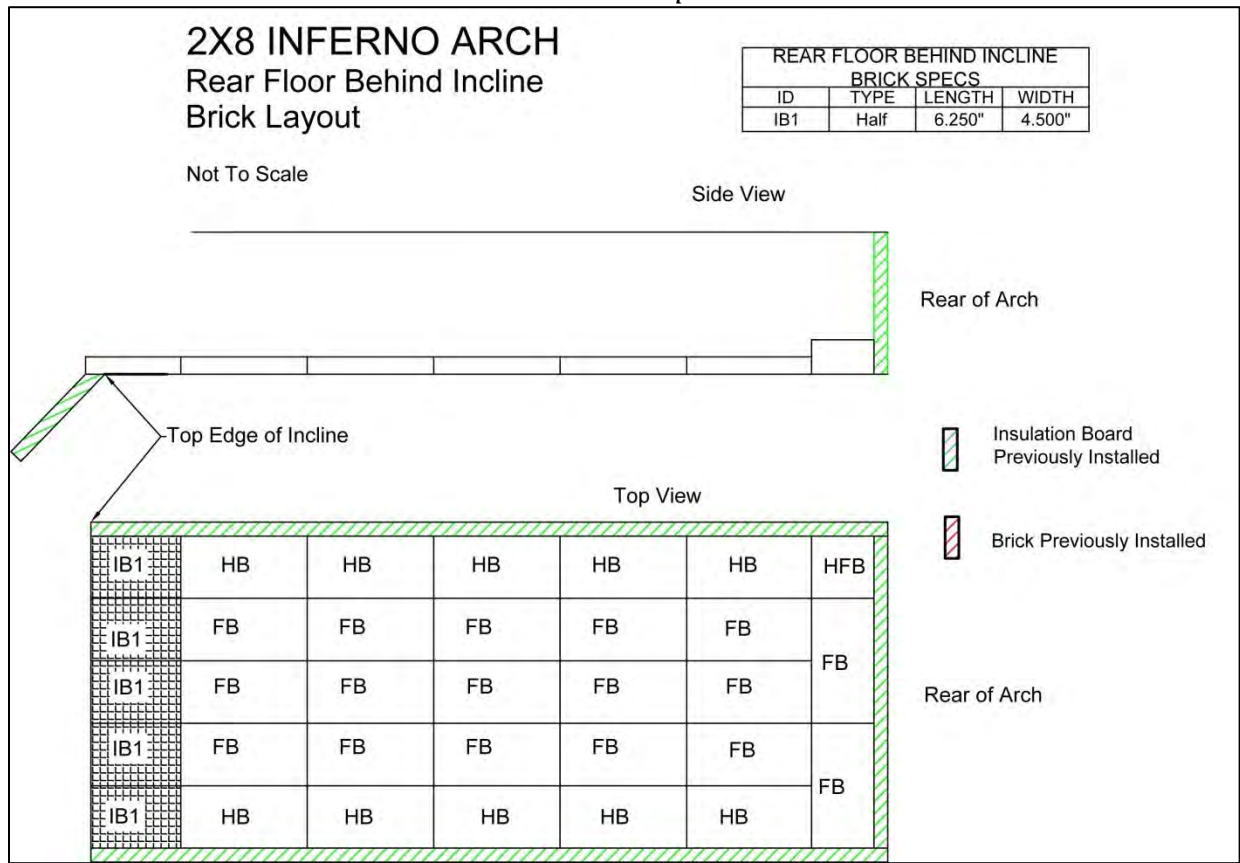

***Left and Right Side – General Outline***

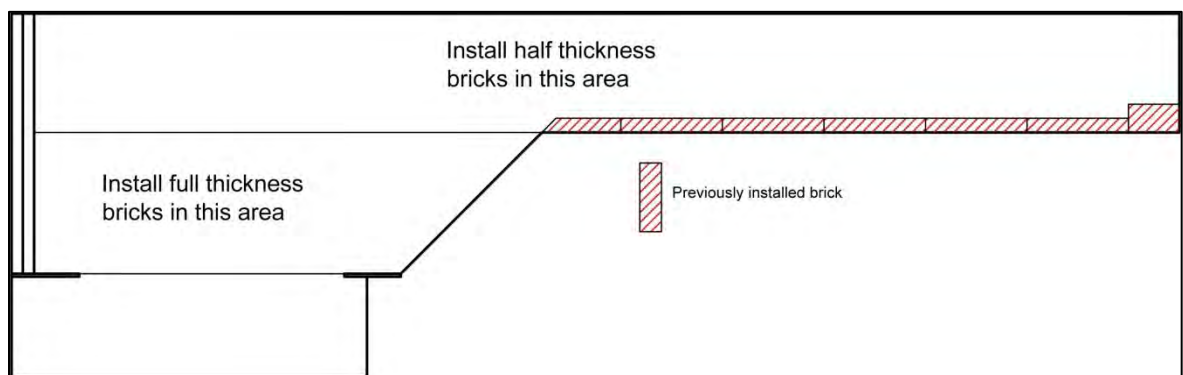

The first three rows over the band iron grate spacers will be horizontal rows of full thickness brick. This will be followed by a row of vertically oriented half thickness bricks. Using half thickness bricks in this manner maximizes the area of the syrup pan being heated.

1. Place a full thickness brick with the short end against the insulation of the door and the brick face against the insulation on the side of the arch.
2. Continue placing the bricks end to end until the insulation board on the front of the incline is reached. The last brick against the incline will need to be trimmed to follow the angle of the incline.
3. Start the next row of bricks with a full thickness brick cut in half ( $4\frac{1}{2}'' \times 4\frac{1}{2}''$ ).
4. Continue placing the bricks end to end until the insulation board on the front of the incline is reached. The last brick against the incline will need to be trimmed to follow the angle of the incline.
5. Start the third row of bricks with a full brick.
6. Continue placing the bricks end to end until the insulation board on the front of the incline is reached. The last brick against the incline will need to be trimmed to follow the angle of the incline and even with the top edge of the incline, if necessary.
7. Double check the fit and cement the bricks into place.
8. Begin the top row of bricks by placing a half thickness brick on the top of the third row of bricks with the long edge against the insulation in the front of the arch and the brick face against the insulation on the side of the arch.
9. Continue placing bricks until the rear of the arch is reached. There may be a difference in the length of the brick needed after the top of the incline is reached. The side bricks placed after the top of the incline will rest on the bricks on the rear floor. Additionally it will be necessary to fit the last brick(s) over the full brick on the floor at the rear of the arch.
10. Double check the fit and cement the bricks into place.
11. Fill any spaces between the top brick and the underside of the arch rail with rail gasket.

**Left and Right Side – Detailed 2X8 Example**

Right side shown. Mirror for left side without the flue pan drain hole

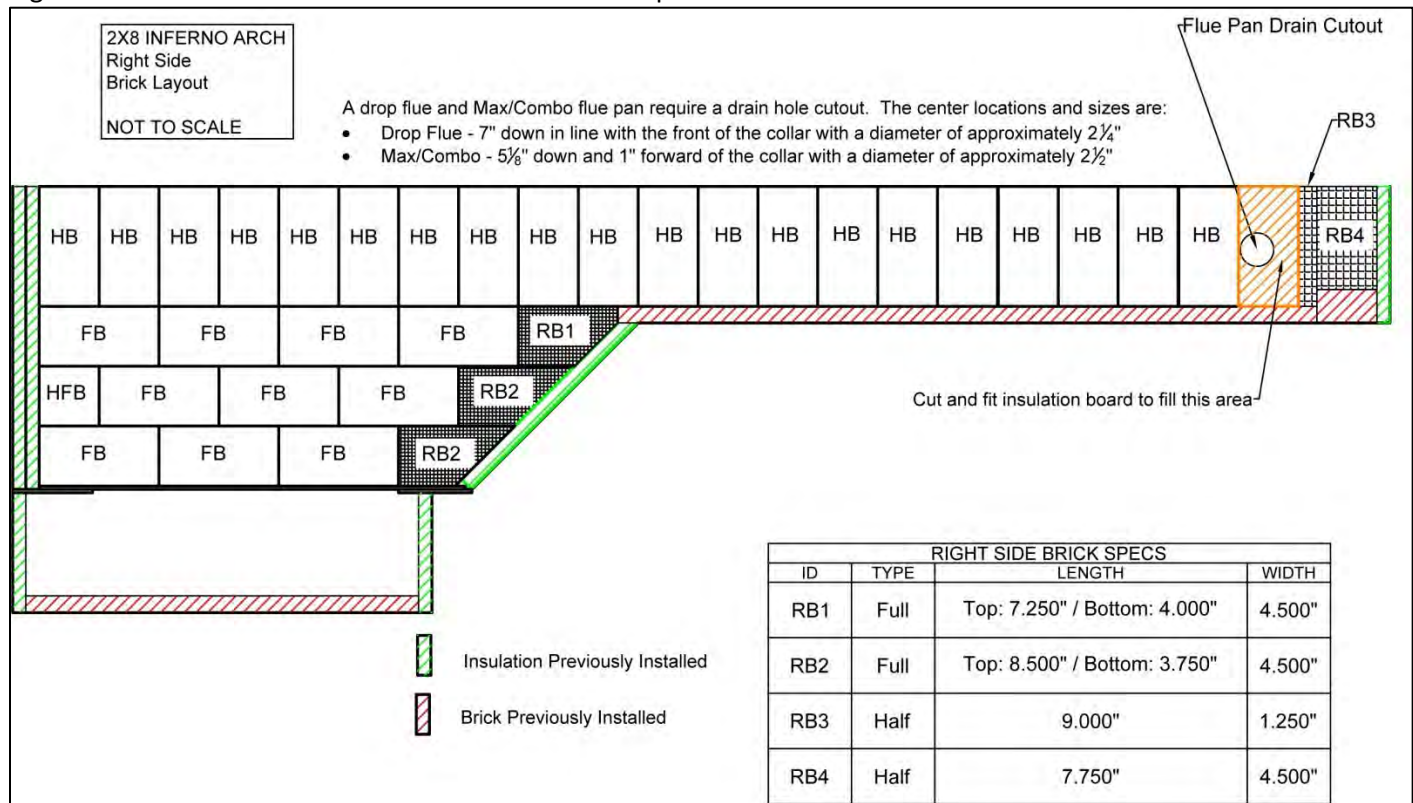



## Grate Area

### Front Grate Shelf – General Outline

The area to be covered will be;

- From the insulation of the front to 1" from the edge of the grate shelf.
- From the insulation on one side of the arch to the other

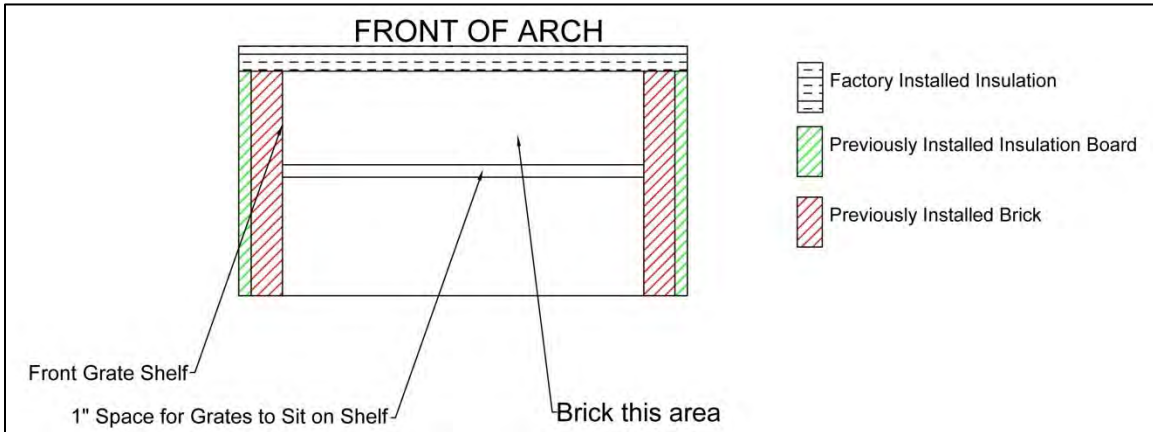

1. Cover the area to be bricked with full thickness bricks placed face down against the grate shelf.
2. Fit the bricks, double check the fit then cement the bricks into place.

### Front Grate Shelf – Detailed 2X8 Example

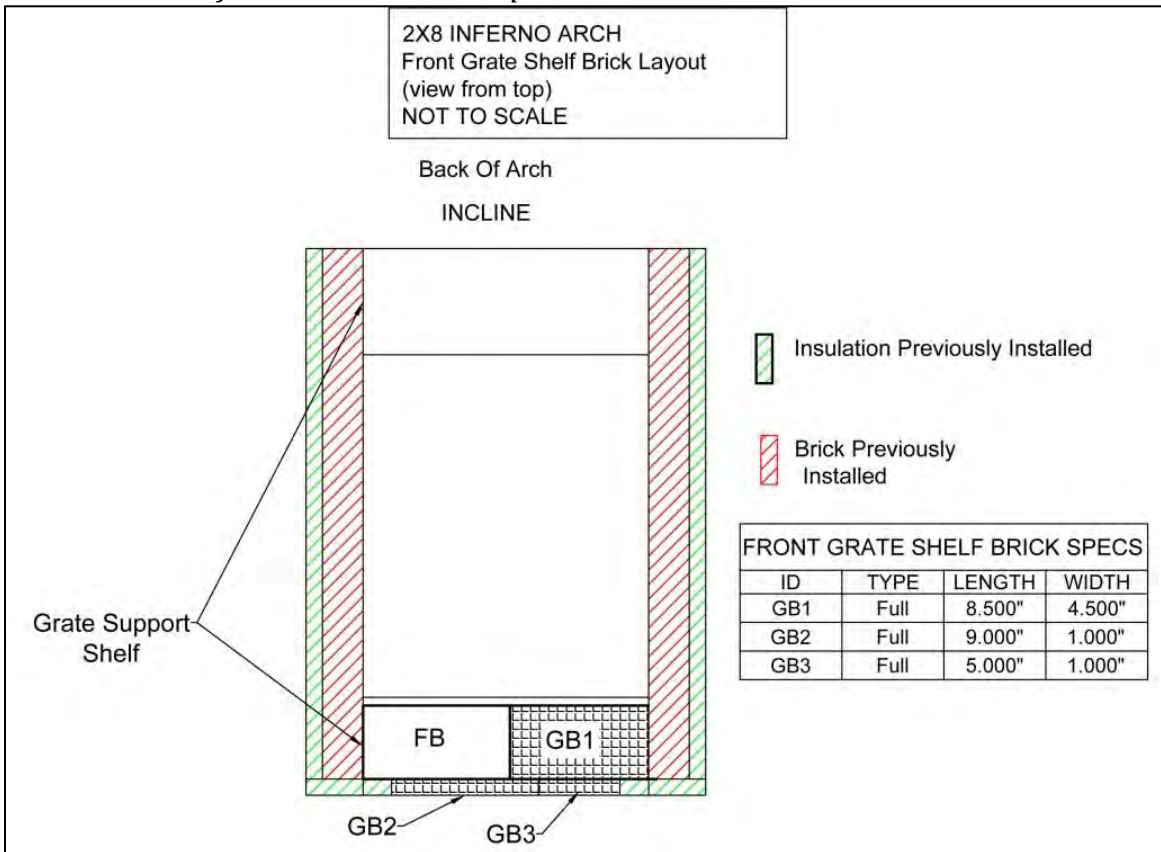

## Install the Grates

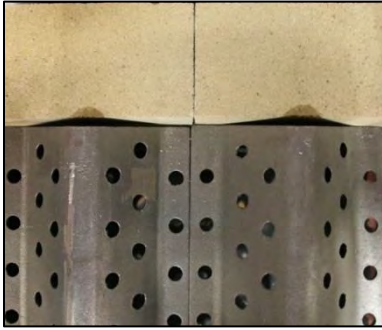

Place the two arch grates into the arch so the front of the grates are against the stainless steel front floor plate of the arch. The grates fit between the band irons at the sides of the arch and will rest on the front and back support shelf by approximately 1" each.

NOTE: To obtain the best fit between the side band irons it may be necessary to flip the grates end for end as the widths of the grates will vary slightly along the length.

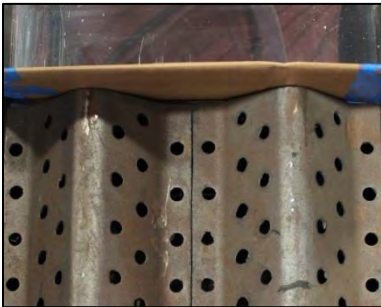

Obtain a piece of "C flute" cardboard (most common type of cardboard). Fold it into thirds along the length and tape with a non-plastic tape (ex. masking tape). Place it behind the grates toward the rear of the arch. The cardboard will provide the spacing needed to remove the grates after the insulating materials have been fit in place. The cardboard can be left in place as it will be consumed during the first firing of the arch.

### PROPER ORIENTATION OF GRATES

Grates should be installed so the flat side is down on the supports.

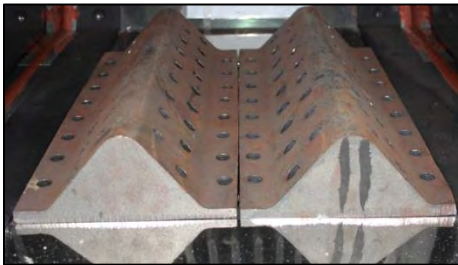

## Rear Grate Shelf – General Outline

The area to be covered will be;

- From the board insulation on the incline tight to the cardboard.
- From the insulation on one side of the arch to the other

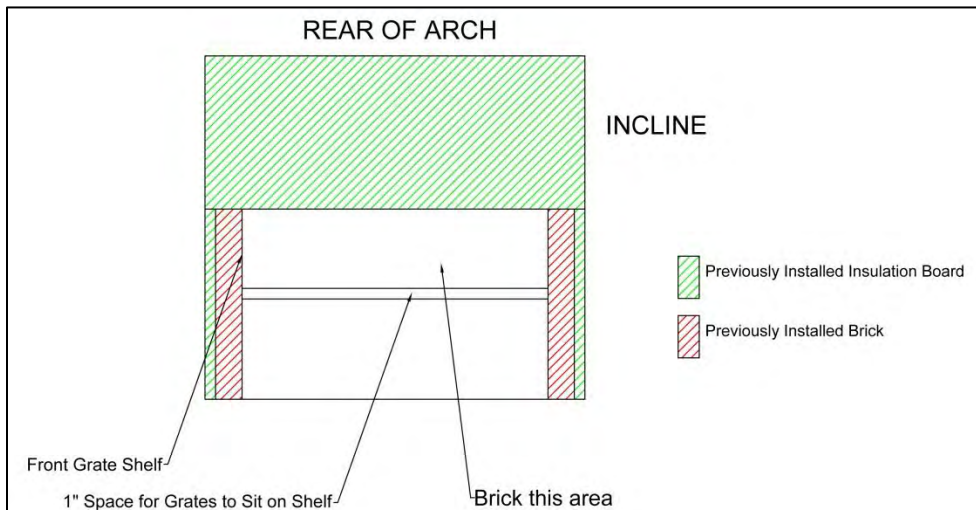

1. Cover the area to be bricked with full thickness bricks placed face down against the grate shelf. Generally the best arrangement will be to place the bricks parallel to the edge of the grate shelf.
2. Fit the bricks, double check the fit then cement the bricks into place.

*Rear Grate Shelf – Detailed 2X8 Example*

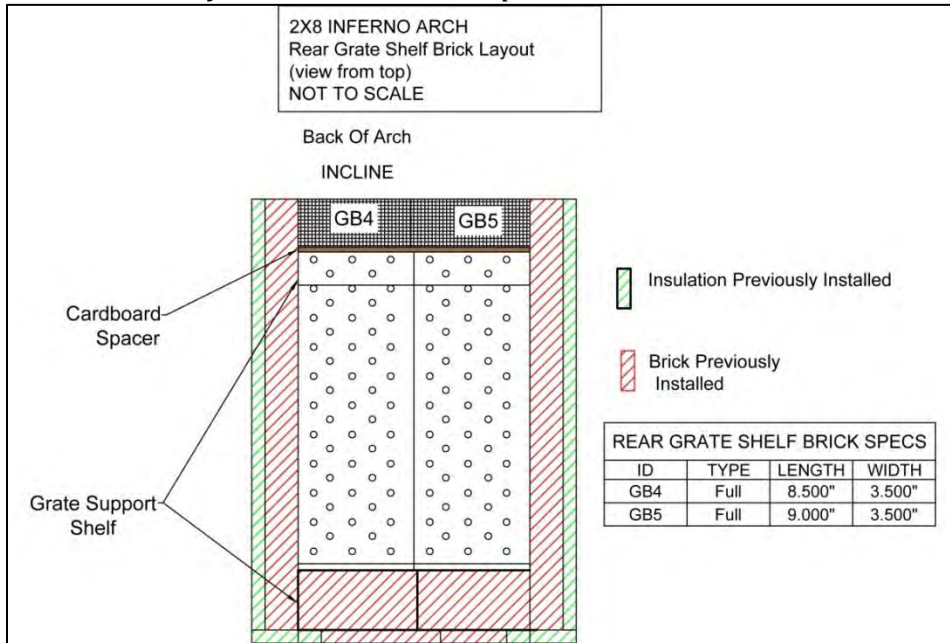

*Incline – General Outline*

The area to be covered will be;

- From the brick on the rear grate shelf to the rear floor brick at the top edge of the incline.
- From the insulation on one side of the arch to the other.
- The insulation on the incline should be fully covered.

Use full thickness brick to cover the area.

The top brick will need to be trimmed to allow a smooth transition from the incline to the rear floor.

## Incline – Detailed 2X8 Example

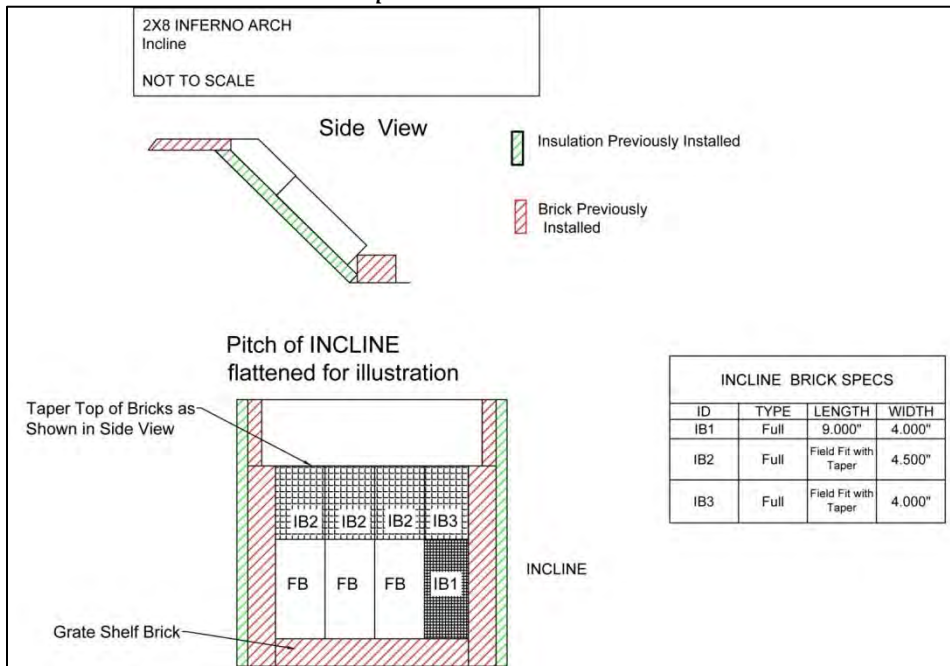

## Insulating a 2X6 Arch for a Raised Flue Pan Set

A detailed insulation procedure for the 2X6 arch for a raised flue pan set is presented in this section as the insulating of this arch differs from the arches larger than 2X6. The 2X6 arch is provided with a single factory installed baffle. All larger arches for raised flue pan sets are provided with two factory installed baffles.

The order is as follows:

1. INSULATION BOARD
  - a. Left Side Board Insulation
  - b. Right Side Board Insulation
  - c. Back Board Insulation
  - d. Top View Board Insulation
  - e. Ash Pit Rear Board Insulation
2. BRICKING
  - a. Floor Behind Factory Baffle Brick
  - b. Left Side Brick
  - c. Right Side Brick
  - d. Grate Area Brick
    - i. Front Grate Shelf Brick
    - ii. Install Grates
    - iii. Rear Grate Shelf Brick
  - e. Incline to Top of Front Factory Baffle Brick
  - f. Rear Baffle
  - g. Baffle Area Completion

Insulation Board

Left Side

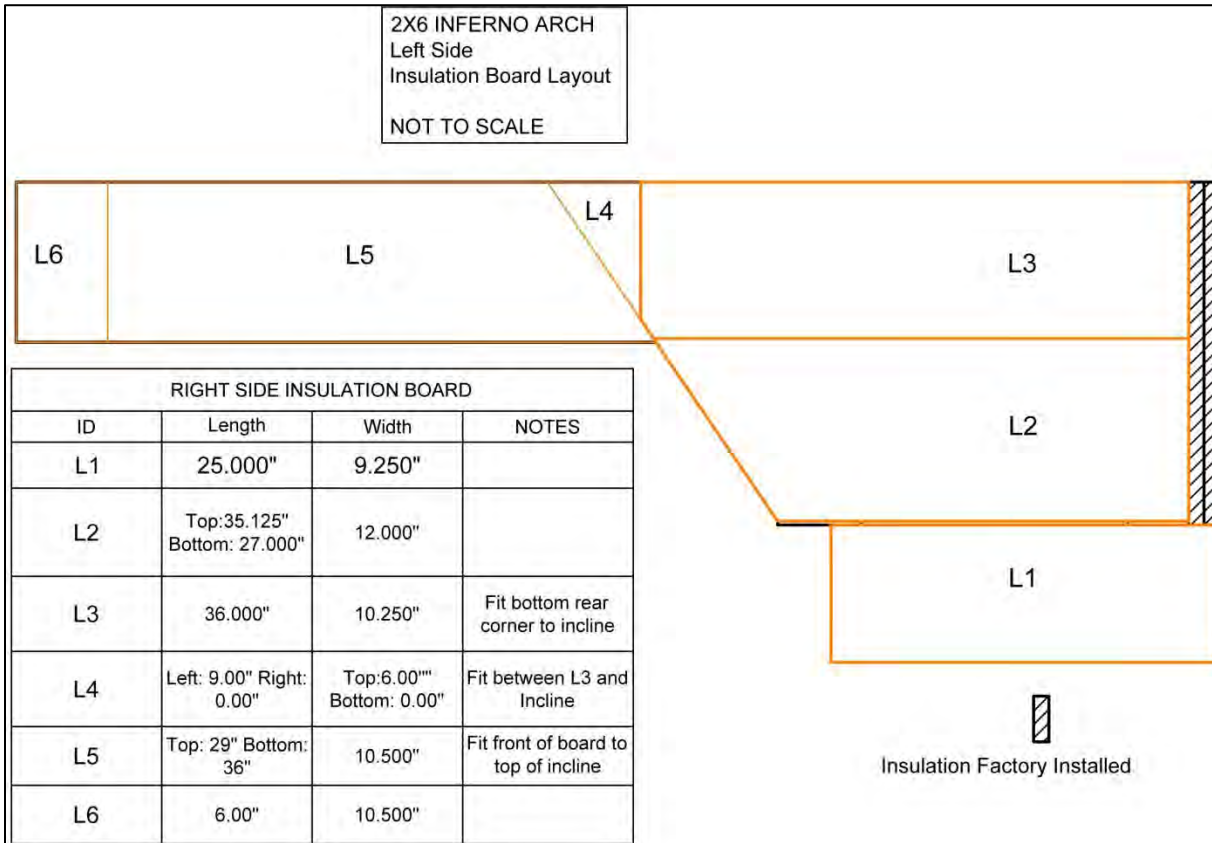

Right Side

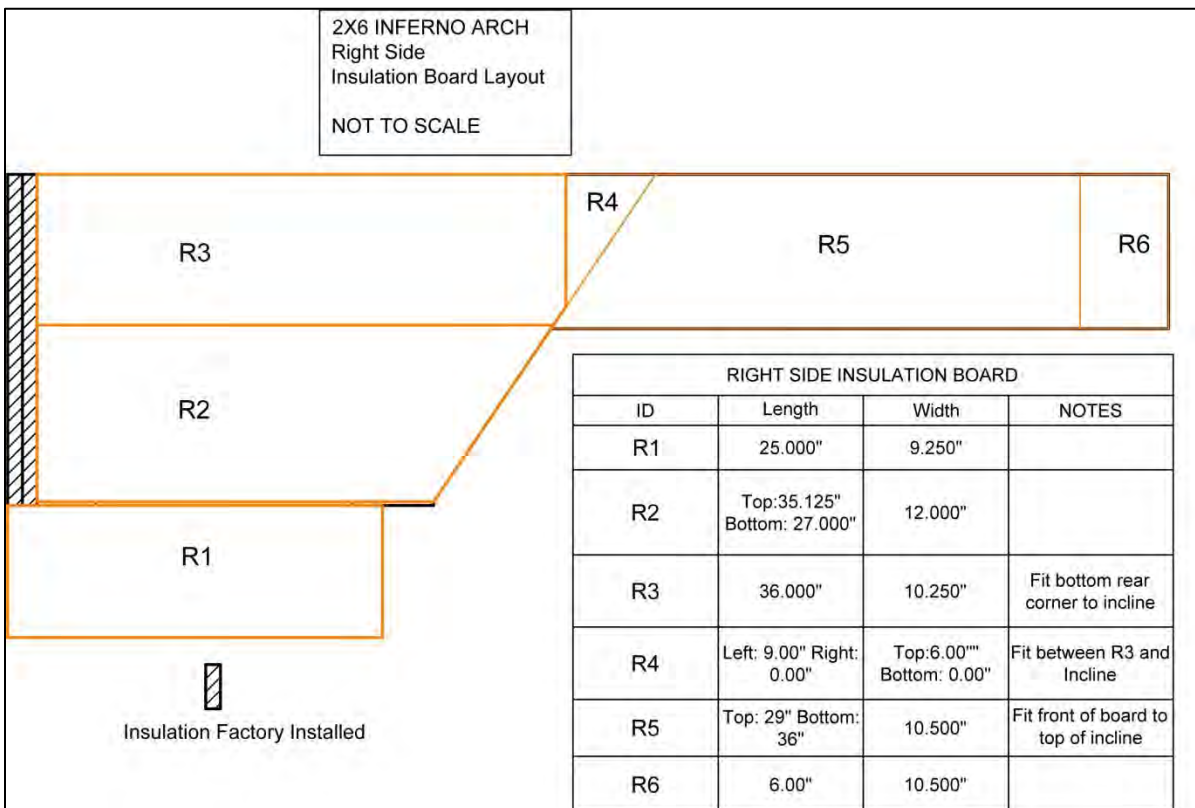



Back

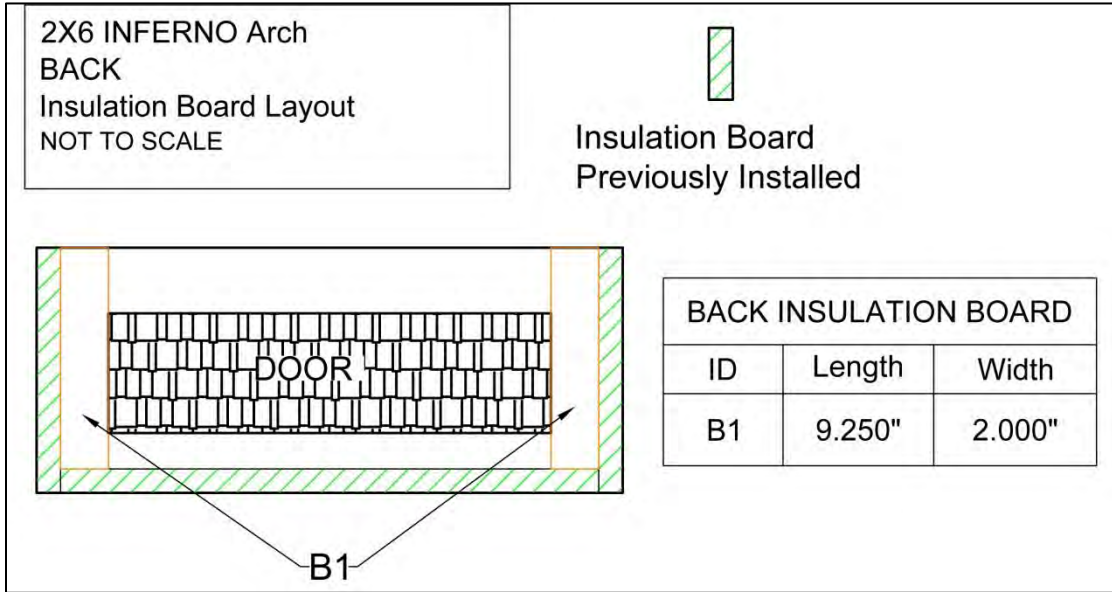

Incline

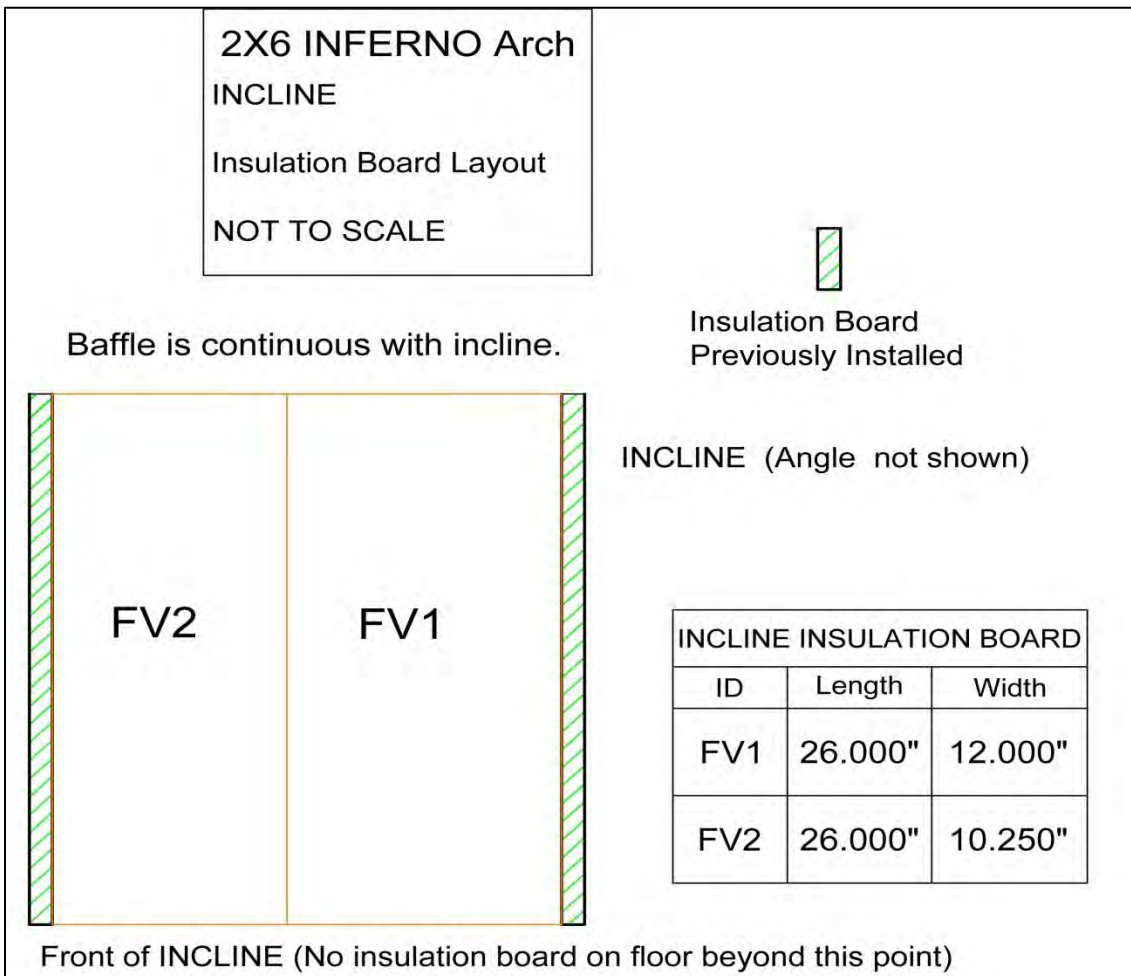

Ash Pit Rear

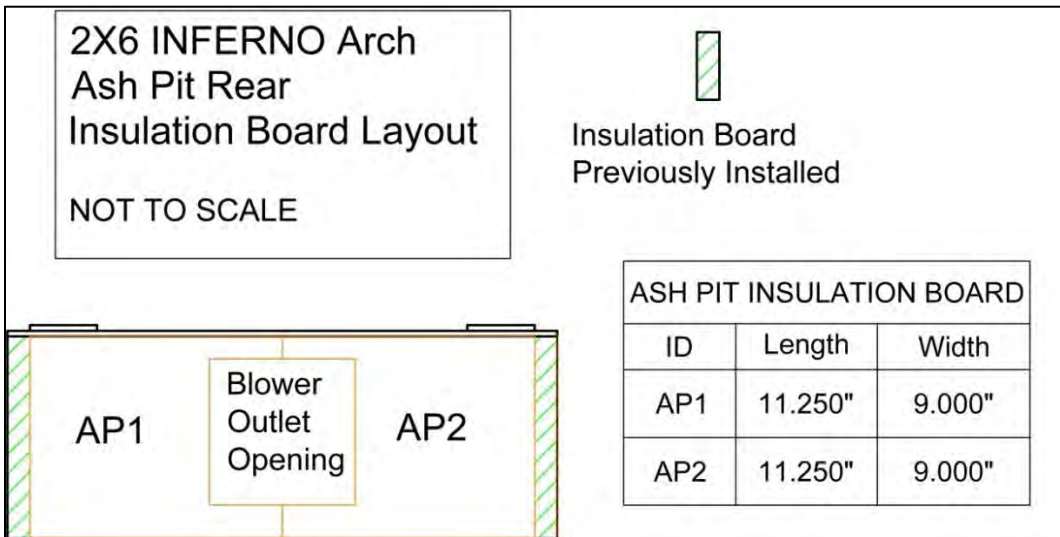

Bricking

Floor Behind Factory Baffle

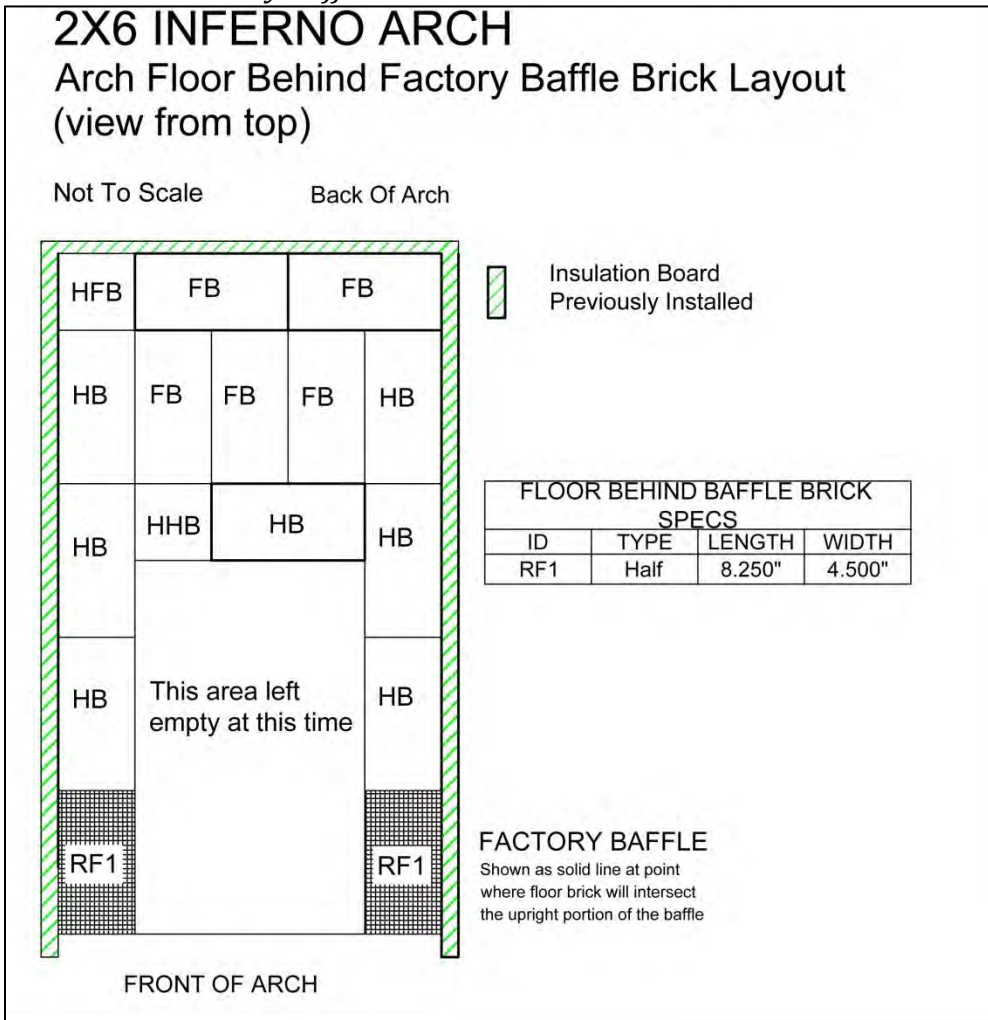



Left Side

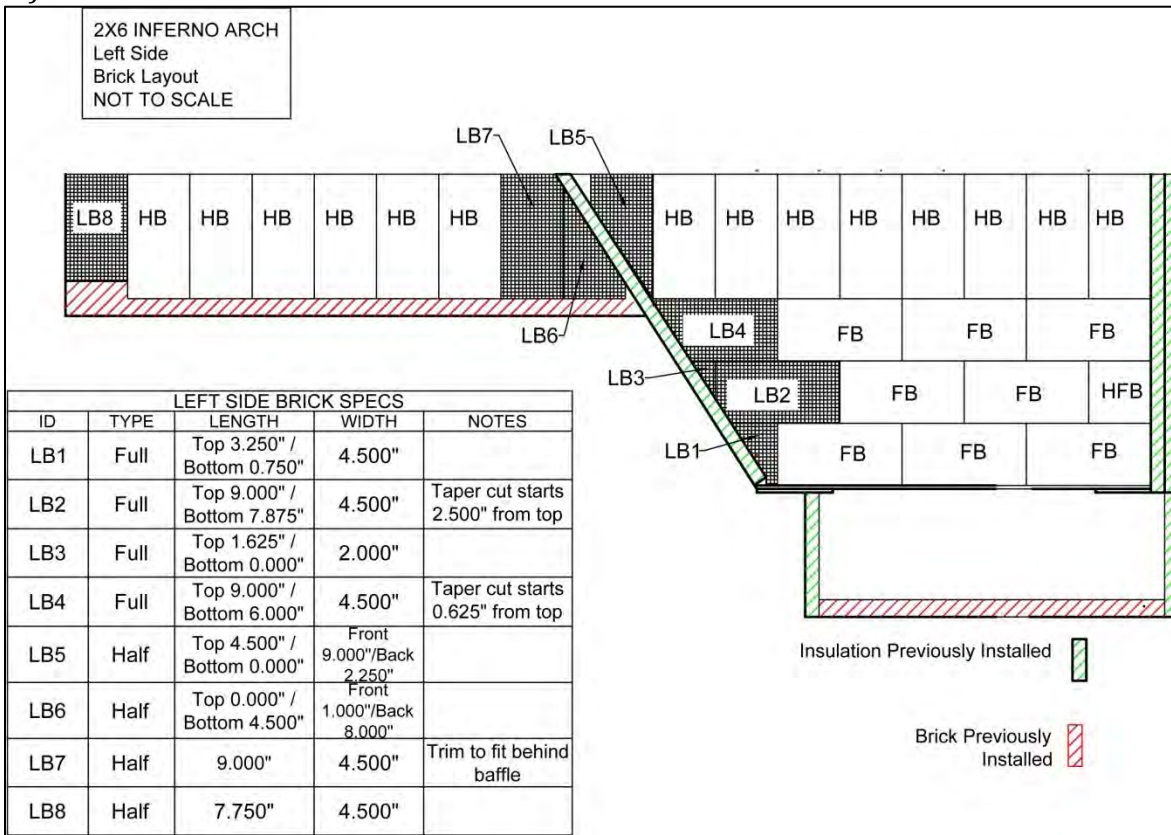

Right Side

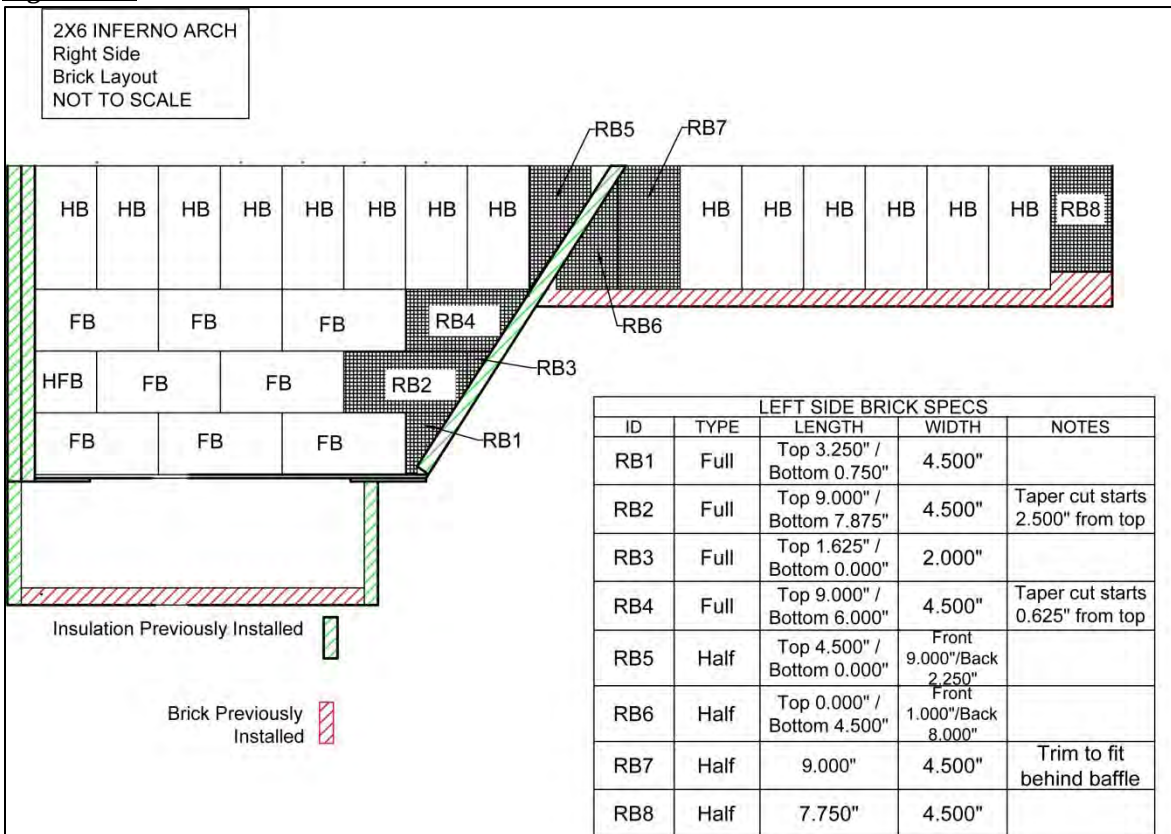

## Grate Area

### Front Grate Shelf

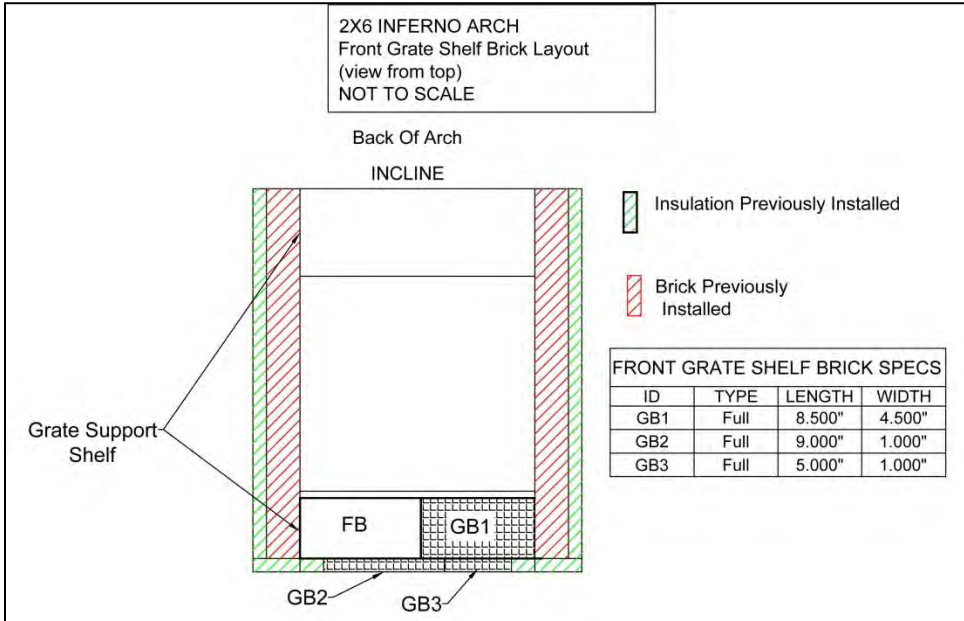

### Install Grates

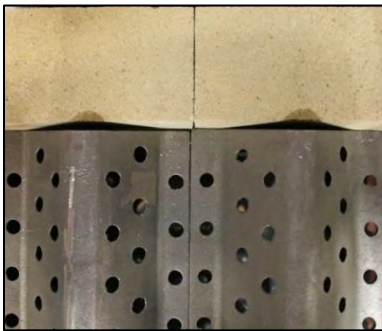

Place the two arch grates into the arch so the front of the grates are against the stainless steel front floor plate of the arch. The grates fit between the grate spacer band irons of the arch and will rest on the front and back support shelves by approximately 1". The grate may need to be flipped around to obtain the best fit as the grate castings vary slightly in size.

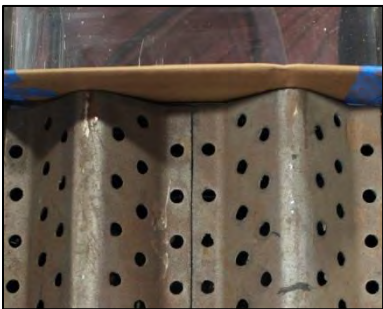

Obtain a piece of "C flute" cardboard (most common type of cardboard). Fold it into thirds along the length and tape with a non-plastic tape (ex. masking tape). Place it behind the grates toward the rear of the arch. The cardboard will provide the spacing needed to remove the grates after the insulating materials have been fit in place. The cardboard can be left in place as it will be consumed during the first firing of the arch.



#### PROPER ORIENTATION OF GRATES

Grates should be installed so the flat side is down on the supports.

### Rear Grate Shelf

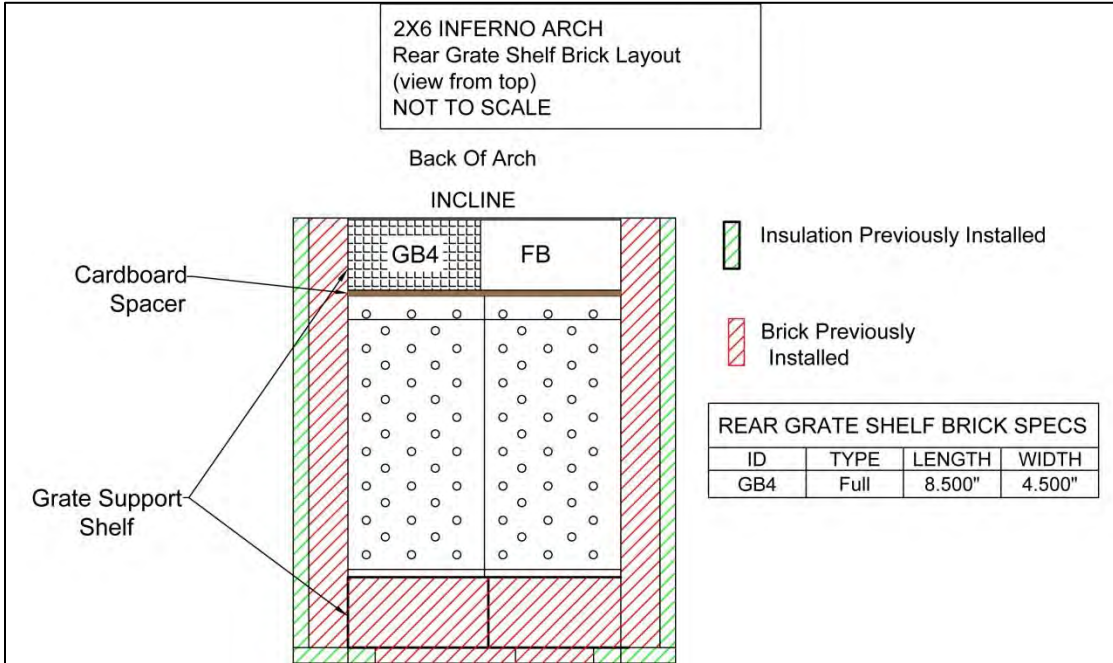

### Incline to Top of Front Factory Baffle

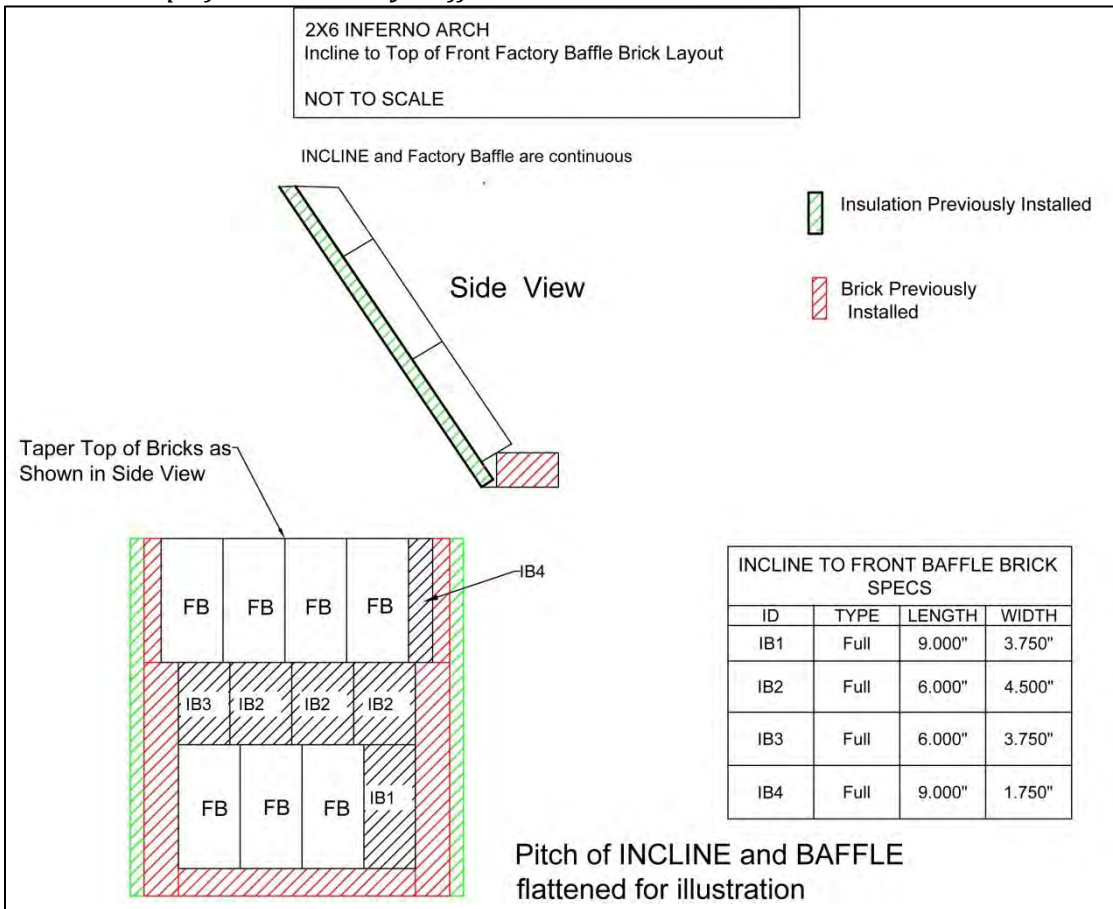



## Rear Baffle

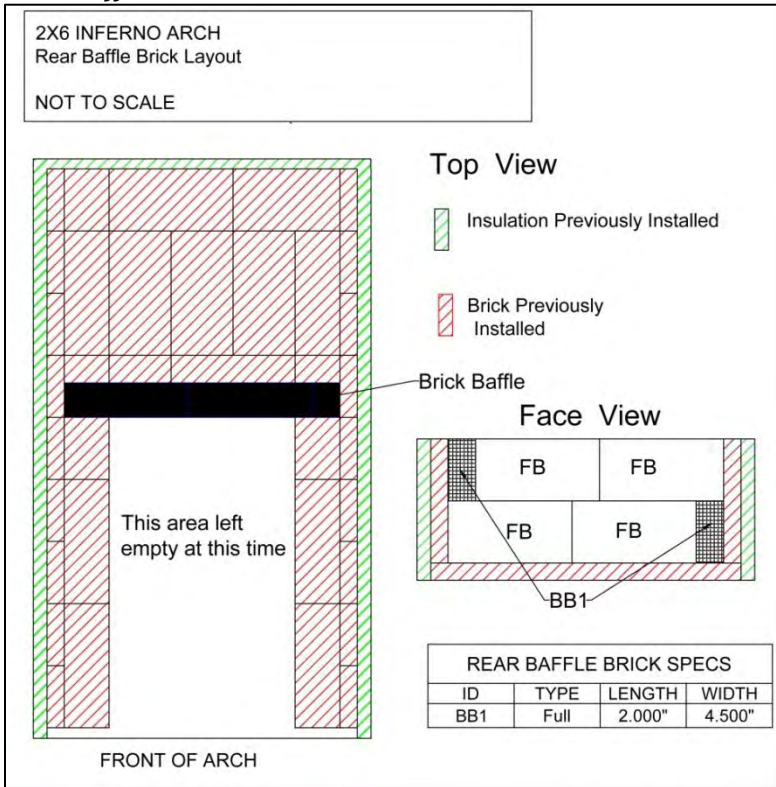

## Baffle Area Completion

To Insulate between and the top of the factory baffle;

1. Using refractory cement, attach a layer of 1" rail gasket across the top of the factory baffle.
2. Fill the open area between the two baffles with vermiculite to 1 1/4" below the bottom of the arch rails.
3. Cement a layer of half bricks over the top of the vermiculite. The bricks should not be higher than the arch rails.

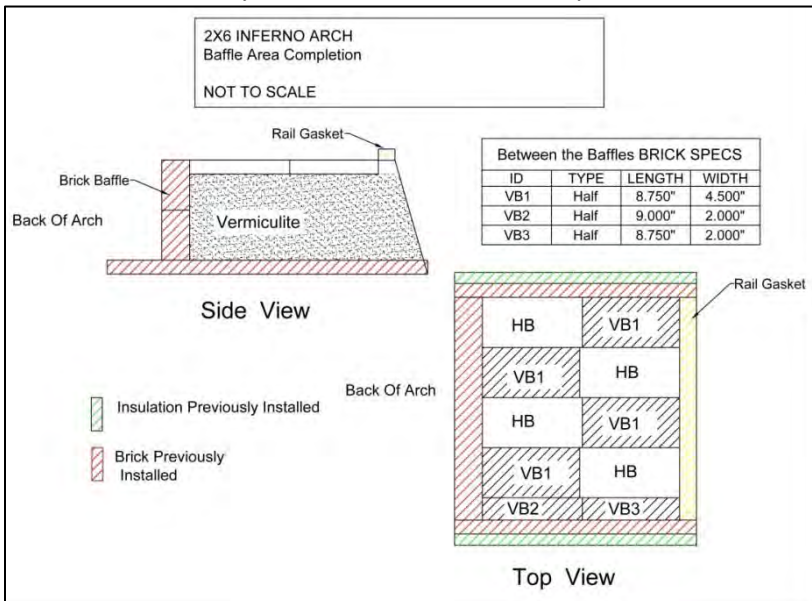

As an option insulation board can be used in place of the bricks over the Vermiculite. If insulation board is used, fill the Vermiculite area up to 1" below the arch rail. Reduce the number of half bricks by the area over the Vermiculite and increase the number of insulation boards to cover the same area. It is recommended a minimum of piecing be done to prevent movement of the insulation board.

# Insulating an Arch for a Raised Flue Pan Set 2X8 or Larger

In the sections below, a generic recommended procedure for insulating an INFERNO arch for a raised or Max Raised flue pan set is described. Each section is followed by a detailed example showing a 2X8 INFERNO arch.

The following diagram indicates the sections of the arch to be insulated.

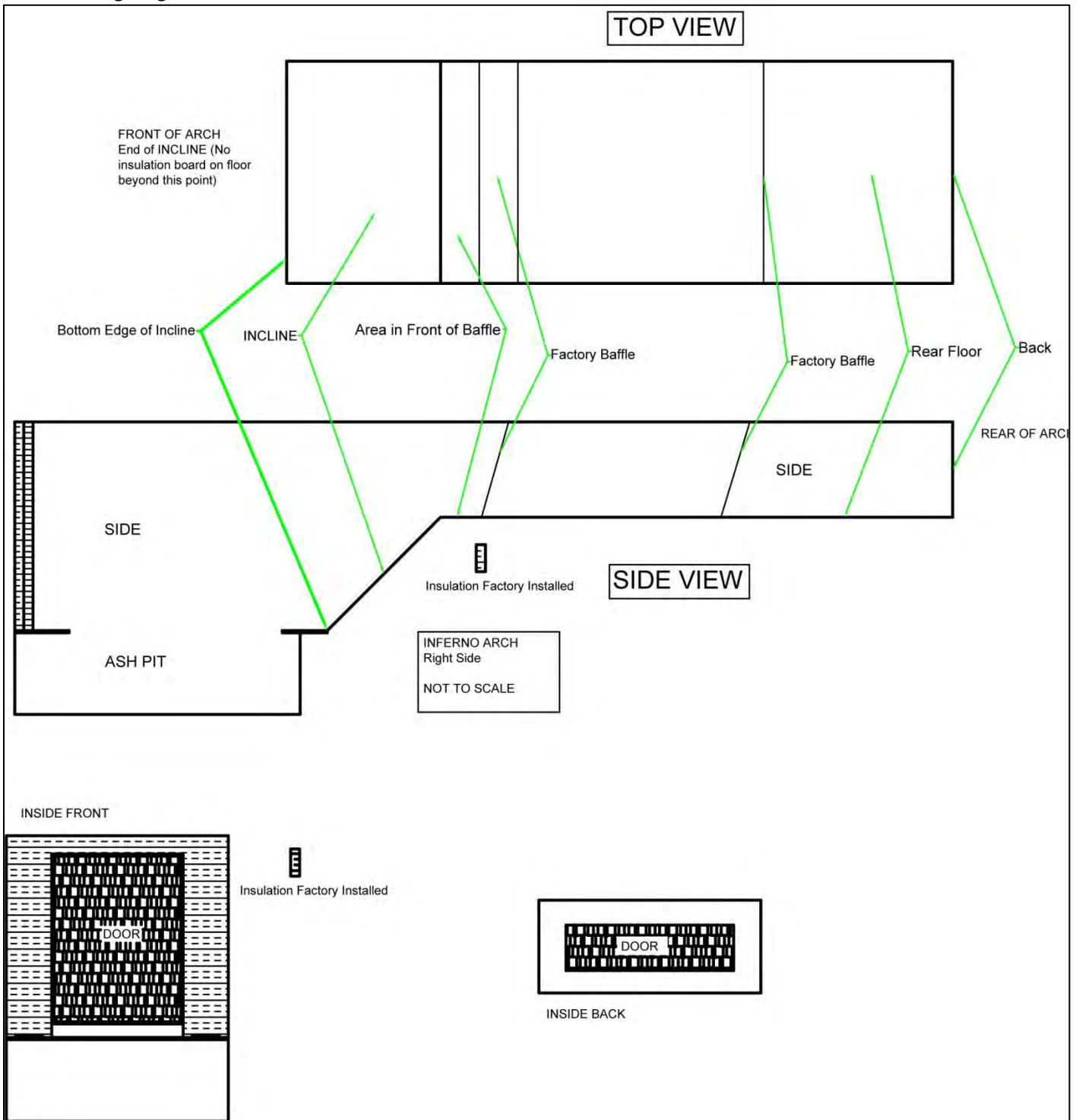

## Insulating the Arch

The order of insulation is as follows:

1. INSULATION BOARD
  - a. Left Side
  - b. Right Side
  - c. Back
  - d. Incline and Baffle
  - e. Ash Pit Rear
2. BRICKING
  - a. Rear Floor From Front Factory Baffle Brick
  - b. Left Side Brick
  - c. Right Side Brick
  - d. Grate Area Brick
    - i. Front Grate Shelf Brick
    - ii. Install Grates
    - iii. Rear Grate Shelf Brick
  - e. Incline to Top of Front Factory Baffle Brick
  - f. Behind Rear Factory Baffle
  - g. Baffle Area Completion

### Insulation Board

#### *Left and Right Side – General Outline*

Right side shown – mirror for left side.

#### *Step 1*

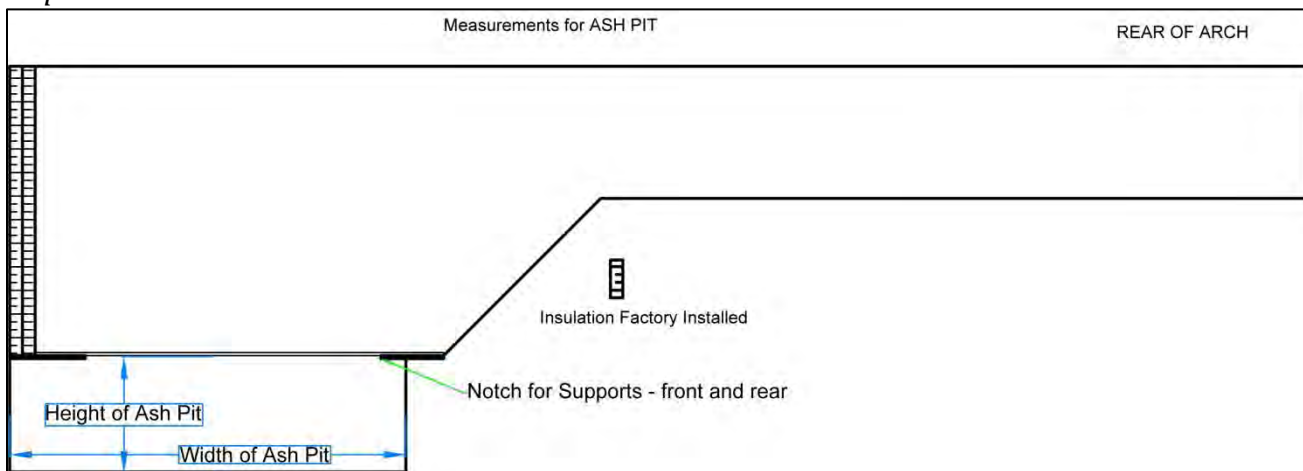

5. Measure the distance from the bottom of the ash pit in the arch to the underside of the band iron going between the grate support shelves. (height of the ash pit)
6. Measure the distance from the front of the ash pit to the rear of the ash pit. (width of the ash pit)
7. Using the measurements, determine the best way to use the pieces of insulation board and cut them to fit. Notch out the area for the grate support shelves.
8. Double check the fit then cement the pieces into place.

### Step 2

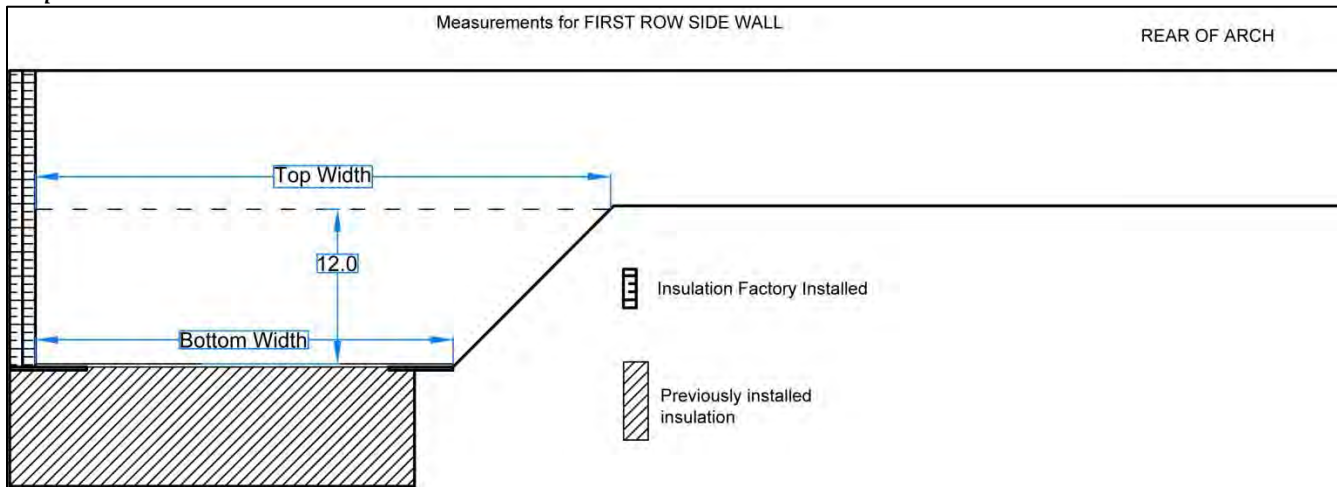

1. Measure the distance from the insulation in the front of the arch to the bottom of the incline (bottom width). If the bottom width is less than 36" then board will need to be cut to fit the incline. If the measurement exceeds 36" place a full insulation board in place and determine the distance from the rear of the insulation board to the incline at the top and bottom.
2. Using the measurements, determine the best way to use the pieces of insulation board and cut them to fit.
3. Double check the fit and cement the pieces into place.

### Step 3

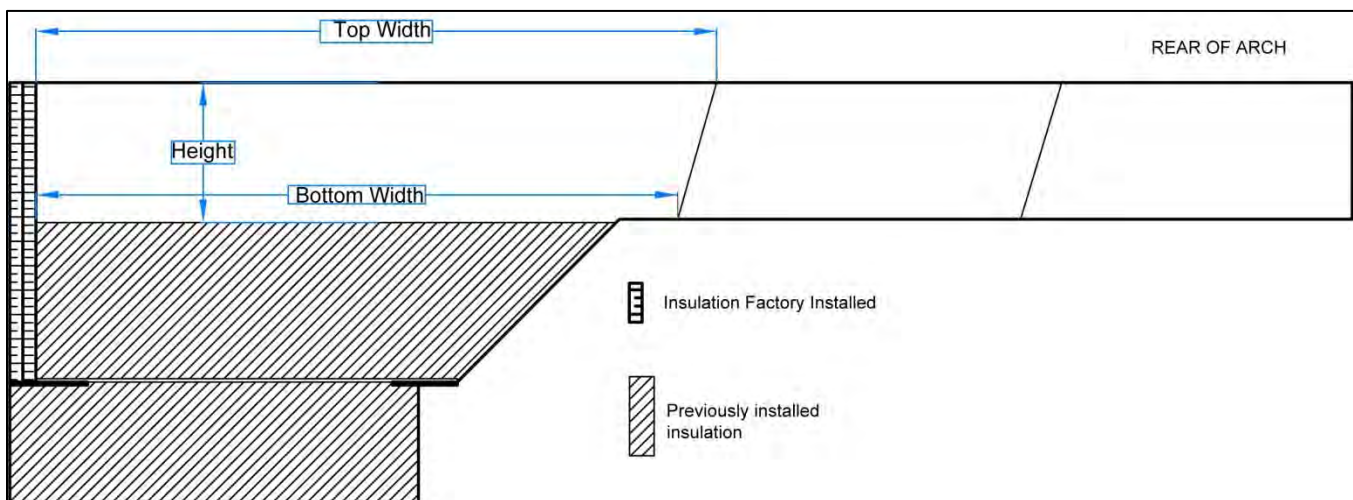

1. Measure the distance from the top of the first row of insulation board to the underside of the arch rail. (Height)
2. Measure the distance from the insulation in the front to the bottom of the baffle. (Bottom Width)
3. Measure the distance from the insulation in the front to the top of the baffle. (Top Width)
4. If the Top Width exceeds 36", fit a full sheet into the area starting from the front insulation. Fit another piece between the end of the first insulation board and the incline, cutting the board to fit to the baffle face.
5. If the Top Width does not exceed 36", fit a full sheet into the area, cutting the board to fit to the baffle face.
6. Double check the fit and cement the piece(s) into place.



### Step 4

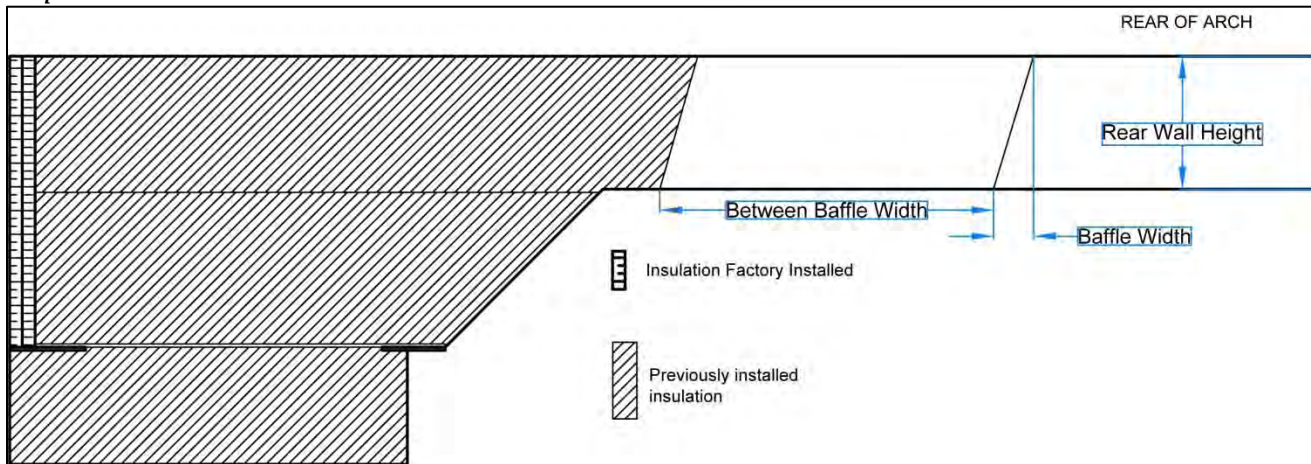

1. Measure the distance from the rear floor to the underside of the arch rail. (Rear Wall Height)
2. Measure the distance from the bottom of the front baffle to the bottom of the rear baffle. (Between Baffle Width)
3. Place a straight edge from where the top lip of the rear baffle meets the arch rail down to arch floor. Measure between the bottom of the straight edge and the inside bottom of the baffle. Subtract 1 1/2". (Baffle Width)
4. Add the Baffle Width and the Between Baffle Width together. If the total exceeds 36", the area between the baffles will require more than one full sheet.
5. Using the measurements, fit piece(s) between the baffles starting against the back of the front baffle. NOTE: Use the Baffle Width measurement as a starting mark to fit the sheet to the inside of the baffle.

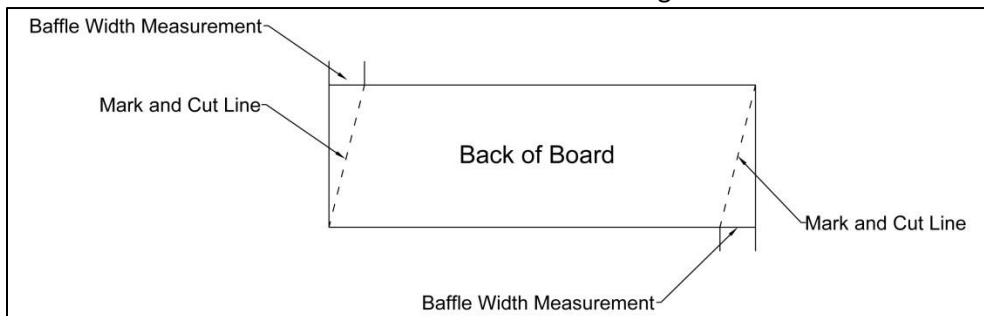

6. Double check the fit then cement the piece(s) into place.

### Step 5

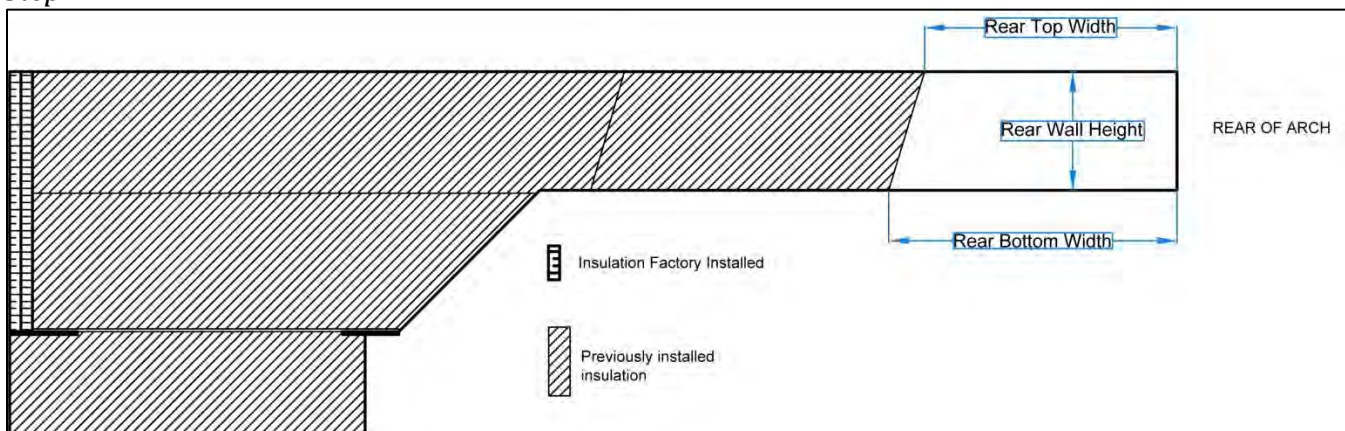

1. Measure the distance from the rear floor to the underside of the arch rail. (Rear Wall Height)
2. Measure the distance from the inside rear of the arch to the bottom of the rear incline. (Rear Bottom Width)
3. Measure the distance from the inside rear of the arch to the point where the inside of the baffle meets the arch rail. (Rear Top Width)
4. Using the measurements, determine the best way to use the pieces of insulation board and cut them to fit.
5. Double check the fit and cement the pieces into place.

COMPLETED SIDE

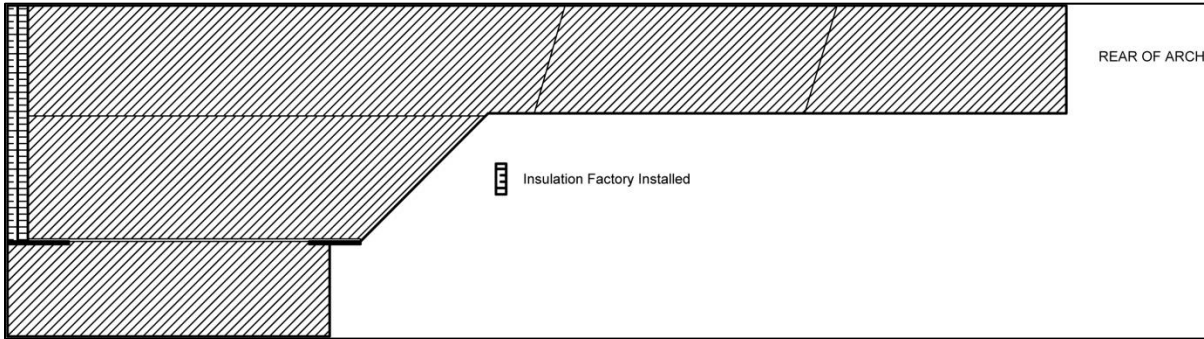

Left and Right Sides – Detailed 2X8 Example

Right Side shown

2X8 INFERNO ARCH  
Right Side  
Insulation Board Layout  
NOT TO SCALE

Insulation Factory Installed

Factory Installed Baffles

RIGHT SIDE INSULATION BOARD			
ID	Length	Width	NOTES
R1	31.500"	9.000"	
R2	Top: 36.000" Bottom: 32.5"	12.000"	Taper Cut starts 8.500" from top
R3	36.000"	11.000"	
R4	Top: 9" Bottom: 0"	9.000"	
R5	Top: 16.500" Bottom: 13.500"	10.250"	
R6	Top: 22.5" Bottom: 25.5"	10.250"	
R7	Top: 26.5" Bottom: 26.5"	10.250"	Start with a piece long enough to go from the bottom of the front baffle to the top of the rear baffle then cut to fit

*Back - General Outline*

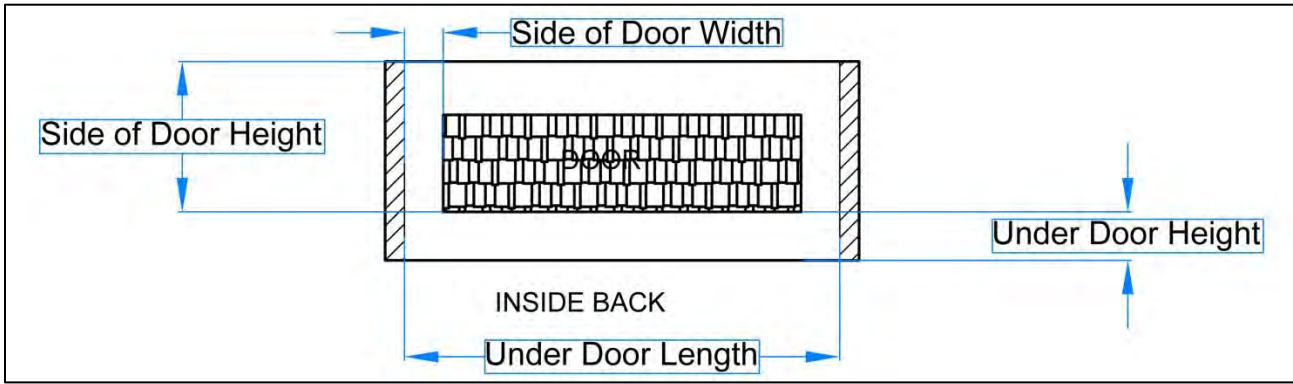

1. Measure between the insulation board installed on each side of the arch. (Under Door Length)
2. Measure from the angle iron at the bottom of the back to the bottom of the door. (Under Door Width)
3. Cut a piece of insulation board to fit in the area.
4. Double check the fit then cement into place.
5. Measure the distance between the door and the insulation on one side of the arch. (Side of Door Width)
6. Measure the distance from the top of the insulation board installed below the door and the bottom of the arch rail. (Side of Door Height)
7. Using the measurements, determine the best way to use the insulation board and cut them to fit. You will need to side pieces.
8. Double check the fit and cement the pieces into place.

*Back - Detailed 2X8 Example*

2X8 INFERNO Arch  
BACK  
Insulation Board Layout  
NOT TO SCALE



Insulation Board  
Previously Installed

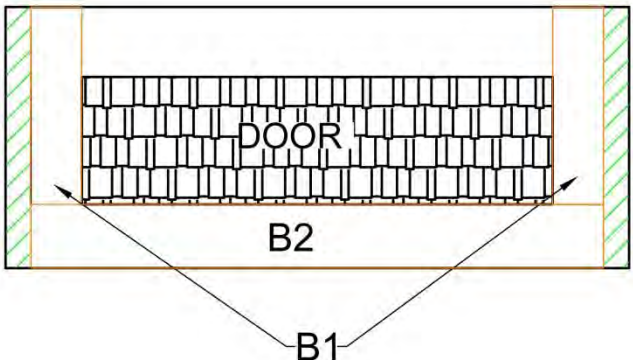

BACK INSULATION BOARD		
ID	Length	Width
B1	7.750"	2.000"
B2	22.500"	2.500"

## Incline and Front Baffle – General Outline

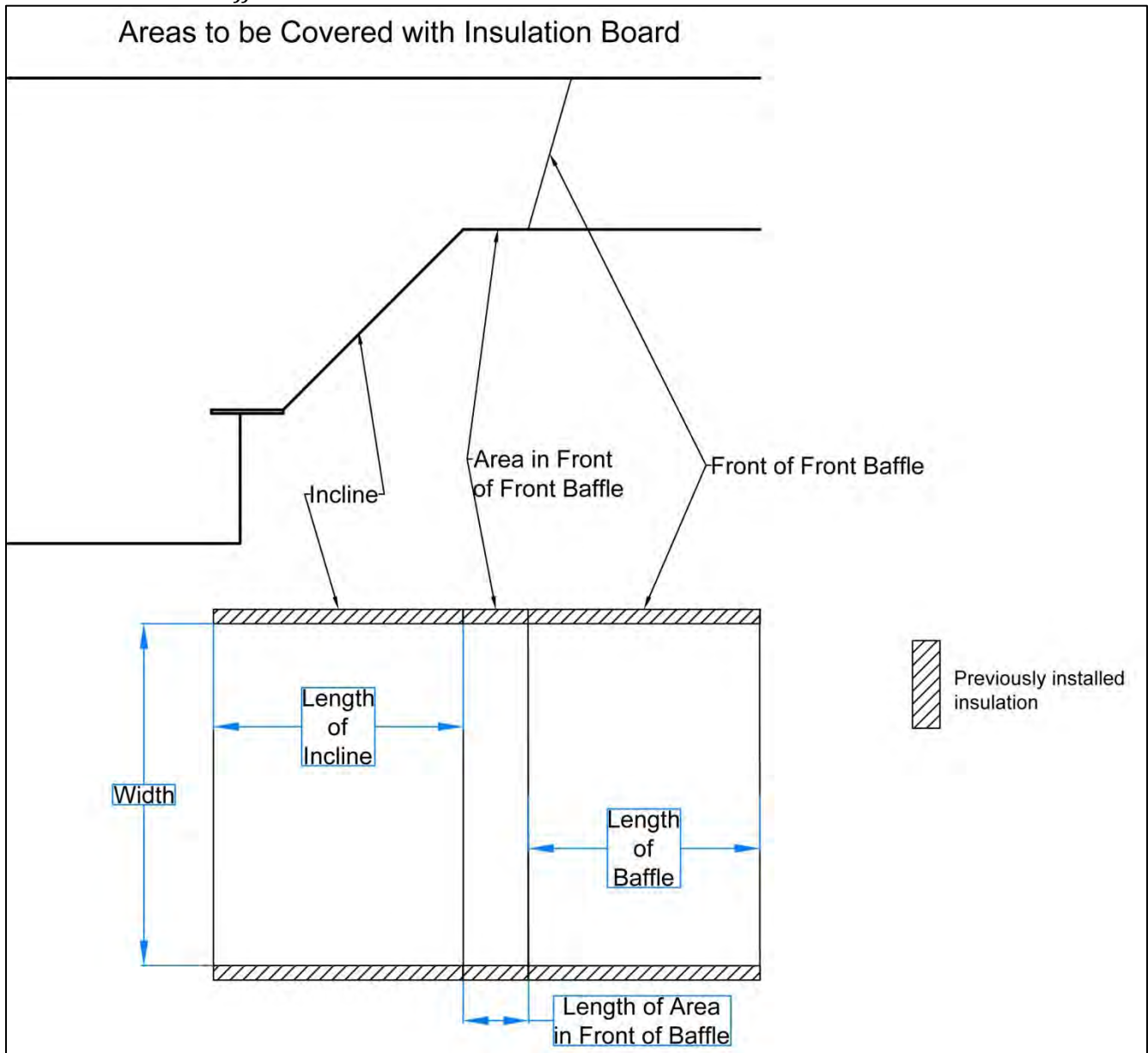

1. Measure the distance between the insulation on each arch side. (Width)
2. Measure the distance from the bottom of the incline to the top of the incline where it meets the rear floor. (Length of the Incline)
3. Measure the distance from the top of the incline to the bottom of the baffle. (Length of Area in Front of Baffle)
4. Measure the distance from the bottom of the baffle to the top of the baffle. (Length of Baffle)
5. Using the measurements, determine the number of and the best way to layout the piece(s) of insulation board to cover the areas. Cut the pieces to fit.
6. Double check the fit and cement the pieces into place.



### Incline and Front Baffle – Detailed 2X8 Example

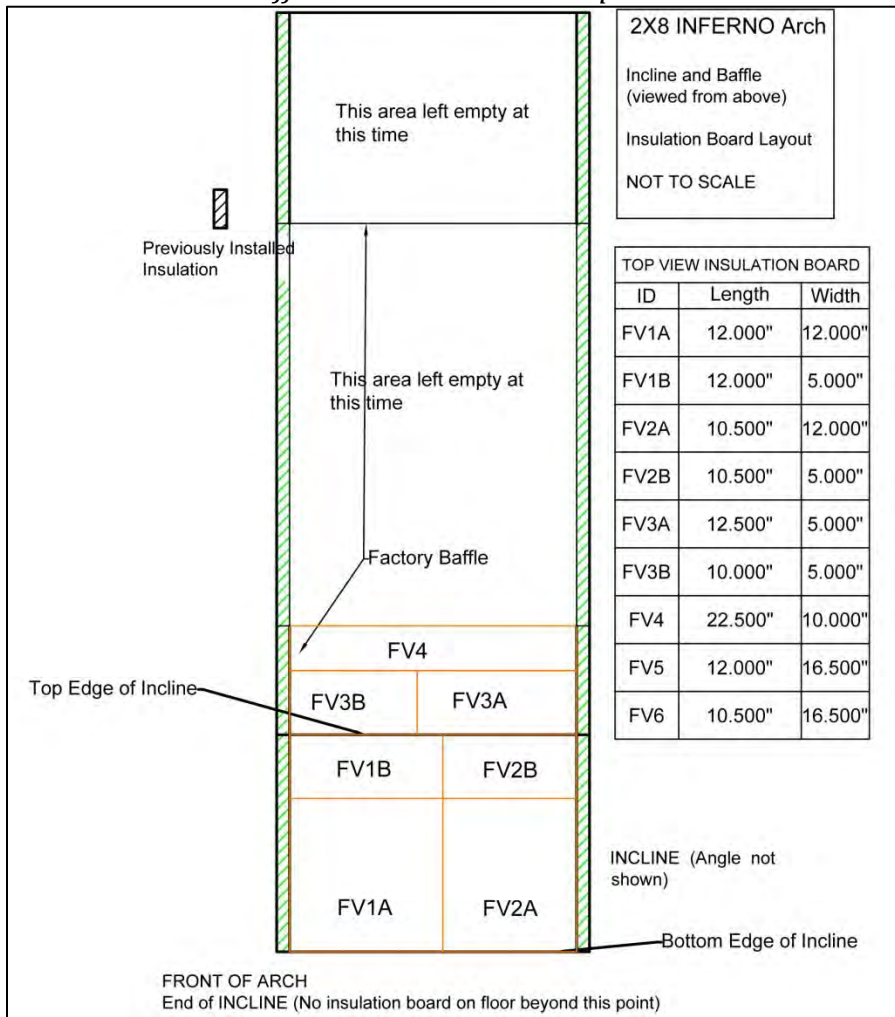

### Ash Pit Rear – General Outline

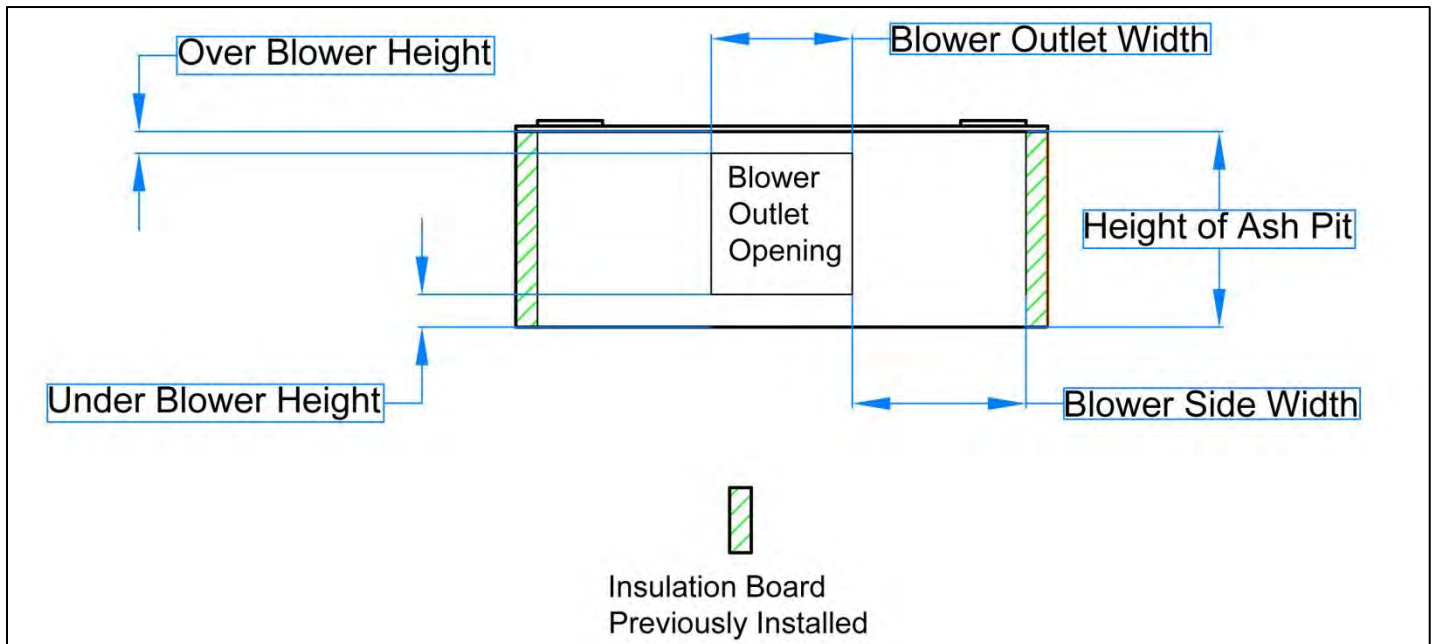

1. Measure from the edge of the blower opening to the insulation on the side of the arch. (Blower Side Width)

2. Measure the distance between the angle iron on the bottom of the front to the underside of the front grate shelf. (Height of Ash Pit)
3. Measure the distance between the bottom of the arch front and the bottom of the blower air outlet. (Under Blower Height)
4. Measure the Distance between the top of the blower air outlet and the bottom of the grate shelf. (Over Blower Height)
5. Measure the width of the blower opening. (Blower Outlet Width)
6. Using the measurements, determine the number of and the best way to layout the piece(s) of insulation board to cover the area. Cut the pieces to fit.
7. Double check the fit then cement the piece(s) into place.

NOTE: INFERNO arches 5 foot and 6 foot in width have 2 blowers and air outlets. The same general fitting process can be used with the exceptions:

- The Blower Side Width will be the distance from the outside of each blower air outlet
- A piece of insulation board will need to be fit between the insides of the two blower air outlets.

*Ash Pit Rear – Detailed 2X8 Example*

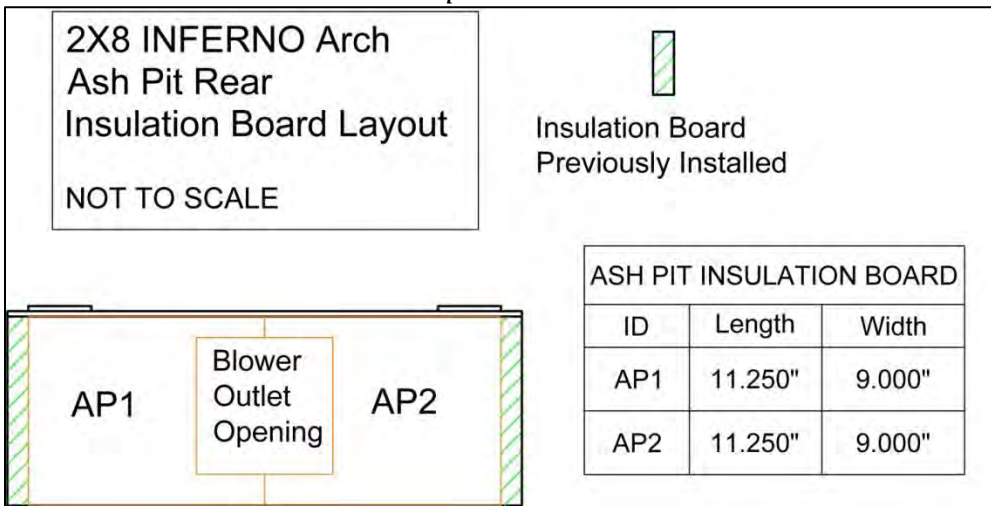

Bricking

*Rear Floor – General Outline*

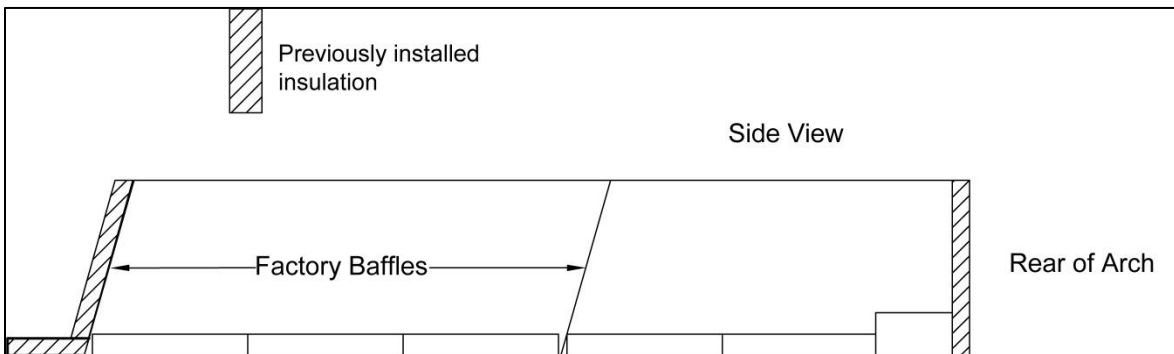



1. Start a row of bricks behind the front baffle by laying a half thickness brick face down on the floor and lengthwise against the insulation on the side of the arch. Continue the row until the front of the rear baffle is reached. The last brick may need to be cut to fit against the baffle.
2. Repeat this process for the other side of the arch.
3. Double check the fit and cement the bricks into place.

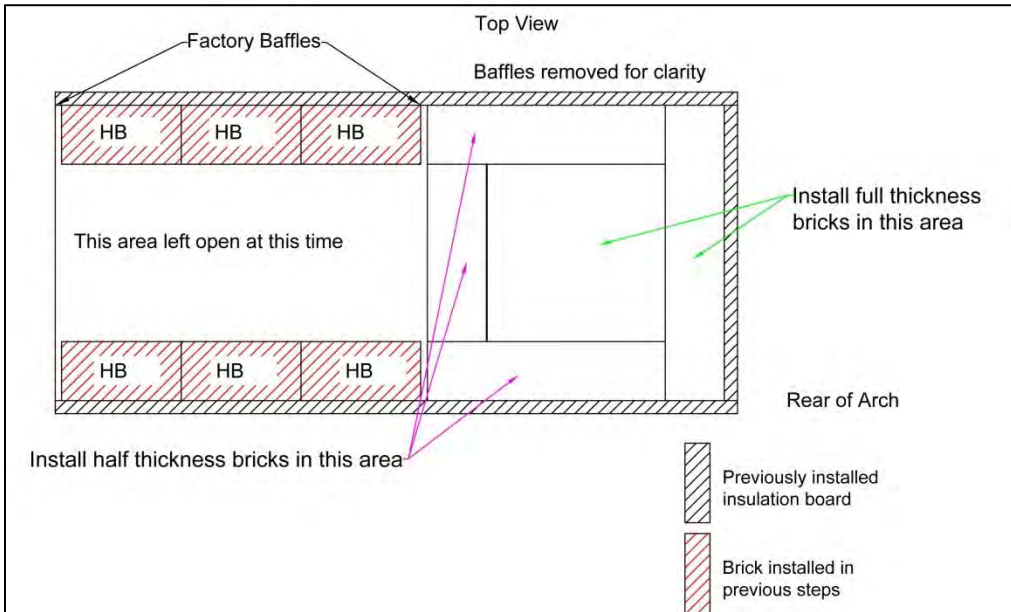

1. Place a row of full thickness bricks against the back of the arch. The bricks should be placed lengthwise against the rear of the arch.
2. Place a row of half thickness bricks starting at the full thickness bricks in the rear. The bricks should be run lengthwise against the insulation on the side of the arch. Continue the row until the back of the rear baffle is reached. The last brick in the row may need to be cut to fit against the baffle. Repeat for the other side of the arch
3. Place a row of half thickness bricks between the rows of bricks on the sides of the arch. The row of bricks should be placed lengthwise against the back of the baffle.
4. Fit full bricks in the unbricked area of the arch floor.
5. Double check the fit and cement the bricks into place.

## Rear Floor – Detailed 2X8 Example

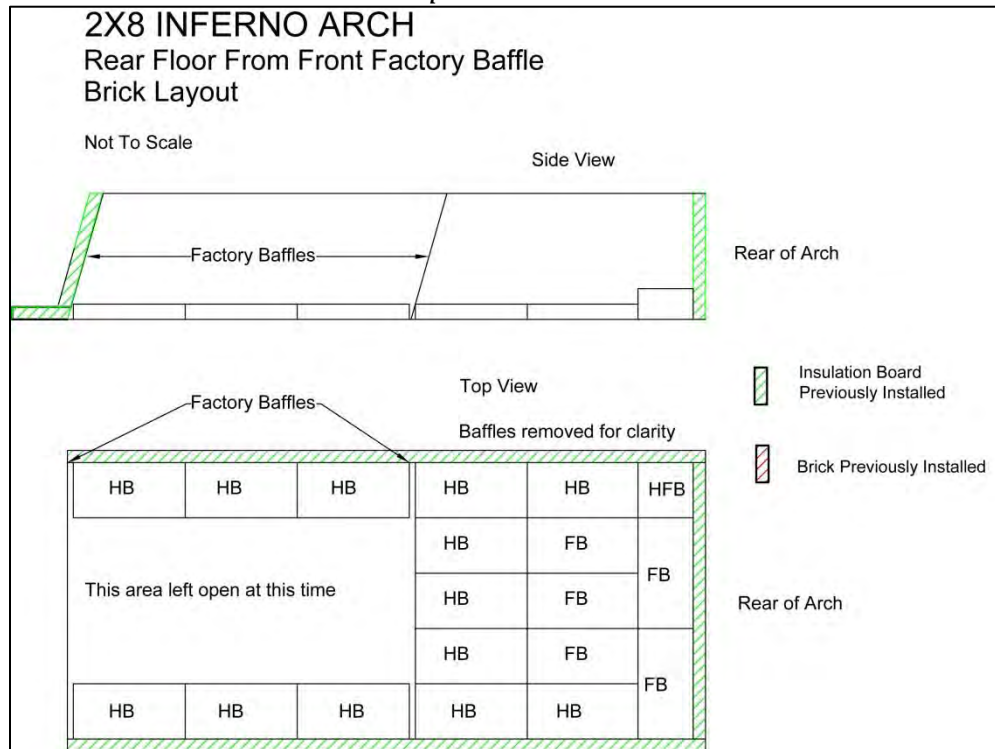

## Left and Right Sides – General Outline

The areas to be covered by bricking in this section are as follows;

- From the insulation on the face of the incline to the inside of the arch front with full thickness bricks
- From the insulation on the face of the baffle to the inside of the arch front with half thickness bricks
- Between the baffles with half thickness bricks
- Between the back of the rear baffle to the inside of the rear of the arch with half thickness bricks

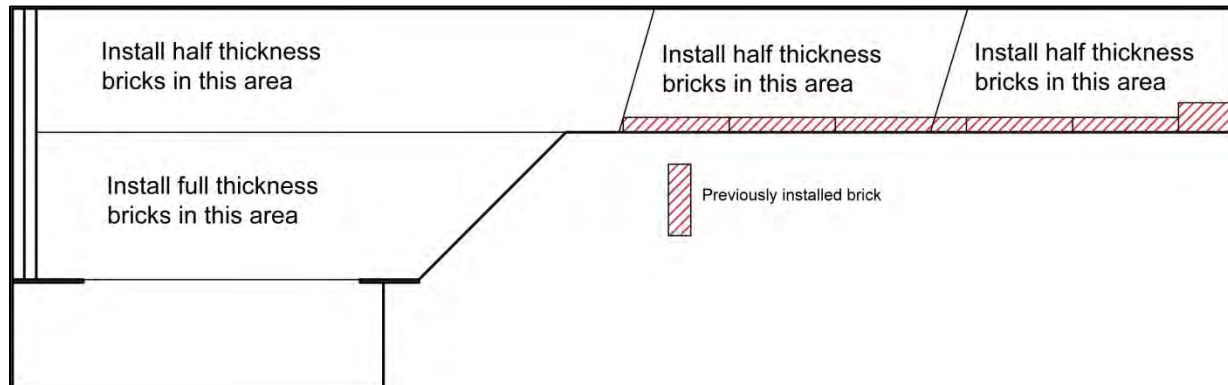

The first three rows over the band iron grate spacers will be horizontal rows of full thickness brick. This will be followed by a row of vertically oriented half thickness bricks. Using half thickness bricks in this manner maximizes the area of the syrup pan being heated.

1. Place a full thickness brick with the short end against the insulation of the door and the brick face against the insulation on the side of the arch.
2. Continue placing the bricks end to end until the insulation board on the front of the incline is reached. The last brick against the incline will need to be trimmed to follow the angle of the incline.
3. Start the next row of bricks with a full thickness brick cut in half (4 ½" X 4 ½").
4. Continue placing the bricks end to end until the insulation board on the front of the incline is reached. The last brick against the incline will need to be trimmed to follow the angle of the incline.

5. Start the third row of bricks with a full brick.
6. Continue placing the bricks end to end until the insulation board on the front of the incline is reached. The last brick against the incline will need to be trimmed to follow the angle of the incline and even with the top edge of the incline, if necessary.
7. Double check the fit and cement the bricks into place.
8. Begin the top row of bricks by placing a half thickness brick on the top of the third row of bricks with the long edge against the insulation in the front of the arch and the brick face against the insulation on the side of the arch.
9. Continue placing bricks until the front insulation on the face of the front baffle is reached. Fit the brick(s) against the baffle.
10. Double check the fit and cement the bricks into place.
11. Begin a row of bricks between the baffles by placing a half thickness brick on the top of the half thickness brick on the rear floor of the arch with the long edge fit the front of the rear baffle and the brick face against the insulation on the side of the arch.
12. Continue placing bricks along the side until the back of the front baffle is reached. Fit the brick(s) to the back of the baffle.
13. Double check the fit and cement the bricks into place.
14. Begin a row at the back of the arch by cutting a half thickness brick to fit the arch side between the full thickness brick on the floor and the underside of the arch rail.
15. Continue a row forward to the back of the rear baffle. Fit the brick(s) to the back of the baffle.
16. Double check the fit and cement the bricks into place.
17. Fill any spaces between the top brick and the underside of the arch rail with rail gasket.

*Left and Right Sides – Detailed 2X8 Example*

Right side shown. Mirror for the left side.

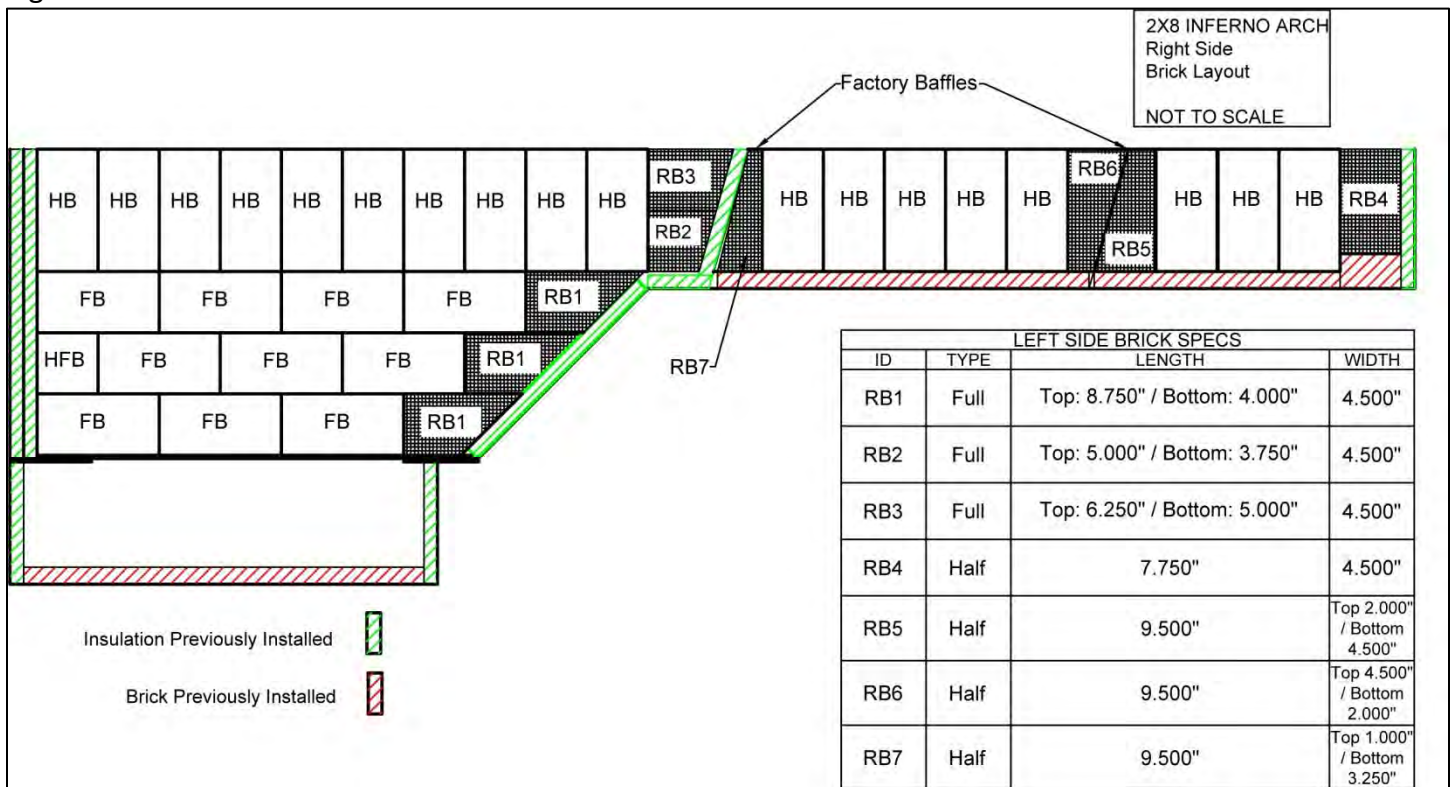

## Grate Area

### Front Grate Shelf – General Outline

The area to be covered will be;

- From the insulation of the front to 1" from the edge of the grate shelf.
- From the insulation on one side of the arch to the other

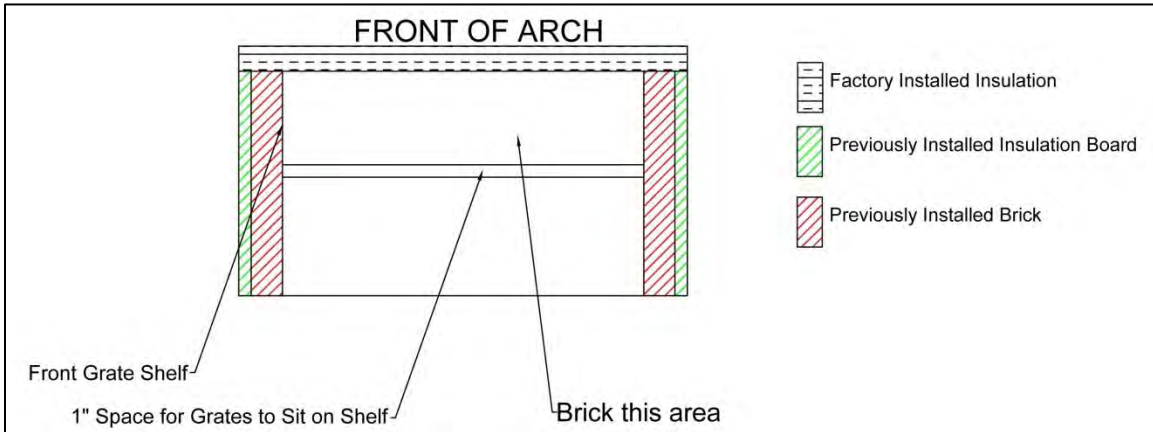

1. Cover the area to be bricked with full thickness bricks placed face down against the grate shelf.
2. Fit the bricks, double check the fit then cement the bricks into place.

### Front Grate Shelf – Detailed 2X8 Example

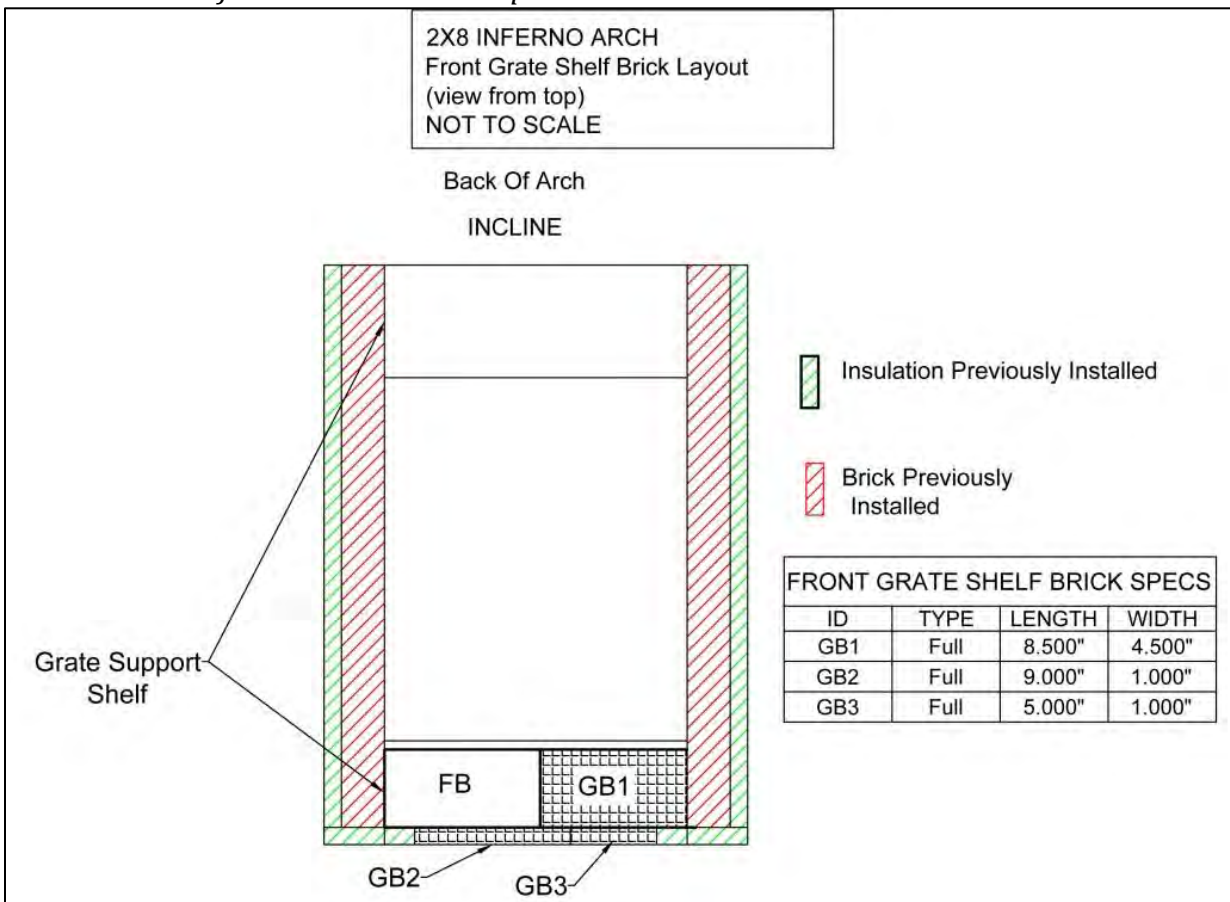

## *Install the Grates*

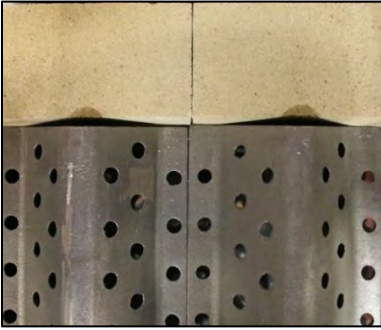

Place the two arch grates into the arch so the front of the grates are against the stainless steel front floor plate of the arch. The grates fit between the band irons at the sides of the arch and will rest on the front and back support shelf by approximately 1" each.

NOTE: To obtain the best fit between the side band irons it may be necessary to flip the grates end for end as the widths of the grates will vary slightly along the length.

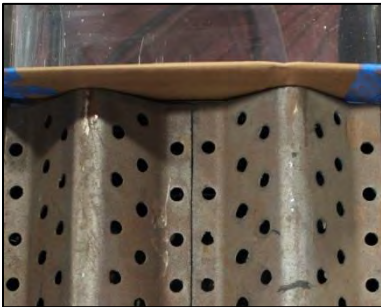

Obtain a piece of "C flute" cardboard (most common type of cardboard). Fold it into thirds along the length and tape with a non-plastic tape (ex. masking tape). Place it behind the grates toward the rear of the arch. The cardboard will provide the spacing needed to remove the grates after the insulating materials have been fit in place. The cardboard can be left in place as it will be consumed during the first firing of the arch.

### PROPER ORIENTATION OF GRATES

Grates should be installed so the flat side is down on the supports.



### *Rear Grate Shelf – General Outline*

The area to be covered will be;

- From the board insulation on the incline to tight to the cardboard from the edge of the grate shelf.
- From the insulation on one side of the arch to the other



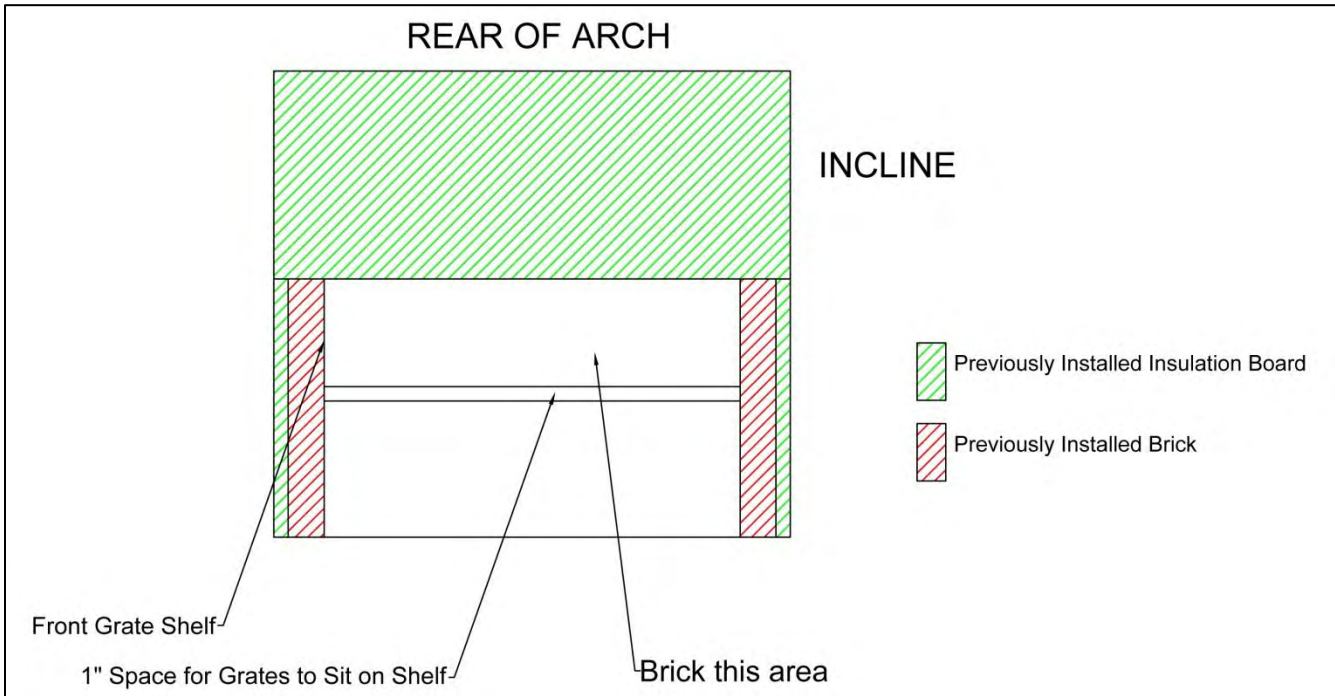

1. Cover the area to be bricked with full thickness bricks placed face down against the grate shelf. Generally the best arrangement will be to place the bricks parallel to the edge of the grate shelf.
2. Fit the bricks, double check the fit then cement the bricks into place.

*Rear Grate Shelf – Detailed 2X8 Example*

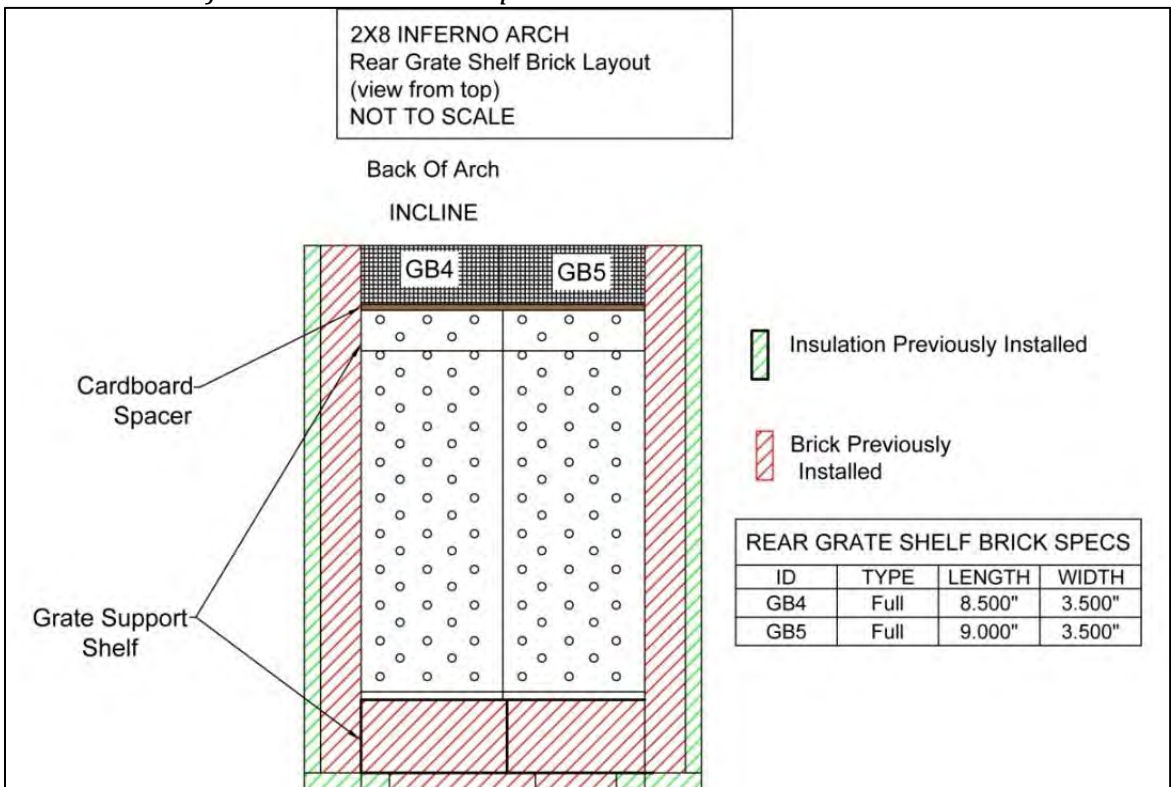



## Incline to Top of Front Baffle – General Outline

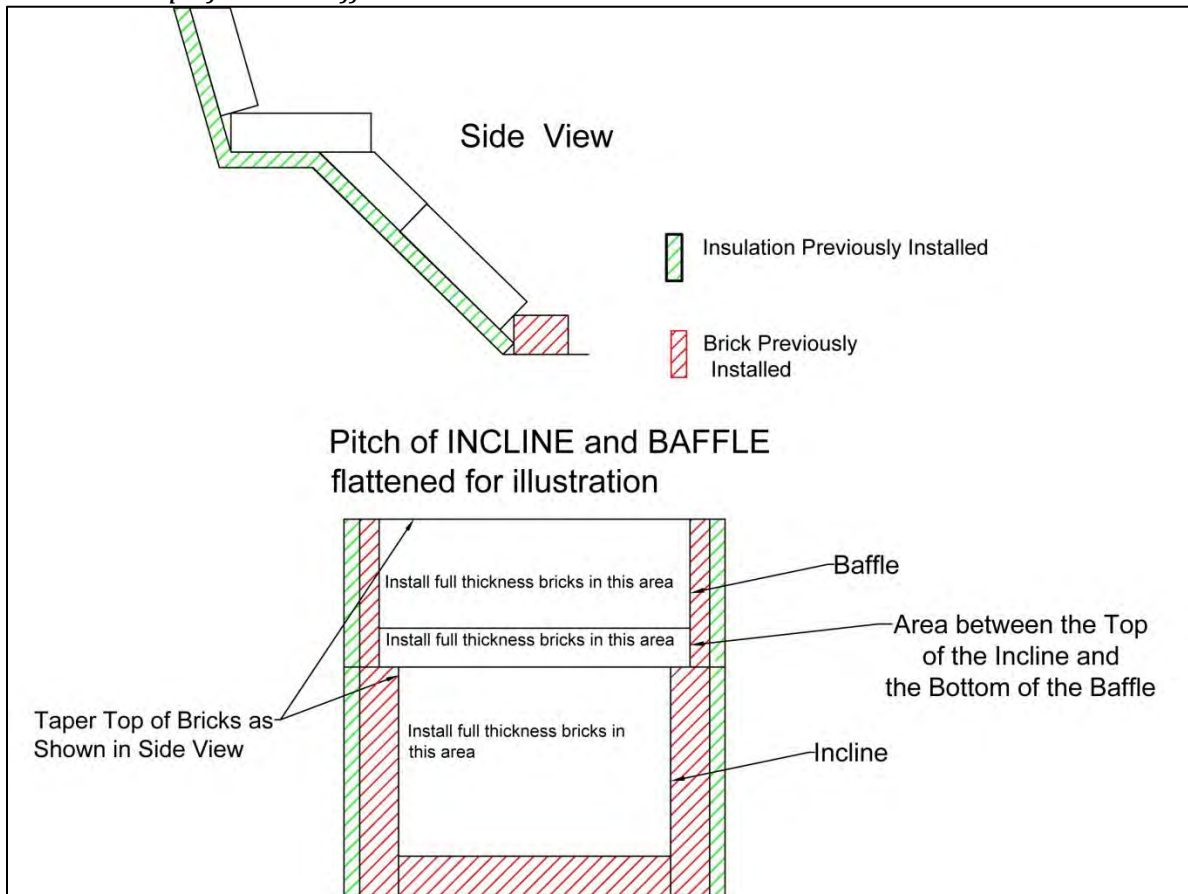

The areas to be covered;

- The incline – cover with full thickness bricks face down
- The area between the top of the incline and the bottom of the baffle – cover with full thickness bricks face down with lengthwise against the bottom of the baffle
- The baffle – cover the insulation board with full thickness bricks at the bottom of the baffle to the top of the baffle. The bricks should not be higher than the top of the baffle.

## Incline to Top of Front Baffle – Detailed 2X8 Example

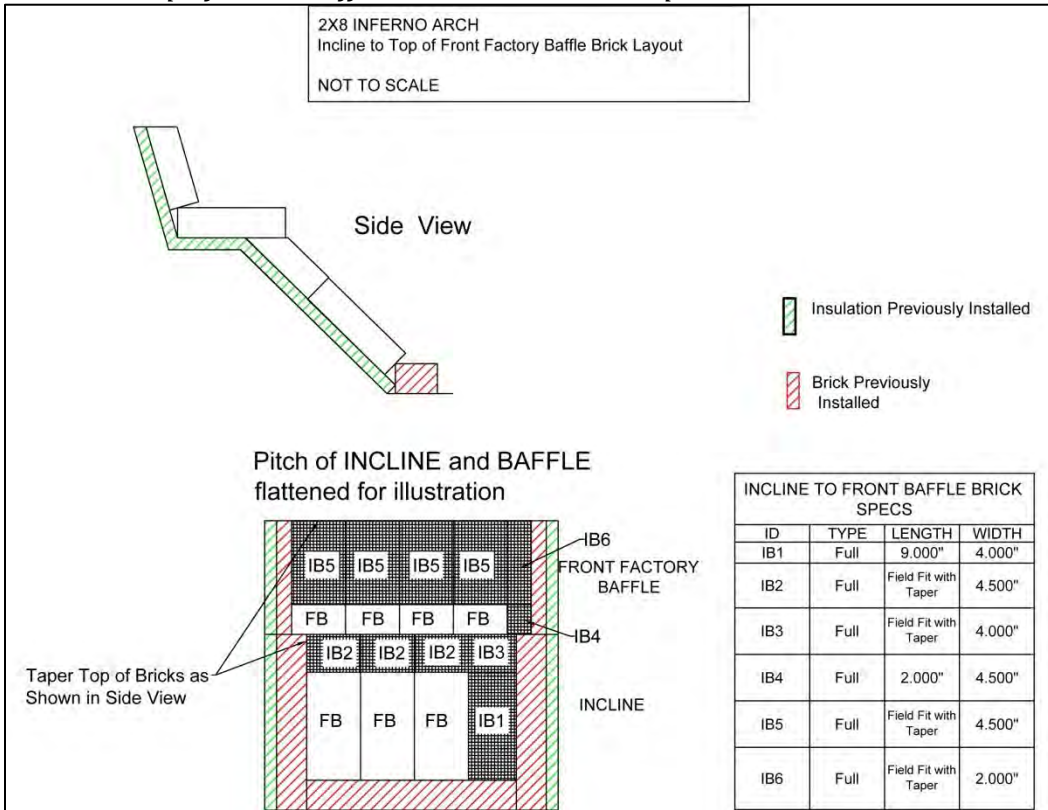

## Behind the Rear Factory Baffle – General Outline

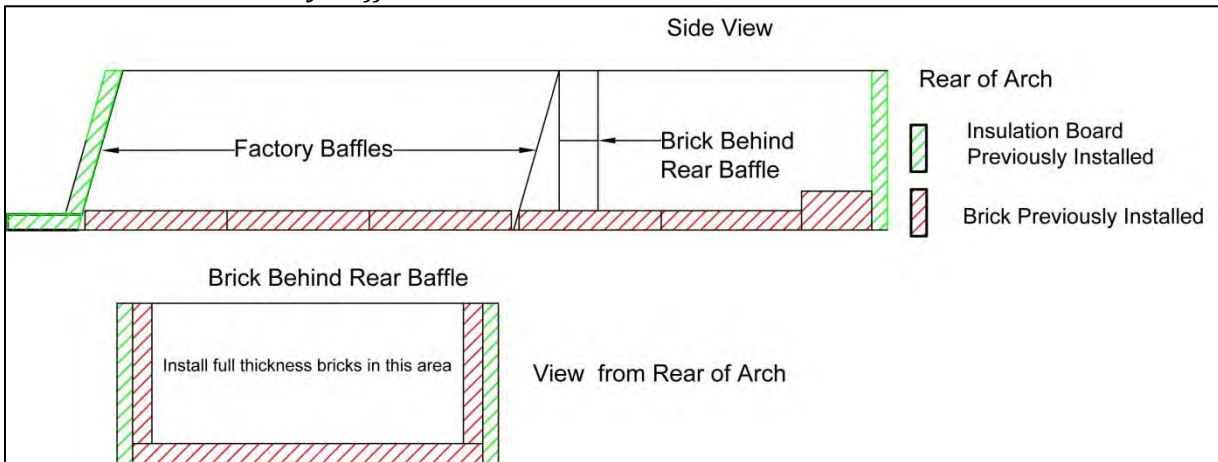

1. Begin by placing a full thickness brick lengthwise on edge on the rear floor of the arch where the rear floor brick meets the side brick. The front of the brick should be in line with the top front edge of the baffle.

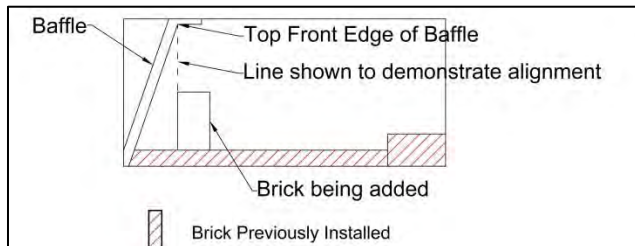

2. Continue the row of bricks until the other side of the arch is reached. Fit the last brick for length.

3. Start a second row of bricks over the end of the previous row completed. In most cases this should result in a staggering of the brick joints. If the row ended in a full brick, cut a brick in half (4 ½" x 4 ½") to start the row.
4. Double check the fit and cement the bricks into place.

*Behind the Rear Factory Baffle – Detailed 2X8 Example*

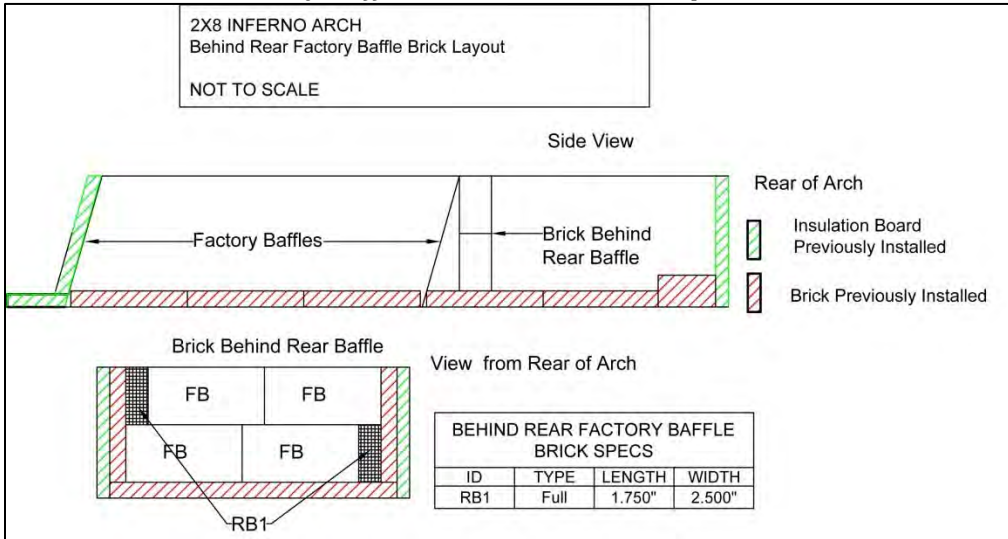

*Baffle Area Completion – General Outline*

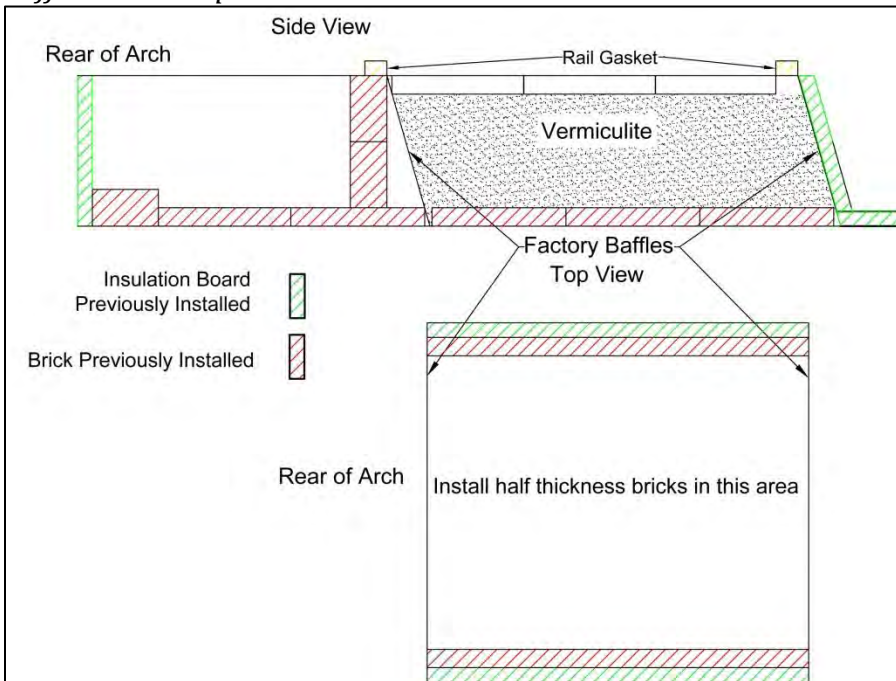

1. The area between the baffles should be filled with vermiculite up to a level of 1 ¼" below the top of the arch rail.
2. Fit half thickness bricks over the surface of the vermiculite and cement the bricks in place.
3. Using refractory cement, attach a layer of 1" rail gasket across the top of the baffles.
4. As an option insulation board can be used in place of the bricks over the Vermiculite. If insulation board is used, fill the Vermiculite area up to 1" below the arch rail. Reduce the number of half bricks by the area over the Vermiculite and increase the number of insulation boards to cover the same area. It is recommended a minimum of piecing be done to prevent movement of the insulation board.

## Baffle Area Completion – Detailed 2X8 Example

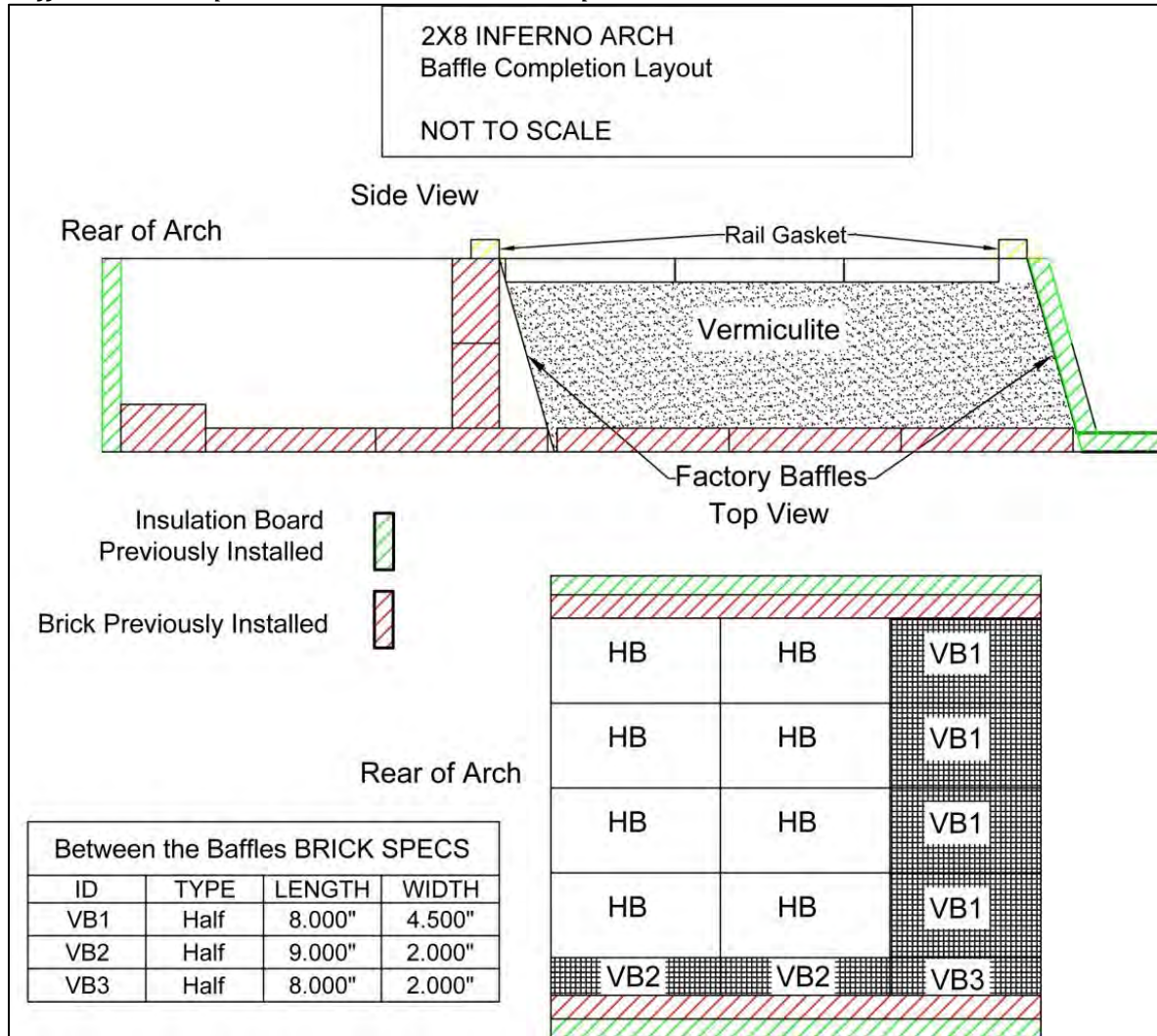

### INSTALL TAPER AND STACK

A roof jack should be installed prior to setting up your taper and stack. Leader Evaporator recommends a water tight roof jack for the evaporator. Leader Evaporator offers two styles of roof jack; water tight or with collar in either a peak or side mount.

In order to determine your requirements you will need to know where you will penetrate the roof with the stack and the pitch of your roof.



## Roof Penetration and the Type of Roof Jack:

- a. Obtain a plumb bob with sufficient line to reach from the roof to the stack collar of the arch.
- b. Run the plumb bob from the center of the stack collar to the roof, moving the roof point until the plumb bob is properly positioned. Ensure there are no bends in the line caused by other items.

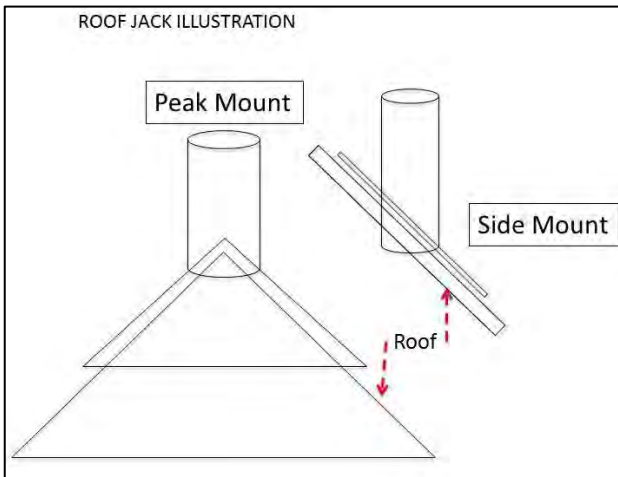

- c. If the plumb bob line end is at the peak of the roof - order a Leader peak mount roof jack. If the plumb bob line end is at the side of the roof - order a Leader side mount roof jack.
- d. Prior to taking down the plumb bob, mark the inside of the roof, as this will be used when making the roof penetration for the stack or installation of the roof jack.
- e. Roof penetration:
  - i. When installing a roof jack refer to the [LEADER CUSTOMIZED ROOF JACK](#) document.
  - ii. If not using a roof jack, make a hole at the point marked on the inside of the roof in the previous step. Mark the roof a minimum of 2" out from and around the template. Refer to the applicable governmental regulations as to minimum clearances required dependent on materials of roof construction.

## Install the Taper and Stack

NOTE: It is recommended you install all supplied exhaust stack, as a minimum. Additional stack may be required to ensure proper draft.

Draft is correct when:

- The boil is the same in the syrup pan front-to-back and side-to-side
- The fire door is open the flame, sparks, etc. are drawn toward the rear of the arch.

NOTE: When working with stack sections, recognize that the crimped end of the stack section is the upper / top section.

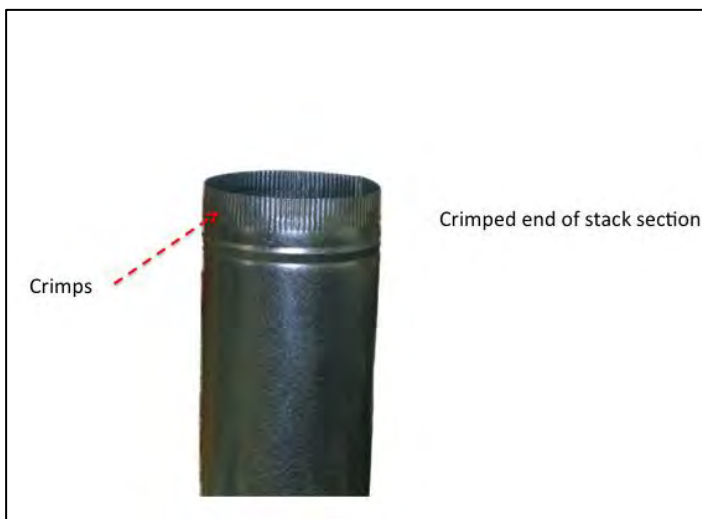



### Base Taper Over Arch Stack Collar

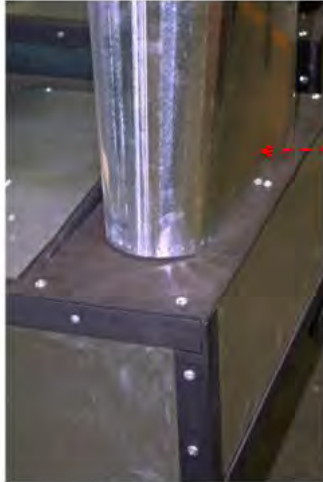

To install, press here on both sides of taper to squeeze the taper. Place the taper over the arch stack collar.

1. Place the base taper on the arch stack collar. If you have difficulty placing the base taper onto the collar, squeeze the base taper by pressing on the long sides at the base.

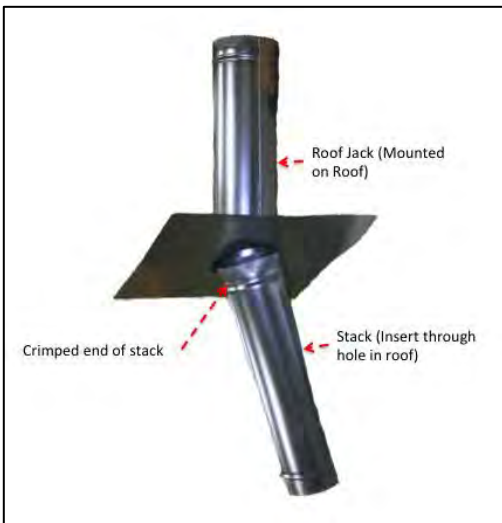

2. If a roof jack is used,

- a. Insert one piece of stack into the roof jack until it is a lightly wedged. The Leader style roof jack is tapered from larger to smaller. The end to be inserted into the roof jack is the crimped end. NOTE: You will be moving the piece of stack back down by approximately 2 1/2" when you connect to the next stack section so ensure it will be able to move.
- b. Measure from the top of the taper to the bead at the bottom of the stack section in the roof jack.
- c. Determine the number of lengths of stack required by dividing the measurement taken in inches by 34".
  - i. For example if the measurement was 68", then  $68" \div 34" = 2$  so 2 lengths of stack are required.
  - ii. For example if the measurement was 60", then  $60" \div 34" = 1.76$  lengths of stack are required. This would mean one full length and a length measuring 26" would be required. To obtain the 26" length you can either
  - iii. Special order a piece of stack the length required or cut a standard length of stack to fit. If you cut a length of stack to fit, measure the length from the bead of the stack and cut off the top crimped end.

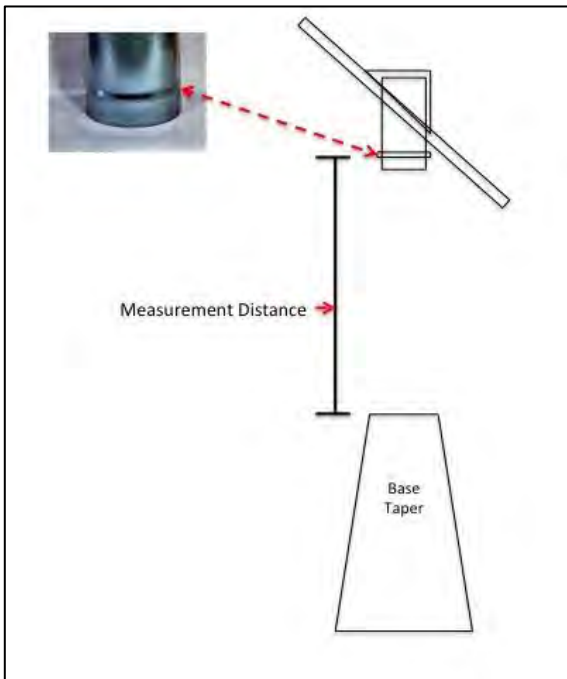

3. Install the stack sections starting from the base taper. Ensure you place the crimped end up when connecting the stack sections.
4. When you put the last indoor section in place, lower the stack section from the roof jack (if used) approximately 2 ½” down onto the top piece of stack, or lower a stack section through the penetration in the roof.
5. If a roof jack is used, use all remaining sections of stack by placing the beaded / bottom end over the top of the roof jack.
6. Continue installing stack until all pieces have been installed. Ensure you have a good overlap for each stack joint. Overlap will be 2 to 2 ½”. It is recommended you screw all sections together using self tapping stainless steel screws.
7. Stack above the roof should be guide wired in at least three directions (tripod configuration) to minimize the effects of wind.
  - a. It is recommended you install a stack cover on the last / top section of stack. A closed stack cover will minimize the rain and moisture entering the stack and arch. When installing a stack cover refer to the [LEADER STACK COVER](#) document.

## **THE FIRST BOIL**

The first boil is done to remove any residual materials from the pans and to “season” the bricking and insulation.

1. Fill the flue pan and syrup pan with a baking soda : water mix (1 pound:200 gallons) to a level of 2 to 3 inches.
2. Check all fittings for leakage. If there is no leakage, insulate around the flue drain with rail gasket material.
3. To season the bricking, start by building a small fire in the fire box and very gradually build to a normal fire.
4. Boil the solution for approximately 30 minutes. Watch the boil carefully and replenish the solution as needed to ensure the solution in the pans remains at the 2 to 3 inch level.
5. Check all equipment:
  - a. No leaks at connections and valves
  - b. Pans are boiling evenly
  - c. Valves work properly
  - d. Draft is correct
6. Drain the solution after the evaporator has cooled. CAUTION – ensure the equipment is cool enough to be safely handled for draining.
7. Check the interior of the arch to ensure insulation and bricking are in place.
8. Refill the pans to the 2 to 3 inch level with clean unsoftened, non chlorinated well or spring water.
9. Boil for 30 minutes then after the evaporator has cooled, drain the pans. CAUTION – ensure the equipment is cool enough to be safely handled for draining.

## **OPERATING THE EVAPORATOR**

NOTE: When operating the evaporator be cautious of hazards such as hot surfaces, hot liquids, sparks, and exposed flames.

NOTE: You must be aware at all times of the level of sap in all compartments of the pans. If the level drops too low you can and will damage your pans. If there is too much foam you risk damaging your pans.

NOTE: If you have purchased a scoop or skimmer, do NOT use them to push sap through the evaporator. Doing so will change the gradient in the evaporator.

1. Check the evaporator
  - a. Make sure all sap sources are flowing freely i.e. not frozen.

- b. Open hood thimbles and drains, cupolas and stack covers.
  - c. Ensure defoamer is usable.
  - d. Ensure all fittings are tight.
  - e. Make sure all valves are working properly and the float is properly positioned.
  - f. Clean the flues with the flue brush every 8 to 12 hours of boiling. NOTE: The rod supplied with the arch has a threaded end. The flue brush can be screwed onto the rod to clean the flues.
  - g. Ensure the open area in the grates is clean and free of material
  - h. Remove the ashes from below the grates.
2. The arch should be fired with a mixture of hard and soft wood.
  3. The wood to be used should be dry and cut to length so as to fit on the grates in the arch.
  4. The wood to be used should be split to the size as shown for the arch in the following table.

EVAPORATOR WIDTH (inches)	SPLIT WOOD (inches)
24	2 to 3
30	2 to 4
36	2 to 4
40	2 to 5
48	2 to 5
60	3 to 6
72	3 to 6

5. Guidelines for firing the arch:
  - a. Criss cross the wood for improved air flow
  - b. Turn the blower down (not OFF) to fire
  - c. Maintain a 150°F range of stack temperature
  - d. Fire consistently to maintain an even boil – use of a timer will aid in keeping to a schedule
  - e. Maintain the arch  $\frac{1}{2}$  to  $\frac{2}{3}$  full

## BLOWER USE

Prior to using the blower it must be adjusted to the rheostat as follows:

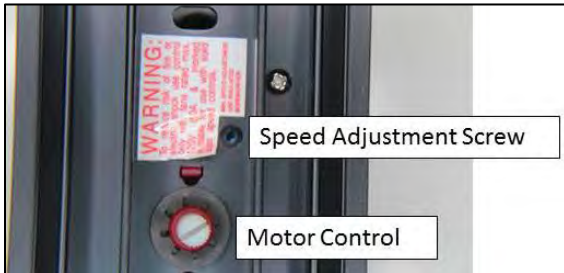

1. Turn the Motor Control clockwise as far as it will go.
2. With a fine straight bladed screwdriver, turn the Speed Adjustment Screw until the blower is just turning.
3. Turn the Motor Control counter clockwise until it reaches the maximum setting. The blower should be running at maximum.

- Turn the blower all the way down to fire the arch. Do NOT turn it off as it cools the grates.
- When adjusting during boiling, set the blower so the stack temperature is between 900°F and 1000°F.

## DAILY SHUTDOWN

1. There are two factors influencing the shutdown of the evaporator; time and sap volume.
  - a. It will require approximately 30 minutes to 1 hour from the last firing to bring the fire down to embers (coals on the grates) in a wood fired arch.
  - b. It will require a volume of sap from the last firing to embers and to flood the arch so ensure there is adequate volume left prior to the last firing.
2. Continue to monitor the arch as done for normal operations.
3. When there is no more boil in either the flue or the syrup pans and the fire is down to coals on the grates (in a wood fired arch), add sap until the pans are at a depth of 2". This is done by holding the float down or by adjusting the float handles and lowering it. If the sap remaining does not cover the pans to the 2" depth then add clean, unsoftened, non-chlorinated well or spring water until the depth is reached.

NOTE: The extra sap depth is required as the insulation of the arch (ex. bricks) will hold heat and continue the evaporation process until the heat has been dissipated.

## **MAINTENANCE**

NOTE – prior to performing maintenance make sure the surfaces have been cooled.

### **DAILY**

1. Remove spills and splashes from the pans by wiping with hot water.
2. Clean the grates
3. Check all fittings for leakage. Repair / replace as necessary.

### **PERIODIC**

1. Using the supplied brush and rod, brush the underside of the flue pan to remove accumulated material. Cleaning will allow the heat to better reach the sap in the pan.
2. Inspect the rail gasket and pan gasket for areas where heat and smoke maybe escaping. Replace if necessary.
3. Clean out the ash chamber.

### **END OF SEASON**

1. Discard the rail gasket and pan gasket.
2. Inspect all arch insulating materials (brick, insulating board, blanket). Replace if missing or damaged.
3. Clean the grates.
4. Raise the flue pan out of the arch and finish draining.
5. Thoroughly brush the soot from the flues of the flue pan.
6. Set 2X4s across the rail of the arch where the flue pan is usually placed then set the flue pan right side up on the 2X4s.
7. Set 2X4s across the rail of the arch where the syrup pan is usually placed then set the syrup pan right side up on the 2X4s.
8. Cover the pans and arch with plastic, a tarp or hoods.

### **BEGINNING OF SEASON STARTUP**

1. Remove the cover and take the pans and 2X4s off from the arch.
2. Install a new rail gasket.
3. Place the pans on the arch and install a new pan gasket between the pans.
4. When filling the pans for the first time, check all fittings for leakage and repair if necessary.

### **FEEDBACK**

Please use the following e-mail address ([feedback@leaderevaporator.com](mailto:feedback@leaderevaporator.com)) to suggest improvements or enter comments on this document. Reference the document title in your note. You may also contact LEADER Customer Service.

### **NOTES**