

**S
P
R
I
N
G
T
E
C
H**



Extreme

Built By: Leader Evaporator Co., Inc.

EXTREME 1 Reverse Osmosis System



Leader Evaporator Co., Inc.

49 Jonergin Drive

Swanton, VT 05488

Tel: 802-868-5444

www.leaderevaporator.com

TABLE OF CONTENTS

INTRODUCTION	4
THEORY OF OPERATION.....	4
<i>Terms.....</i>	4
<i>Description of Membrane.....</i>	5
EQUIPMENT DESCRIPTION.....	6
FRONT VIEW.....	6
REAR VIEW.....	7
FEED PUMP.....	7
PRESSURE GAUGES	7
RECIRCULATION AND PRESSURE PUMPS	8
PREFILTER ASSEMBLY AND WASH TANK	8
SAMPLING PORTS	8
CONTROL PANEL	9
FLOW METERS.....	9
V1 AND V2 VALVES	9
FLOW CONTROL VALVES	10
INCLUDED EQUIPMENT	11
OPTIONAL SETUP EQUIPMENT, PARTS AND SUPPLIES.....	11
SETUP	12
AREA REQUIRED	12
POWER REQUIREMENTS.....	12
GENERAL CONNECTION LAYOUT	13
<i>SIMPLE 3 TANK R/O DIAGRAM</i>	14
STRAINER CONNECTIONS.....	14
V6 CONNECTION	15
WD CONNECTION	15
VESSEL AND PUMP DRAINS.....	16
V3, V4 AND V19 CONNECTIONS	17
<i>V19 – Connection To Drain</i>	17
<i>V3 – Connection To Permeate Storage.....</i>	18
<i>V4 – Connection To Concentrate Storage.....</i>	18
OPERATION	19
STARTUP OF SYSTEM WITH LITTLE OR NO FLUID.....	19
INITIAL SYSTEM CLEANING.....	19
DATA LOGGING	20
CYCLES AND TIMING.....	20
PERMEABILITY TEST.....	21
FLOW VALVE INFORMATION	23
ADJUSTING V1 AND V2 FOR OPERATIONS	23
SAMPLE PORT USE.....	24
CONCENTRATE CYCLE	24
DESUGAR CYCLE	27
RINSE CYCLE	29
WASH CYCLE	32
<i>Hot Water Wash.....</i>	32
<i>Alkaline Soap Wash.....</i>	32
<i>Intensive Alkaline Soap Wash.....</i>	32

Acid Soak 32

MAINTENANCE **35**

PRE FILTERS 35

MEMBRANE REMOVAL AND INSTALLATION 36

Removal 36

Installation 38

DAILY 40

PERIODIC 41

END OF SEASON SHUTDOWN AND STORAGE 41

BEGINNING OF SEASON STARTUP 42

TROUBLESHOOTING CHART **43**

ATTACHMENT #1 – ELECTRICAL SCHEMATIC **44**

ATTACHMENT #2 – OPERATIONS DATA LOGSHEET **49**

ATTACHMENT #3 – WARRANTY INFORMATION **52**

INTRODUCTION

A Leader Evaporator Springtech EXTREME Reverse Osmosis system is designed to significantly improve the producer's productivity by generating higher sugar percentage sap. Through use of high pressure, the system removes water from the sap resulting in a more concentrated sugar solution entering the evaporator. This in turn shortens the boil time required resulting in fuel and time savings.

Some of the features of the Springtech EXTREME 1 are:

- Easy accessibility to pumps and membranes
- Stainless steel frame, membrane housing, pressure and recirculation pumps
- Fast wash cycle
- With reasonable sap – the ability to generate 6% to 10% brix concentrate with a single pass
- Flow meters for the permeate of each membrane and one for the system concentrate

THEORY OF OPERATION

In reverse osmosis, through the use of special semi-permeable membranes and high pressure, water is forced, in a pure form, through the membrane while the concentrated solution remains outside the membrane and is concentrated. For the sugar maker this means water (permeate) is removed from the sap and a sap with a higher sugar level (concentrate) is produced for the evaporation process.

Terms

Semi-permeable Membrane – Unit consisting of multi layers of spacers and membranes

Pre-Filter Unit – Designed to remove suspended solids from the sap incoming to the reverse osmosis system

Feed Pump – The initial pump designed to supply the reverse osmosis unit with sap and maintain pressure in the system

Pressure Pump – The pump designed to provide the pressure needed to force the sap through the reverse osmosis membrane

Pressure Vessel – The containment unit for the semi-permeable membrane

Permeate – Purified water removed from the maple sap during the concentrate cycle

Concentrate – the maple sap having a higher percentage of sugar because water (permeate) has been removed

Permeate Holding Tank – A tank designed to hold a minimum twice the hourly output of the system

Concentrate Cycle – Process during which water is removed from maple sap resulting in Concentrate and Permeate

De-Sugaring Cycle - Process to reclaim sugars from the membrane during which Permeate is run through the reverse osmosis unit using Concentrate cycle valve settings

Rinse Cycle – Cleaning process of passing stored Permeate through the Reverse Osmosis system and out to drain

Chemical Wash Cycle – Process of chemical washing the membranes by recirculating a solution through the reverse osmosis system. Dependent on requirement, chemical maybe be alkali or acid.

Permeability Test – Test to determine the performance of the membranes against a benchmark

Sap Concentration Loop – Process of recirculating output from the concentrate cycle to the raw sap tank, increasing the concentration of the sap in the tank

Description of Membrane

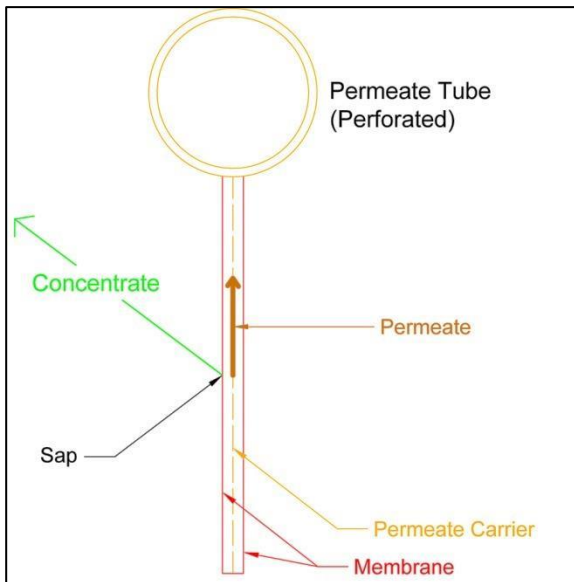

The basic units of the reverse osmosis membrane are described in the *cross section* drawing.

- Attached to the permeate tube is a membrane unit consisting of a permeate carrier between two membranes.
- There are a number of these membrane units attached around the outside of the permeate tube.
- Between each of the membrane units is a spacer through which the sap and concentrate can flow.
- The permeate tube is perforated so the permeate can be collected from the membrane unit.
- At each unit as the sap is pressurized, the permeate can flow through the membrane and be carried to the permeate tube. The concentrate cannot penetrate the membrane and is pushed out the membrane assembly.
- The membrane units are wound around the permeate tube and an outside support structure is placed around the wound assembly.

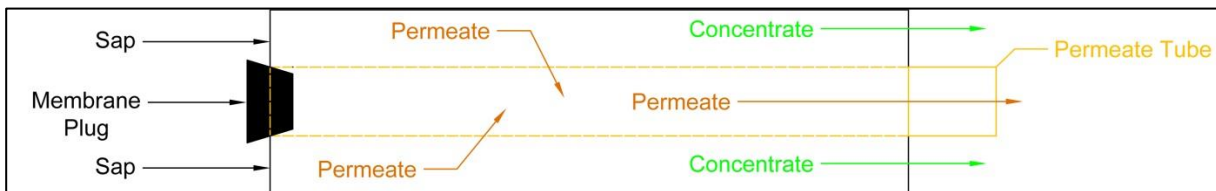

The drawing above represents the flow of liquid through a membrane in the system. The membrane is housed in a pressure vessel (not shown).

EQUIPMENT DESCRIPTION

The LEADER EVAPORATOR Springtech EXTREME Reverse Osmosis System is designed to offer maximum concentration to cost performance. Through optimizing of pumps and membranes the reverse osmosis systems deliver greater flow potential to the user. The LEADER EVAPORATOR Springtech EXTREME Reverse Osmosis system is designed and built using the same principles of superior quality applied to our evaporators.

The LEADER EVAPORATOR Springtech EXTREME Reverse Osmosis System is covered by a manufacturer's warranty – See ATTACHMENT #3.

NOTES:

1. Pictures, sketches and drawings presented in this document are not to scale.
2. Directions (right and left) will be as facing the front of the system.

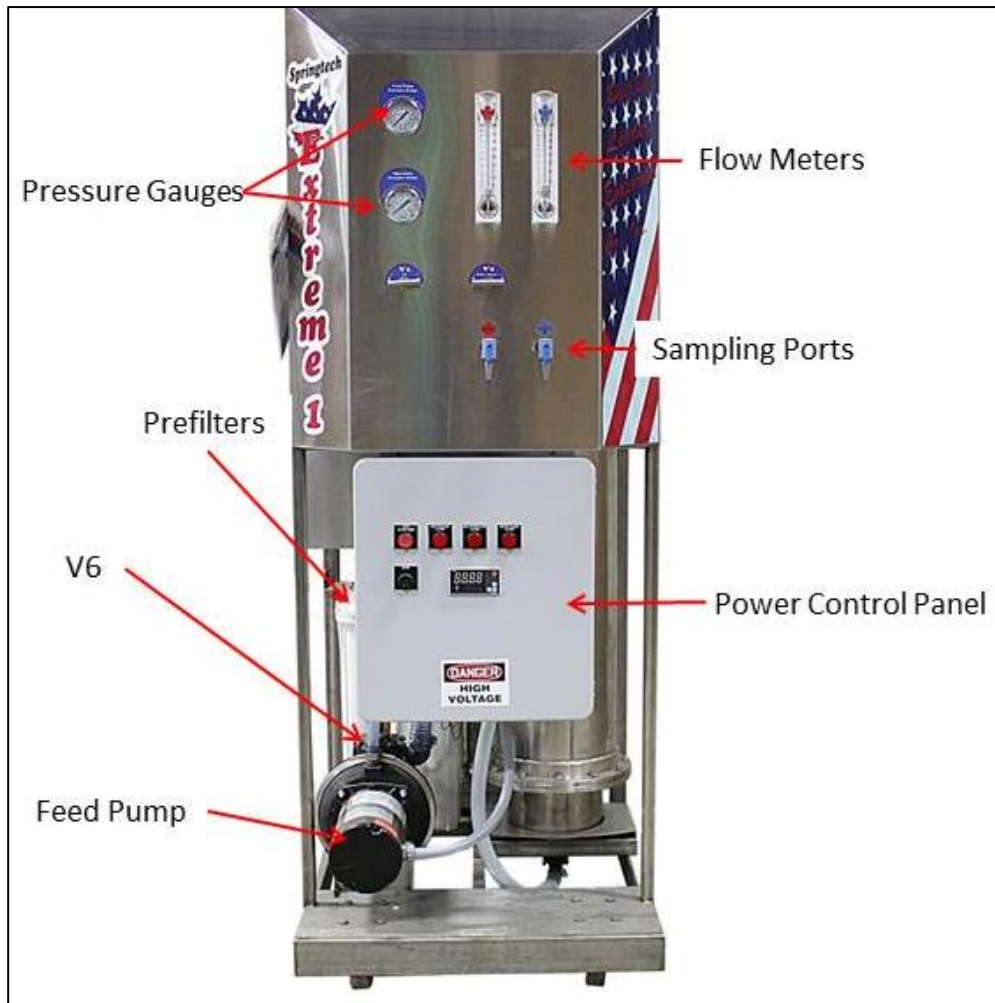

Front View

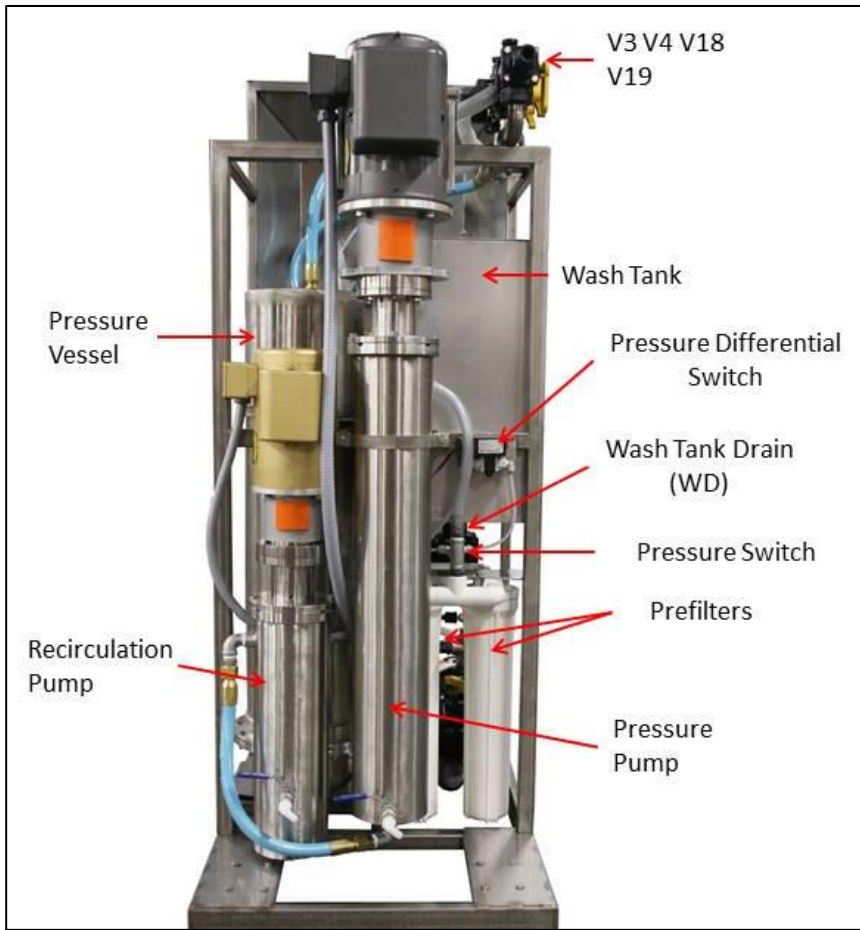

Rear View

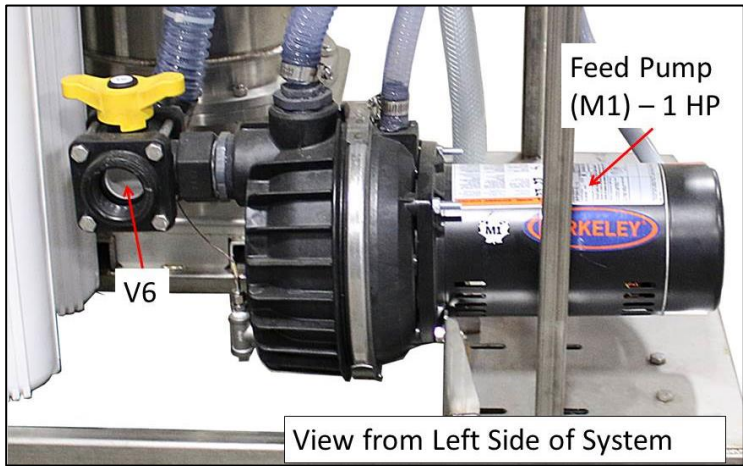

Feed Pump
Provides liquid to the system and is the first stage of pressurizing the system

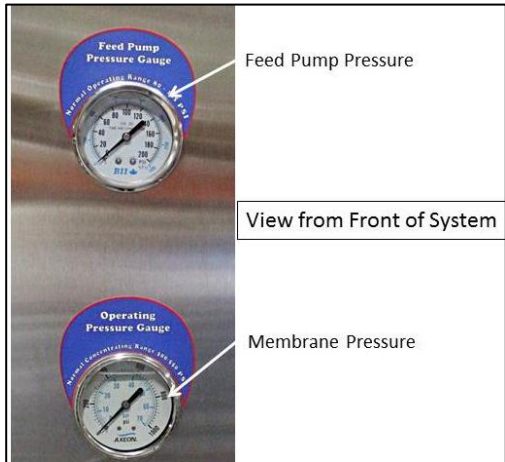

Pressure Gauges
Feed pump pressure is read after the prefilters.
Membrane pressure is read after the last membrane.
WARNING: DO NOT ALLOW THE OPERATING PRESSURE TO EXCEED 550 psi.

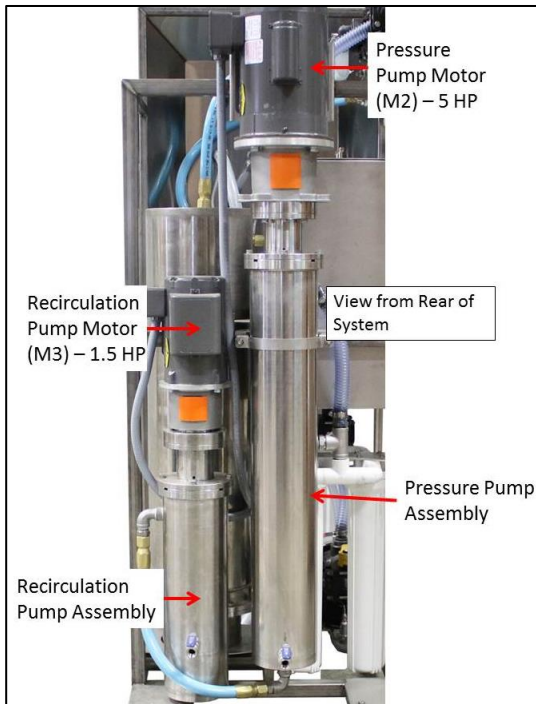

Recirculation and Pressure Pumps

Pressure Pump - Second stage of pressurizing the system required to process the sap through the membranes.

Recirculation Pump - Recirculates liquid within the vessel to which they are attached.

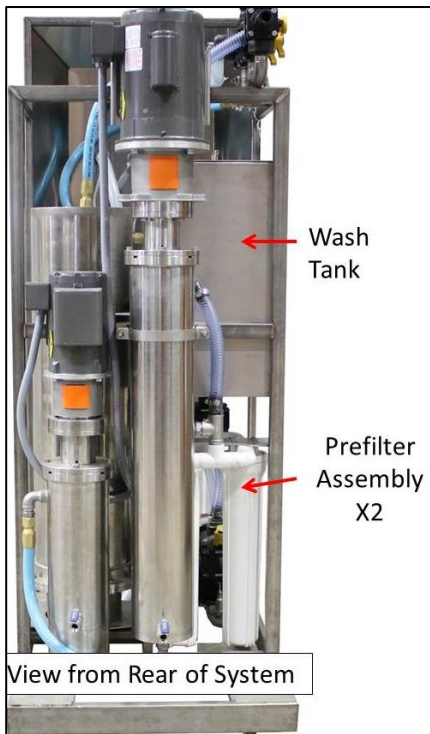

Prefilter Assembly and Wash Tank

Prefilter assembly requires (2) - 20" cartridge filters

Wash tank is used to mix the chemical solution for cleaning the system.

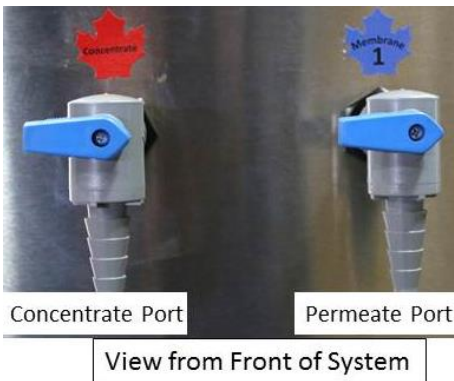

Sampling Ports

Concentrate port is used to sample the liquid concentrate to determine the sugar percentage.

The Permeate port is used to sample the permeate from the membrane to determine if it is allowing sugar to pass through.

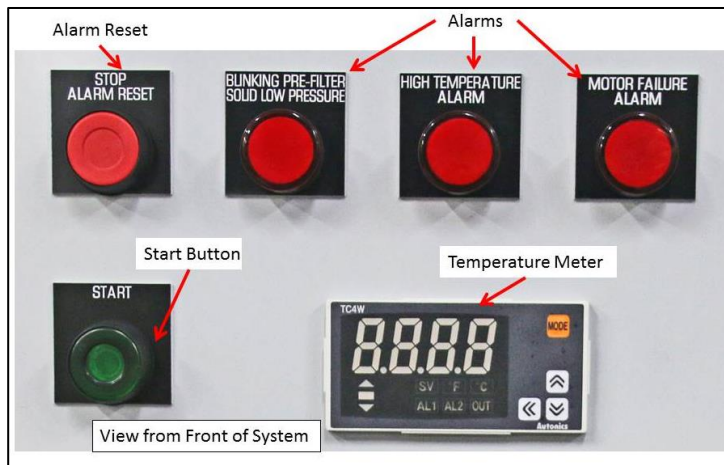

Control Panel

Start button when pressed starts the system pumps in sequence.

The STOP or STOP / ALARM RESET button is a master reset for all the alarms and will stop the machine when pressed.

The Temperature Meter indicates the temperature of the liquid flowing through the system.

Pressure Alarm indicates a pressure condition in the system related to the pressure pump requirements. The alarm light may be solid (low pressure) or blinking (prefilter). This alarm can be part of normal operations. The machine will shut down when the indicator light is activated.

High Temperature Alarm indicates the Wash cycle has completed. This alarm is part of normal operations. The machine will shut down when the alarm light is on.

Motor Failure Alarm is due a motor contactor tripping. Contact Leader Evaporator Technical Service.

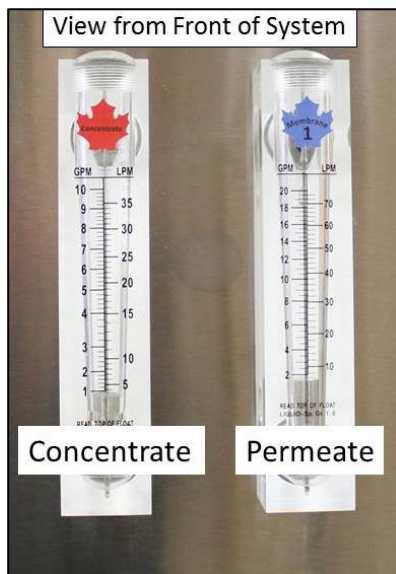

Flow Meters

The Concentrate Meter indicates the liquid flow from the concentrate side of the pressure vessel in gallons per minute.

The Permeate Meter indicates the permeate flow from the membrane in gallons per minute.

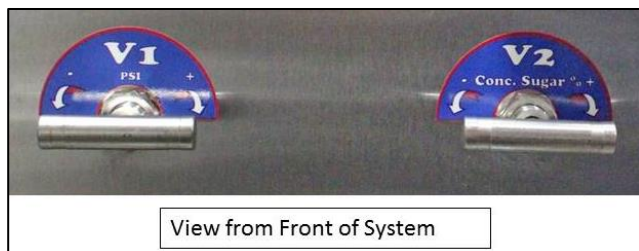

V1 and V2 Valves

V1 controls the pressure to the membranes. It is opened ½ way when starting then adjusted to reach the pressure wanted. Close V1 to raise the pressure in the system.

V2 controls the flow from the concentrate side of the membranes. It is opened ½ way when starting then adjusted to the desired concentration level.

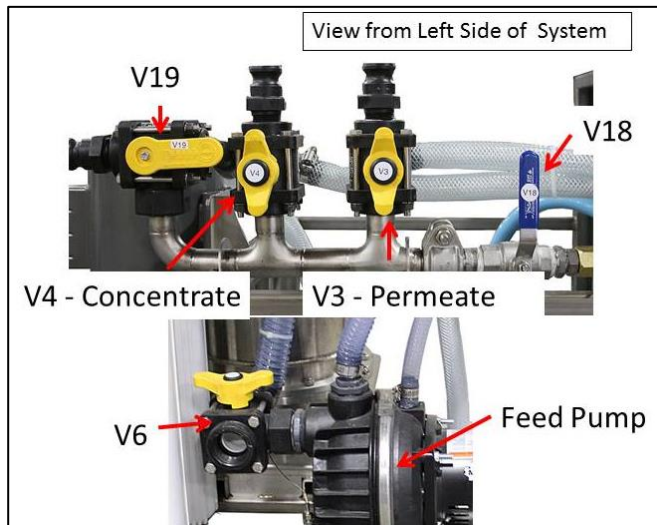

Flow Control Valves

These valves control the flow of liquid through the system

V3 – Permeate flow

V4 – Concentrate flow

V6 – Feed flow



V18 – Cleaning or Concentrate flow



V19 – Drain or Wash Tank

VALVE	TYPE	SET POSITION	LIQUID FROM - TO	SET POSITION	LIQUID FROM-TO
V3	3 - Way	HANDLE POINTING UP	Membrane to Permeate out	HANDLE POINTING DOWN	Membrane to Valve V19
V4	3 - Way	HANDLE POINTING UP	Membrane to Concentrate out	HANDLE POINTING DOWN	Membrane to Valve V19
V6	3 - Way	HANDLE POINTING TOWARD PUMP	External to Feed Pump	HANDLE POINTING TOWARD WASH TANK PIPE	Wash Tank to Feed Pump
V18	2 - Way	HANDLE POINTING UP	No Flow	HANDLE POINTING HORIZONTAL	Membrane to Valve V19
V19	3 - Way	HANDLE POINTING DOWN	Membrane to Drain	HANDLE POINTING HORIZONTAL	Membrane to Wash Tank
WD	3 - Way	HANDLE POINTING UP	Recirculation to feed pump	HANDLE POINTING HORIZONTAL	Drain Wash Tank







The Leader Springtech EXTREME Reverse Osmosis system consists of the following parts:

Included Equipment

ITEM	LEADER ORDER #	DESCRIPTION / PHOTO
Springtech EXTREME 1	700018	
Springtech EXTREME 1 User Manual		
1" Quick Coupler C Qty: 3	47148	

ITEM	LEADER ORDER #	DESCRIPTION / PHOTO
Strainer Y 1-1/2" modified with bleeder valve		
Springtech EXTREME 1 Quick Start Guide		

Optional Setup Equipment, Parts and Supplies

ITEM	LEADER ORDER #	DESCRIPTION / PHOTO
Membrane Preservative, 1 lb.	70001	
Citric Acid, 1 lb.	70008	
20" Cartridge Filter	70012	
12" Sap Hydrometer	61061	
Digital Refractometer	61058	
2 to 20 GPM Flow Meter		
pH Meter	61060	

ITEM	LEADER ORDER #	DESCRIPTION / PHOTO
RO Soap 5 Lbs.	69992	
Glycol, 1 gal.	70009	
Food Grade Grease	55095	
Long 2" Diameter Test Cup	59006	
Sap Refractometer	61073	
0 to 10 GPM Flow Meter		
pH Meter Replacement Probe	61060P	

SETUP

NOTES:

- All materials used should be approved for potable water. No copper should be used.
- When installing plumbing for the system, factor in the system may need to be moved for such items as maintenance. It is recommended the connections be made with fittings such as quick disconnects.
- All feed piping to the Springtech system must be at least as large as the feed on the system itself – 1 – ½” is recommended
- All installations must meet applicable governmental regulations.

Area Required

The space to be used should be capable of preventing the RO system from freezing. Additionally it will need to have adequate ventilation during operations to prevent overheating.

The dimensions of the unit are

- Width – 28”
- Length – 48”
- Height – 77”

A minimum of two feet around the system is recommended. You must also be able to obtain an additional area in order to remove membranes and pump assemblies.

The room should have adequate drainage. The walls, ceiling and floor should be easy to clean.

Power Requirements

The system requires 220V / 1 Phase, 38 amps. All electrical work should be done by a licensed electrician and meet all local codes.

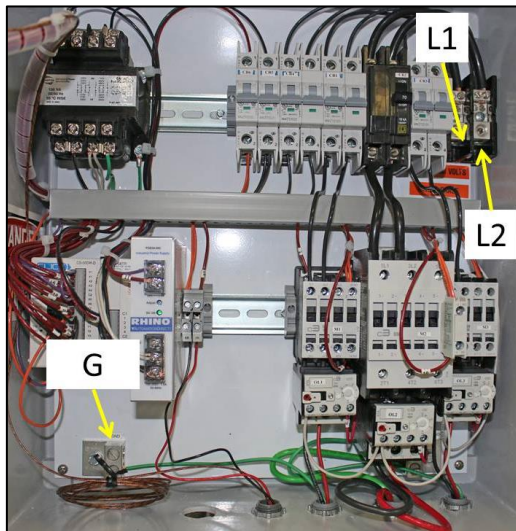

MOTOR ID	MOTOR FUNCTION	SIZE (HP)	NAMEPLATE AMPERAGE
M1	Feed Pump	1	6
M2	Pressure Pump	5	23
M3	Recirculation Pump	1.5	7

NOTE: Any time the control panel is opened, the power should be turned off at the source.

Electrical Schematics

Use the following guidelines to determine which electrical schematic is applicable to the RO system.

- Determine if the RO system has a pressure differential switch. Reference the Rear View picture found on page 7.

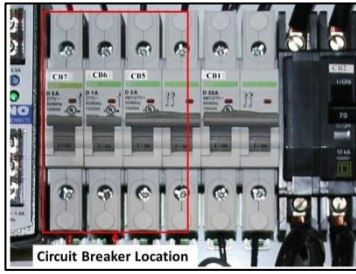

- Identify the labelling of the last three breakers of the breaker block and verify the amperage.

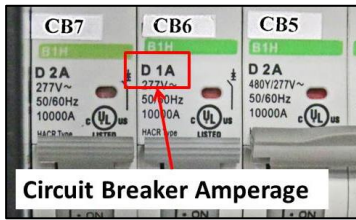

- Identify the amperage of the breakers. They should be in order; 2 amps, 1 amp, 2 amps.

Breaker Labels	Pressure Differential Switch	Schematic	Schematic Corrections
4, 5, 6	No	ATTACHMENT 1A	
4, 5, 6	Yes	ATTACHMENT 1B	
5, 6, 7	No	ATTACHMENT 1A	CB7 should be 2A CB4 should be 20A for Optional Extension Kit
5, 6, 7	Yes	ATTACHMENT 1C	

General Connection Layout

The following illustrates a generalized layout for connections with the Springtech EXTREME RO System. The first drawing shows tank connections to the system. The second drawing shows an arrangement of valves to connect the incoming liquid to the system. Dependent on the location, other arrangements are likely. It is beyond the scope of this document to recommend the best layout for all situations. It is recommended you contact your LEADER EVAPORATOR sales person or your local Distributor / Dealer for assistance in deciding the correct tanks and layout for your needs.

SIMPLE 3 TANK R/O DIAGRAM

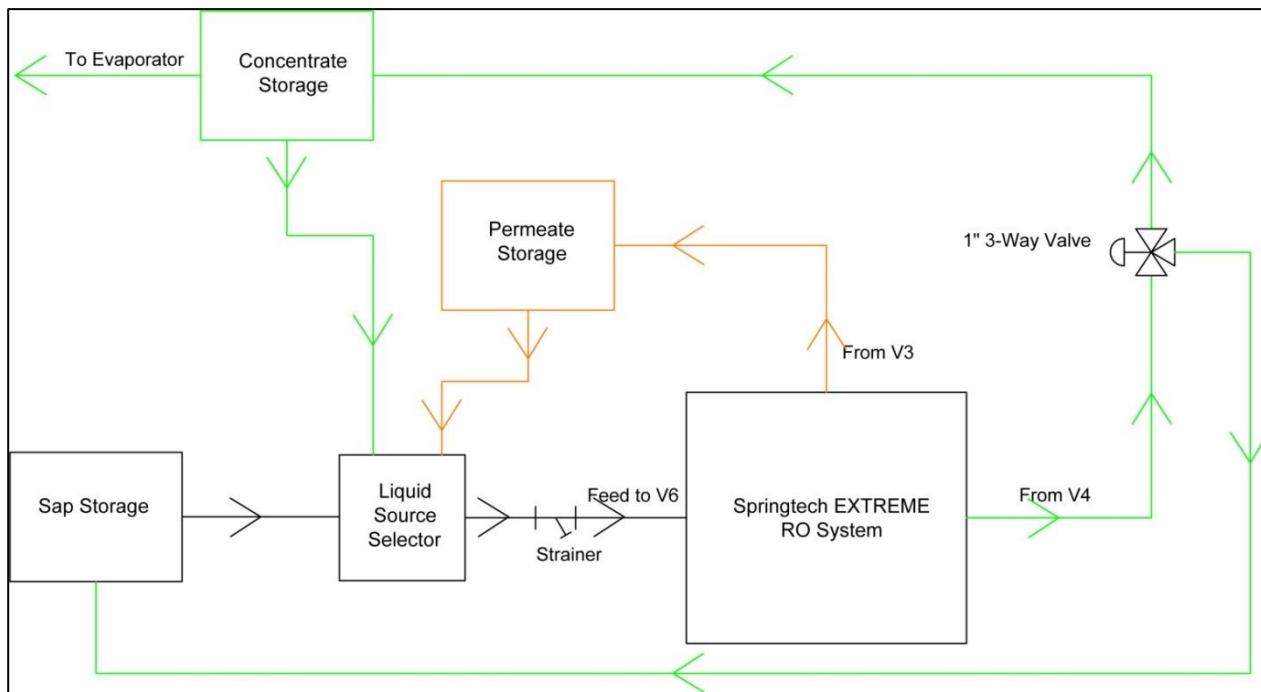

Liquid Source Selector

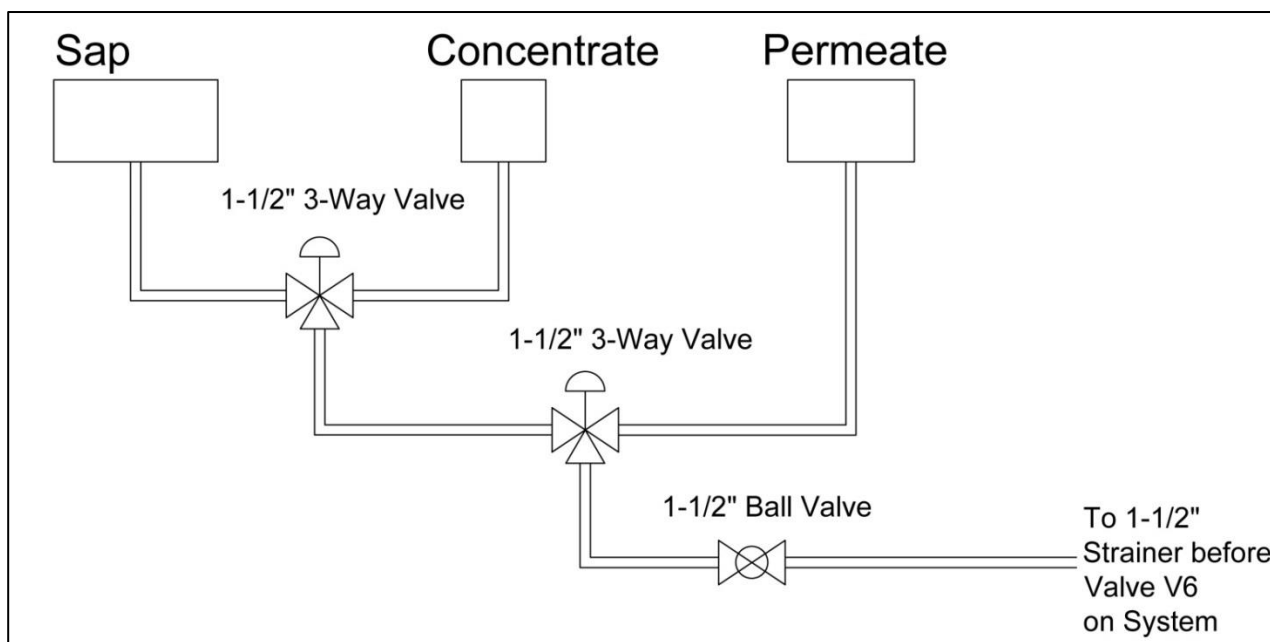

Valves should be in the R/O room for ease of operation. Additional valves and tanks may be required depending upon installation.

Strainer Connections

Plumbing from the supply tanks is recommended to be 1 – ½” ID. The strainer is not mounted to the system. It will need to be mounted by the user. The connection can be made as follows:

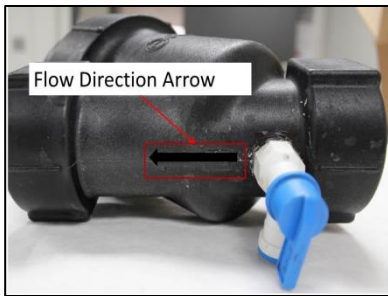

1. Identify the flow direction through the strainer,. There is an arrow on top of the strainer which shows the direction of flow. The input side pushes the liquid through the strainer prior to it going into the system. Additionally, when mounting the strainer, the spigot should be on top as it will need to be opened to bleed air from the system,
2. Install a valve before the Y strainer so the strainer can be removed and cleaned.

V6 Connection

The V6 valve is to be setup so the connection can be easily disconnected and reconnected as necessary. The following is the recommended connection detail.



1. Teflon tape a 1 ½" F style quick coupler.



2. Thread the F style quick coupler into valve V6. Tighten the coupler. NOTE: Secure valve V6 so as not to break it when tightening the coupler.
3. Obtain a length of 1 ½" braided hose that will connect to the strainer output on the incoming liquid source.
4. Slide a 1 ½" stainless steel band clamp over one end of the hose.
5. Slide the hose onto a 1 ½" C style quick coupler and tighten the clamp over the coupler. NOTE: For demonstration purposes the picture does not show the hose fully slid onto the quick coupler.
6. Pull the metal latches on the quick coupler out to the sides (perpendicular to the body of the quick coupler) then slide the open end of the coupler over the F style coupler on valve V6.
7. Raise the metal latches on the quick coupler back to the side of the C quick coupler while pressing the couplers together.



WD Connection

The WD valve is to be setup so the connection can be easily disconnected and reconnected as necessary. It is the connection from the wash tank to drain. The following is the recommended connection detail.



1. Teflon tape a 1 ½" F style quick coupler.



2. Thread the F style quick coupler into valve WD under the wash tank (and slightly behind the control panel). Tighten the coupler.
3. Obtain a length of 1 ½" braided hose that will connect to the drain.
4. Slide a 1 ½" stainless steel band clamp over one end of the hose.
5. Slide the hose onto a 1 ½" C style quick coupler and tighten the clamp over the coupler.
6. Pull the metal latches on the quick coupler out to the sides (perpendicular to the body of the quick coupler) then slide the open end of the coupler over the F style coupler on valve WD.
7. Pull the metal latches on the quick coupler back to the side of the C quick coupler while pressing the couplers together.

Vessel and Pump Drains

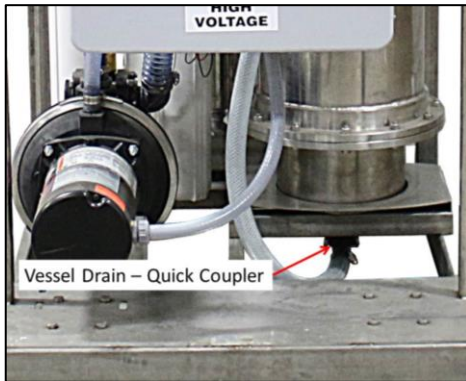

The membrane housing drain is located under the housing. It is a quick disconnect.

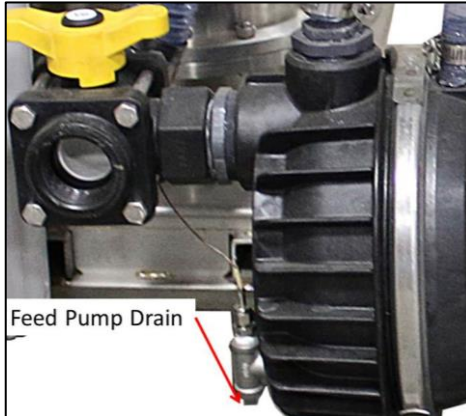

The feed pump drain is a ¼" stainless steel plug located on the front of the pump housing at the bottom of the tee where the temperature sensor is mounted.

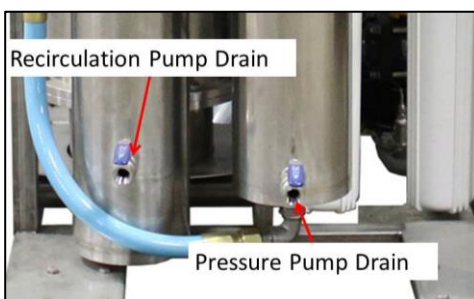

The recirculation and pressure pump drains are provided with a ½" stainless steel ball valve. It is recommended the drains be setup to collect the liquid. The connections on the system for the drain will need (items sold separately);

- 2 – ½" PVC adapters
- 2 – ½" Stainless Steel band clamps
- 2 pieces of ½" hose long enough to connect to the drain adapter and to reach the collection point

An additional drain, the wash tank overflow drain can be connected using a 1 – ½” combo elbow adapter (items sold separately).

Install drain connections as follows:



1. Teflon tape the ½” PVC adapter.



2. Thread the PVC adapter into the stainless steel ball valve.



3. Cut ½” ID braided hose to length (to reach from the ball valve to the point where you will be collecting the liquid). Place a ½” stainless steel band clamp over one end of the hose. Slide the hose onto the PVC adapter. Position the stainless steel band clamp over the hose on the adapter and tighten the band clamp.

V3, V4 and V19 Connections

V3, V4 and V19 valves are to be setup so the connections can be easily disconnected and reconnected as necessary. The following is the recommended connection detail.

In order to assemble the connections you will need (braided hose and clamps sold separately);

- 3 – C style Quick Couplers (supplied)
- 3 (minimum) – 1” Stainless Steel Band clamps
- 1” ID braided food grade hose with length to make the connections for the Permeate and Concentrate tank. The connection to the drain can be made with flexible hose.

V19 – Connection To Drain



1. Cut 1” ID flexible hose to reach from the valve V19 to the drain connection.
2. Place at least one 1” stainless steel band clamp over one end of the hose.
3. Slide the hose onto the 1” C style quick coupler.
4. Position the stainless steel band clamp(s) over the hose on the coupler and tighten the band clamp(s).
5. Secure the other end of the hose to the drain connection. Connect the quick couplers by opening the latches on the C style coupler (position the metal latch arms out perpendicular to the body of the coupler) then sliding the C coupler into the F coupler. Pull the metal latch arms back down to the sides of the C coupler.

V3 – Connection To Permeate Storage



1. Cut 1" ID braided hose to length – from valve V3 to the fill connection for the permeate tank.
2. Place at least one 1" stainless steel band clamp over one end of the hose.
3. Slide the hose onto a 1" C style quick coupler.
4. Position the stainless steel band clamp(s) over the hose on the adapter and tighten the band clamps.
5. Secure the other end of the hoses to the tank fill connection.
6. Connect the quick couplers by opening the latch on the C style coupler (position the metal latch arms out perpendicular to the body of the coupler) then sliding the C coupler onto the F coupler. Pull the metal latch arms back up to the sides of the C coupler.

V4 – Connection To Concentrate Storage

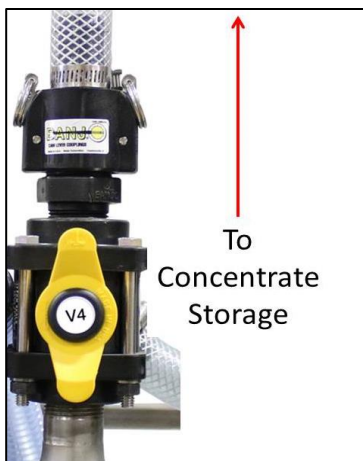

1. Cut 1" ID braided hose to length – from valve V4 to the fill connection for the concentrate tank.
2. Place at least one 1" stainless steel band clamp over one end of the hose.
3. Slide the hose onto a 1" C style quick coupler.
4. Position the stainless steel band clamp(s) over the hose on the adapter and tighten the band clamps.
5. Secure the other end of the hoses to the tank fill connection.
6. Connect the quick couplers by opening the latch on the C style coupler (position the metal latch arms out perpendicular to the body of the coupler) then sliding the C coupler onto the F coupler. Pull the metal latch arms back up to the sides of the C coupler.

OPERATION

When starting the Reverse Osmosis unit there is a sequence in which the pumps will activate. Pressing the START button will first activate the feed pump. In normal operations within 30 seconds the pressure pump will start followed by the recirculation pump.

During any cycle if permeate is not available, use non chlorinated well or spring water.

Startup of System with Little or No Fluid

1. Set the system valves for a rinse cycle (see page 29).
2. Turn off the power to the system at the source.
3. Open the control box by unfastening the latch on the left side then opening the door carefully to the right.
4. Turn off the pressure and recirculation pump breakers:

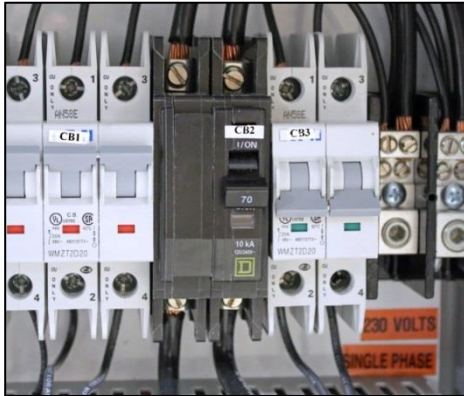

BREAKER ID	CIRCUIT	START POSITION
CB1	Feed Pump	ON
CB2	Pressure Pump	OFF
CB3	Recirculation Pump	OFF

5. Close the control box cover and refasten the latches/buckles.
6. Turn on the power to the system at the source.
7. Ensure your source valves (water or permeate) are open to feed the system.
8. Press the START button to start the feed pump.
9. Run the feed pump until most of the bubbles are gone from the flow meters located on the front of the system. This will take 3 to 4 minutes. Not all the bubbles can be removed.
10. Press the STOP button to stop the feed pump.
11. Turn off the power to the system at the source.
12. Open the control box by unfastening the latches/buckles on the left side then opening the door carefully to the right.
13. Position breakers CB1, CB2 and CB3 to the ON position.
14. Close the control box cover and refasten the latches.
15. Turn on the power to the system at the source.
16. Proceed to the instructions for the Initial System Cleaning.

Initial System Cleaning

To prepare the system after setup;

1. Put approximately 600 US gallons of non-chlorinated well or spring water into a clean permeate storage tank.
2. Set the valves for and run a rinse cycle (see page 29) using a minimum 300 US gallons of water from the permeate tank. While this cycle is running check all fittings, piping, connections and hoses for leaks. Repair as necessary.
3. At the end of the rinse cycle change the position of valve V19 so the liquid flow is directed to the wash tank. When the wash tank is approximately $\frac{2}{3}$ full, return V19 to the drain position.

4. Mix alkaline R/O soap with the liquid in the wash tank until a pH of 11 is reached. Note – this is for FILMTEC E8 membranes. (If other membranes are being used, consult with a Leader Sales person or a local Distributor / Dealer).
5. Set the valves for and run an alkaline wash cycle (see page 32) allowing the system to run until the automatic temperature shutdown at 118°F.
6. Set the valves for and run a rinse cycle (see page 29) using a minimum 300 US gallons of water from the permeate tank.
7. Run the benchmark permeability test (see page 21).

Data Logging

Data on the operation of the system should be recorded and kept. See ATTACHMENT #2 for the data sheet format.

The following data is recorded:

- Date – date the information is collected
- Activity – Concentration cycle (enter a C) or Test (enter a T)
- Sap % - the sugar concentration of the raw sap
- Concentrate % - the sugar concentration of the concentrate from the system – Test results from the concentrate port
- Permeate Flow – gallons per minute of permeate - reading from the top of the stainless steel float in the permeate flow meter
- Concentrate Flow – gallons per minute of concentration from the system – reading from the top of the stainless steel float in the concentrate flow meter
- Temperature – reading from temperature gauge on the control panel of the system (°F)
- Feed Pressure – reading from the pressure gauge on the control panel of the system (psi)
- Membrane Pressure – reading from the pressure gauge on the control panel of the system (psi)
- Water Removal % - percent of water removed from incoming sap – calculated as follows
 - PERMEATE FLOW – Permeate Flow as read from the meter
 - TOTAL FLOW - Add Permeate Flow and Concentrate Flow together
 - Divide PERMEATE FLOW by TOTAL FLOW and multiply the result by 100
 - Record this number as the Water Removal %
- GPH Processed – gallons per hour being processed by the system- calculated as follows
 - TOTAL FLOW – Add Permeate Flow and Concentrate Flow together
 - Multiply Total Flow by 60 and record the resulting number as the GPH Processed

Cycles and Timing

The Springtech EXTREME 1 has 4 defined cycles; Concentrate, Desugar, Rinse and Wash. The following table outlines recommended intervals

CYCLE	INTERVAL
Concentrate	Run 1 to 12 hours dependent on sap quality
Desugar	Run at the end of every Concentrate cycle or at the end of each day
Rinse	Run after the Desugar cycle
Wash	Chemical wash after a rinse. A chemical wash should be run after 12 hours of concentrating or at the end of every day. NOTE: If only a few hundred gallons of sap was run and the machine is to be cleaned, run a hot water wash

The following cycles always need to be run in sequence when used:

- Desugar - Rinse
- Desugar - Rinse – Alkaline Soap Wash – Rinse (also called Alkaline Soap Wash cycle)
- Desugar - Rinse – Alkaline Soap Wash - Rinse - Acid Soak - Rinse – Alkaline Soap Wash – Rinse (also called Chemical Wash cycle)

Permeability Test

The permeability test is used to monitor the performance of the system. It is based on comparing the results of a benchmark test taken when the system is new or at the start of a new season. The permeate flow rate is the basis for the results of the test.

Performing the permeability test for benchmarking:

1. Perform a rinse (see page 29) then fill the wash tank $\frac{2}{3}$ full of permeate by moving valve V19 to the horizontal left position.
2. Set the valves in the wash cycle position (see page 32).
3. Close valve V18.
4. Run the system until the temperature reaches 55°F.
5. Adjust the membrane pressure to 200 psi using valves V1 and V2. Valve V18 may need to be opened slightly.
NOTE: If the starting temperature is higher than 55°F, the same results can be obtained at 70°F and 150psi operating pressure
6. Record the flow rates from the permeate flow meter and from the concentrate meter.
7. Multiply the permeate flow rate by 60 to give a US gallons per hour rate. This number will be the rate (benchmark rate) for comparison to past and future testing. Record this number in the data log with Activity "T".

A permeability test should be performed after each wash cycle. The test is performed as described above for steps 2 through 6. Compare the flow rate obtained in the test with previous benchmark rates. If the flow rate is less than the benchmark rate by 15% or more then further cleaning will be necessary. See the flow chart on page 22.

To calculate the difference to the benchmark do the following calculation:

$$(1 - (\text{Current Measured GPM} / \text{Benchmark GPM})) \times 100$$

Note concerning the chart – if the sap is of good quality (high clarity with no visible suspended material) and the performance of the system cannot be returned to the benchmark level with alkaline soap chemical wash, it will need an acid soak. Acid soak will help remove mineral deposits. If the sap is of poor quality and bacteria is responsible for overall poor performance the alkaline soap wash should remove the problem.

NOTE: This applies to FILMTEC E8 membranes.

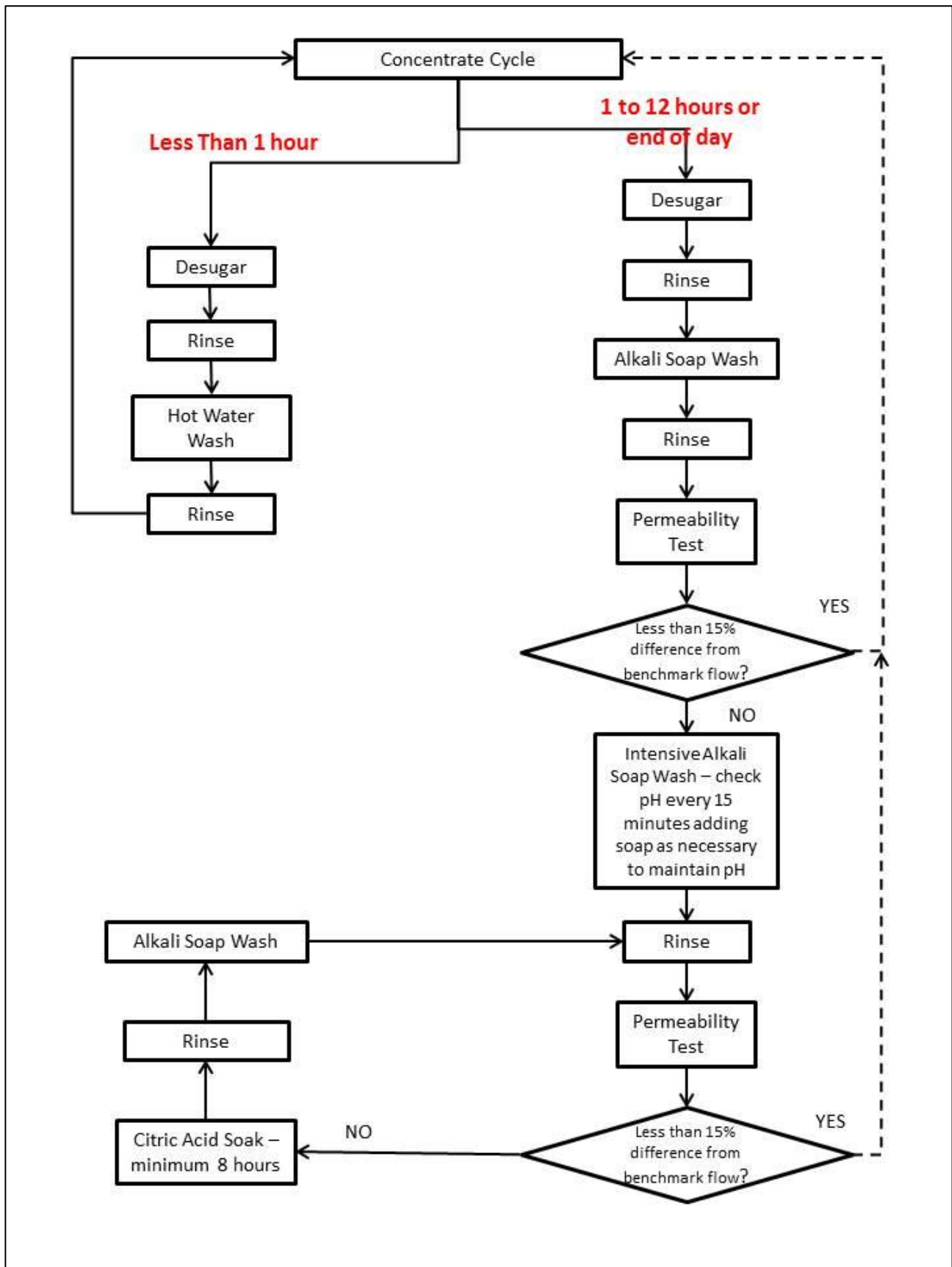

Flow Valve Information

The following is a table illustrating the type of valve being used and where fluid flows when the valves are in certain positions. NOTE: Flow as stated only occurs when all valves are set for the proper cycles.

VALVE	TYPE	SET POSITION	LIQUID FROM - TO	SET POSITION	LIQUID FROM-TO
V3	3 - Way	HANDLE POINTING UP	Membrane to Permeate out	HANDLE POINTING DOWN	Membrane to Valve V19
V4	3 - Way	HANDLE POINTING UP	Membrane to Concentrate out	HANDLE POINTING DOWN	Membrane to Valve V19
V6	3 - Way	HANDLE POINTING TOWARD PUMP	External to Feed Pump	HANDLE POINTING TOWARD WASH TANK PIPE	Wash Tank to Feed Pump
V18	2 - Way	HANDLE POINTING UP	No Flow	HANDLE POINTING HORIZONTAL	Membrane to Valve V19
V19	3 - Way	HANDLE POINTING DOWN	Membrane to Drain	HANDLE POINTING RIGHT	Membrane to Wash Tank
WD	3 - Way	HANDLE POINTING UP	Recirculation to feed pump	HANDLE POINTING HORIZONTAL	Drain Wash Tank

The following is a summary table of the system cycles and the related valve settings for the cycle specified. Detail on the cycle settings is in the sections that follow.

CYCLE	Concentration	Desugar	Rinse	Wash
V1	Open ½ way then adjust	Open ½ way then adjust	Open Fully	Open Fully
V2	Open minimum ½ way then adjust	Open minimum ½ way then adjust	Open Fully	Open Fully
V3	Handle Pointed UP	Handle Pointed UP	Handle Pointed DOWN	Handle Pointed DOWN
V4	Handle Pointed UP	Handle Pointed UP	Handle Pointed DOWN	Handle Pointed DOWN
V6	Handle Pointed TOWARD THE PUMP (Sap)	Handle Pointed TOWARD THE PUMP (Permeate)	Handle Pointed TOWARD THE PUMP (Permeate)	Handle Pointed WASH TANK PIPE
V18	Handle Pointed UP (closed)	Handle Pointed UP (closed)	Handle Pointed HORIZONTAL (open)	Handle Pointed UP (closed)
V19	Handle Pointed RIGHT	Handle Pointed RIGHT	Handle Pointed DOWN	Handle Pointed RIGHT
WD	Handle Pointed UP	Handle Pointed UP	Handle Pointed UP	Handle Pointed UP / HORIZONTAL
Drains	Closed	Closed	Closed	Closed

NOTE: During the Rinse cycle, if the machine shuts down due to low pressure and the feed line has been bled or during the Wash cycle if the machine shuts down due to low pressure, check the prefilters. If the prefilters are dirty, replace and retry the rinse/wash cycle. If the prefilters appear clean or are new and the problem continues, partially close valve V18 until an operating pressure of 50 – 80 psi is reached and run the remainder of the cycle.

Adjusting V1 and V2 for Operations

The maximum pressure is 550 psi with a recommended level of 200 - 350 psi.

V2 is adjusted for concentration output by flow or % sugar.

There are two methods of determining how to set the V1 and V2 valves.

- Concentrate Preferred – Turn V1 to a minimum pressure and turn V2 until the desired concentration is obtained. Adjust V1 until the pressure desired is reached. Readjust V2 until the concentration desired is reached.
- Volume Preferred – Turn V2 to a minimum and Turn V1 until the desired flow is reached. Adjust V2 until the concentration desired is reached. Readjust V1 until the desired flow is reached.

Sample Port Use

When using the concentrate sample port, run approximately 1 test cup of concentrate through in order to purge the lines. Pour that cup back into the raw sap tank. Draw a second cup and sample.

The permeate sampling port should be purged as done with the concentrate sample port. The permeate through this ports should be sampled once per day.

Concentrate Cycle

In this cycle the system inputs sap or pre-concentrated sap and cycles it through the membranes resulting in a concentrated liquid (concentrate) and the water being removed (permeate).

There are two output options within the Concentrate Cycle. The first is to direct the concentrate to the concentrate tank. The second is to direct the concentrate to the sap tank – this is called the Sap Concentration Loop. Valves are required between valve V4 and the concentrate tank allowing the option for concentrate to be directed to the sap tank (valves sold separately).

Standard Concentrate Output

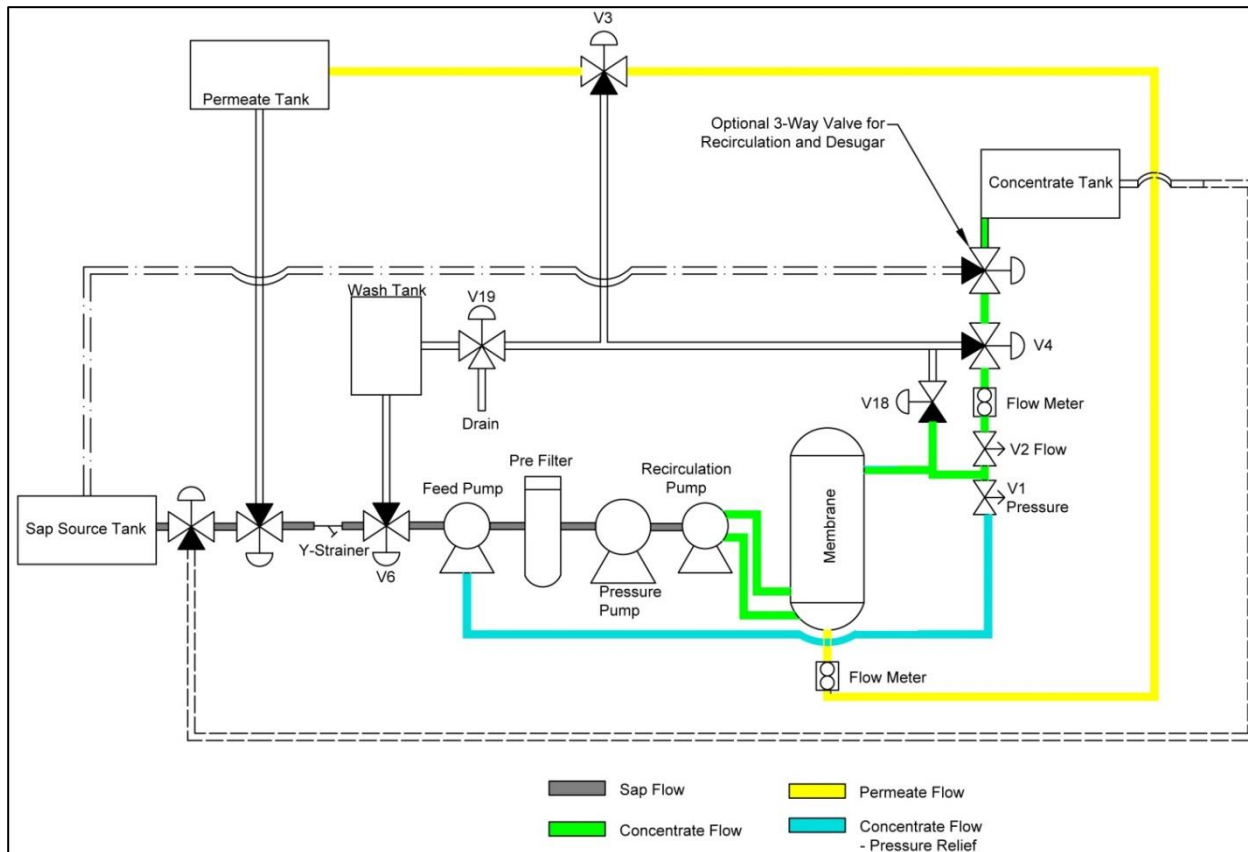

Sap Concentration Loop

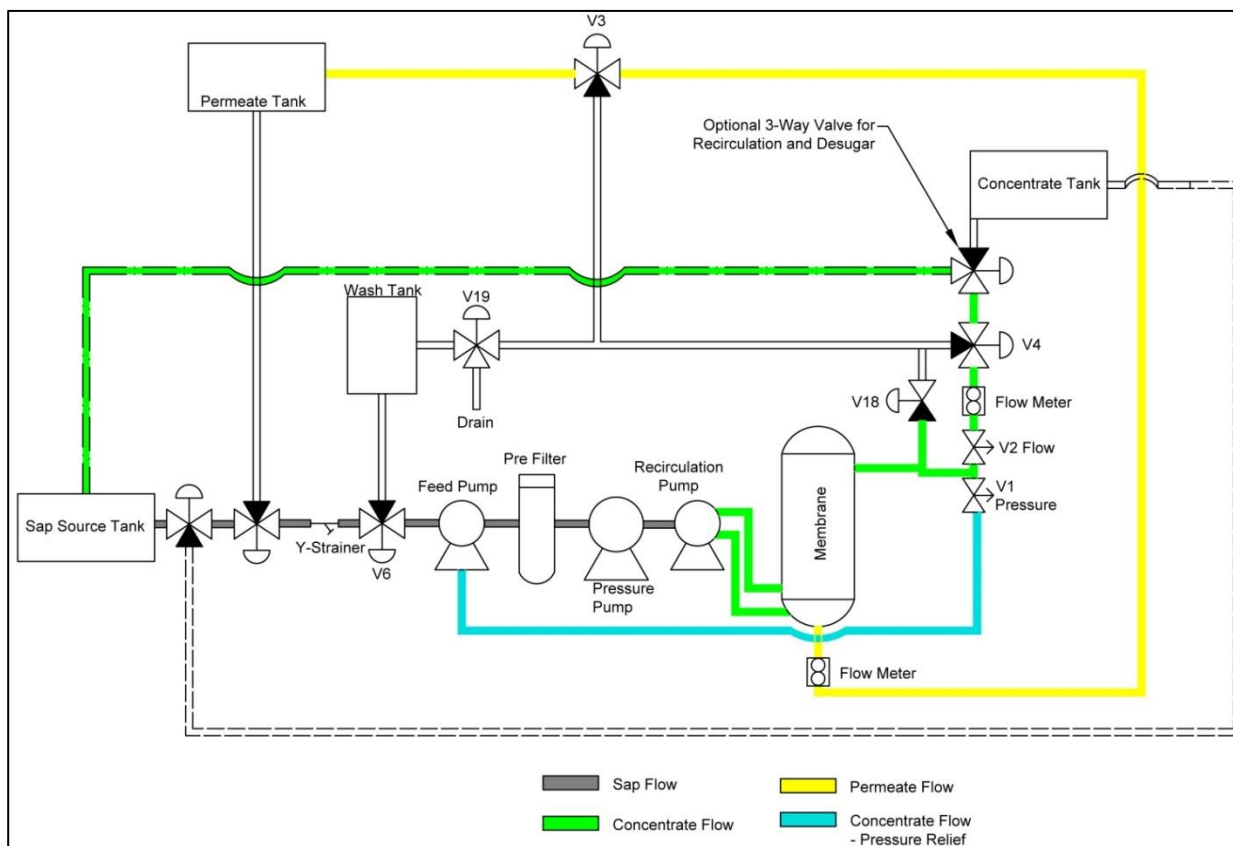

Concentrate Cycle Valve Settings – also available on the Quick Start Guide

1. Position the valves as follows:



V1 – Open ½ way to start then adjust to the desired maximum pressure (Do NOT Exceed 550 psi)

V2 – Open a minimum of ½ way to start then adjust to the desired concentration level or flow.

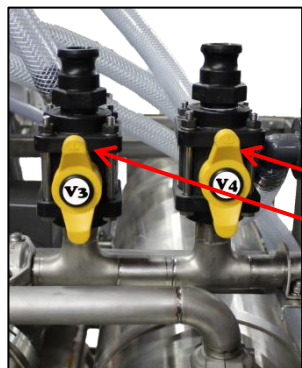

V3 – The flow indicator should be UP

V4 – The flow indicator should be UP



V6 – The handle should be toward the pump housing. Input from the liquid source selector should be from the raw sap (or previously concentrated sap).



V18 – Valve handle is vertical up. Valve is closed.

V19 – With V3 and V4 in the concentrate setting V19 should have no flow. Direct V19 to the wash tank as a precaution.

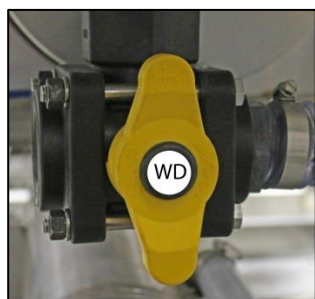

WD – The flow indicator should be up.

2. Press the START button on the control panel. Within 30 seconds all pumps should start.
3. If the system does not continue to run due to a LOW PRESSURE ALARM;
 - a. Light is SOLID - Repeat Step 2 up to 2 additional times. The STOP ALARM RESET button will need to be pressed after each time.
 - b. Light is BLINKING – Press the STOP button to reset the alarm. Check the prefilters, changing as necessary. Repeat Step 2.

4. If the system does not start on the third try, bleed the system. To bleed the system, open the valve on the top of the strainer (installed before valve V6) until all the air is released from the system. Close the bleed valve.
5. When the machine has started, adjust V1 and V2 to produce the desired conditions.

Desugar Cycle

In this cycle the permeate is run in a concentrate cycle to flush accumulated sugar from the membrane. Dependent on the operation, the Desugar process may be done in one of the following ways:

- Flushing liquid for the full cycle is run to the concentrate tank
- Flushing liquid for the full cycle is run to the sap tank
- Flushing liquid for the part of the cycle with the highest concentration of sugar is run to the concentrate tank then the remainder is run to the sap tank

Flush Liquid Running To Concentrate Tank (first part of Desugar with higher sugar % being rinsed out)

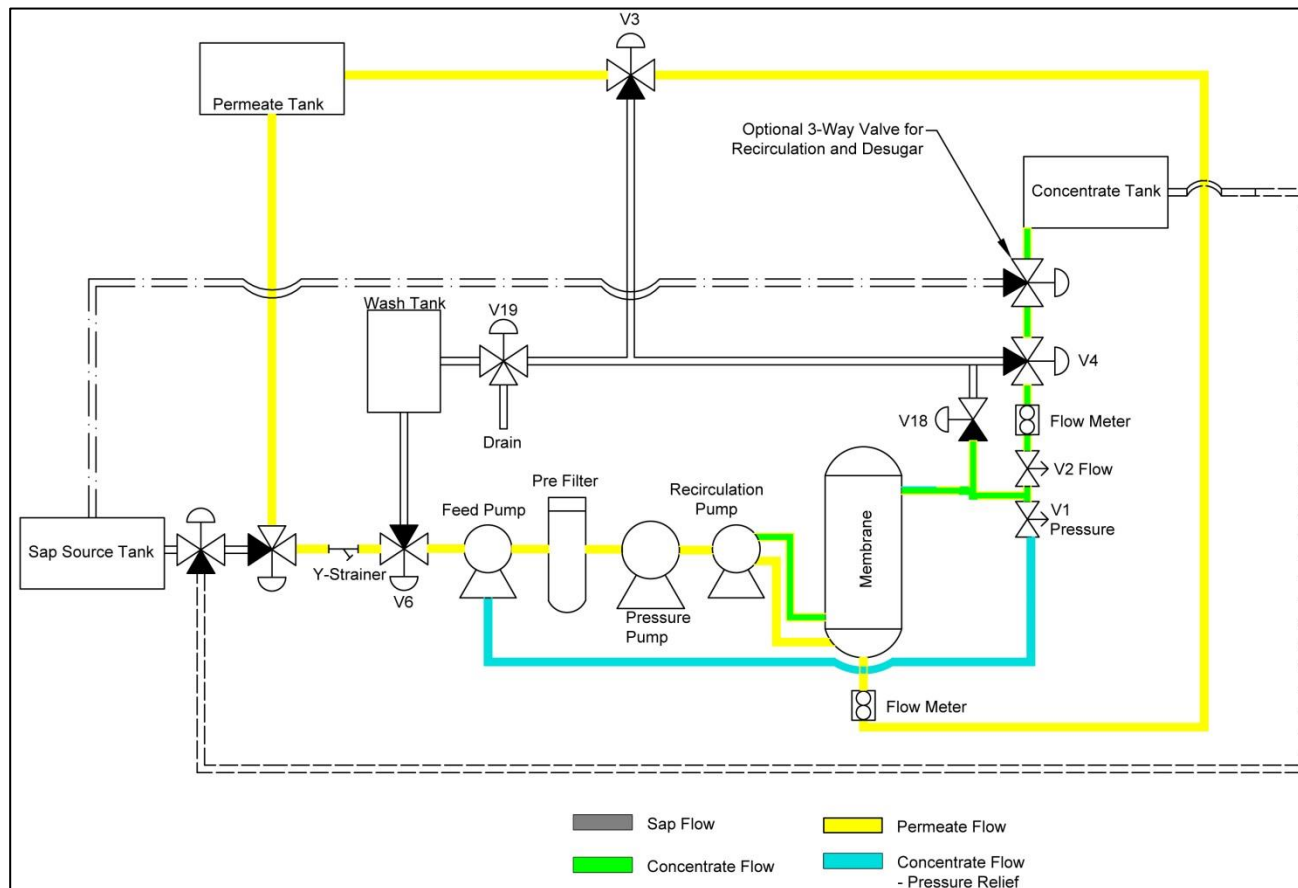

Flush Liquid Running To Sap Tank (later part of Desugar with lower sugar % being rinsed out)

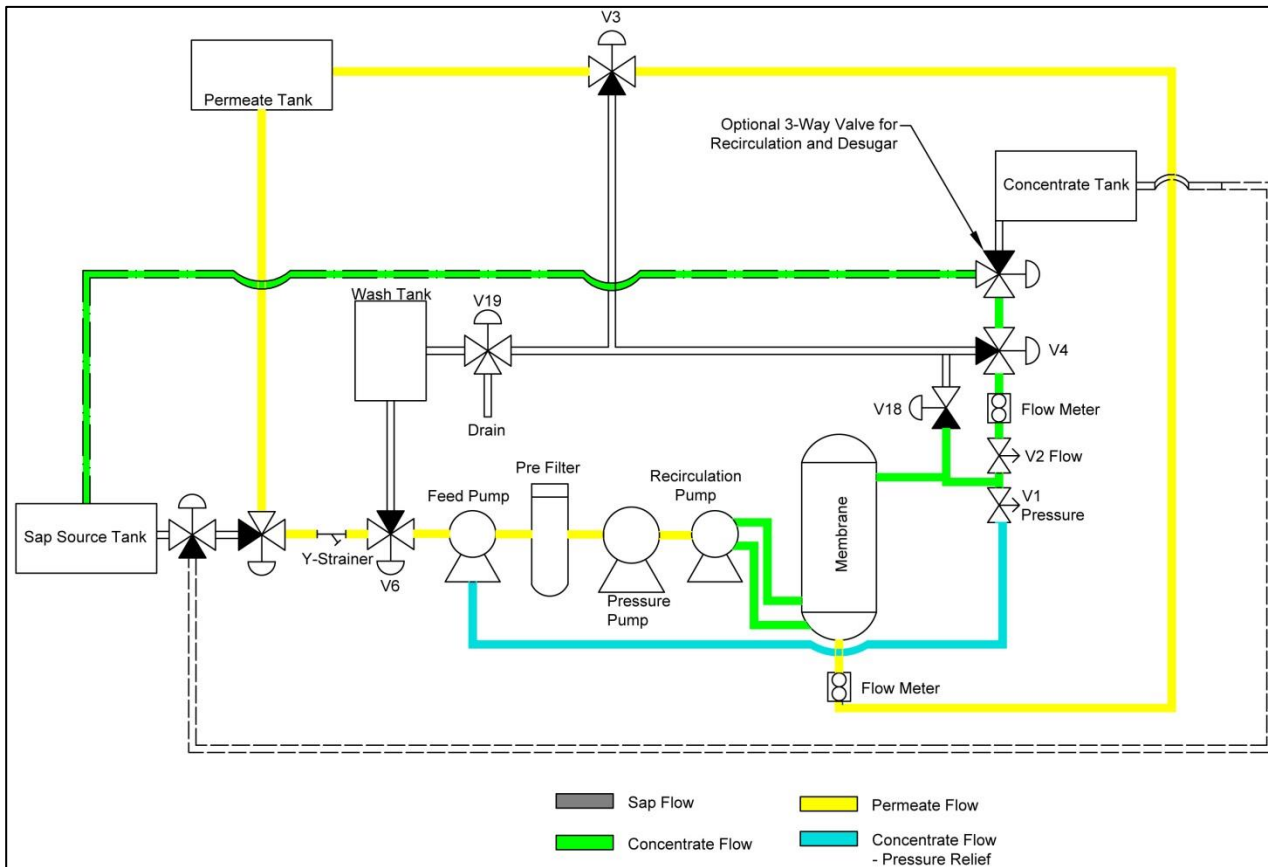

Desugar Cycle Valve Settings – also available on the Quick Start Guide

1. Position the valves as follows:



V1 – Leave valve where it was set during the concentration cycle

V2 – Leave the valve where it was set during the concentration cycle.



V3 – The flow indicator should be UP. Valve is open to the Permeate tank.

V4 – The flow indicator should be UP. Valve is open to the Concentrate tank.



V6 – The handle should be toward the pump housing. Input from the liquid source selector should be from the permeate tank.



V18 – Valve handle is vertical up. Valve is closed.

V19 – With V3 and V4 in the concentrate setting V19 should have no flow. Direct V19 to the wash tank as a precaution.

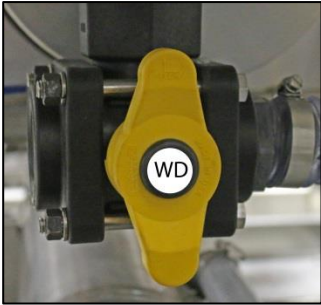

WD – The flow indicator should be up.

2. Press the START button on the control panel. Within 30 seconds all pumps should start.
3. If the system does not continue to run when you release the START button, due to a low Pressure Alarm, repeat Step 2 up to 2 additional times. The STOP ALARM RESET button will need to be pressed after each time.
4. If the system does not start on the third try, bleed the system. To bleed the system, open the valve on the top of the strainer (installed before valve V6) until all the air is released from the system. Close the bleed valve.
5. Check the concentrate sugar % level approximately every 5 minutes. The Desugar cycle should be run until the concentrate sugar is down to at least 1% to 2%.

Rinse Cycle

In this cycle permeate is run through the system at high volume and low pressure to rinse sugar, minerals and bacteria from the R/O. A rinse cycle is required before and after every wash cycle. At least 300 US gallons of permeate is required in a rinse following a chemical wash. Desugar and rinsing the system every 4 to 6 hours can help to maintain higher performance rates.

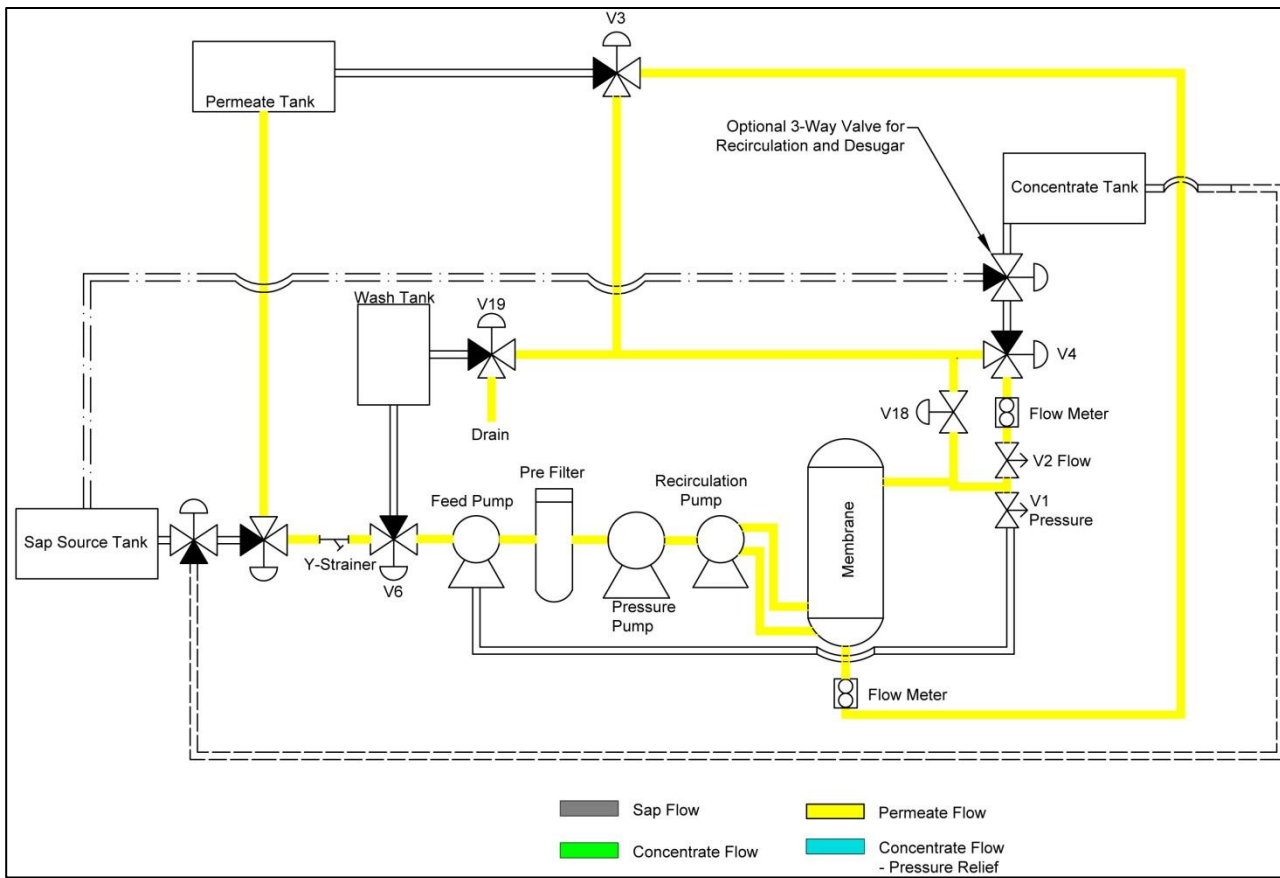

Rinse Cycle Valve Settings – also available on the Quick Start Guide

1. Position the valves as follows:



V1 – Open the valve completely

V2 – Open the valve completely



V3 – The flow indicator should be DOWN. Valve is open for recirculation within the system.

V4 – The flow indicator should be DOWN. Valve is open for recirculation within the system.



V6 – The handle should be toward the pump housing. Input from the liquid source selector should be from the permeate tank.



V18 – Handle should be parallel to the pipe.
Valve is open.



V19 – Handle should be vertical down.
Valve is open to drain.

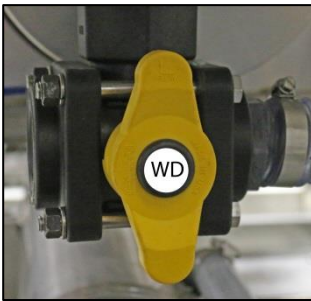

WD – The flow indicator should be up.

2. Press the START button on the control panel. Within 30 seconds all pumps should start – some air purge may be required.
3. If the system does not continue to run due to a LOW PRESSURE ALARM;
 - a. Light is SOLID - Repeat Step 2 up to 2 additional times. The STOP ALARM RESET button will need to be pressed after each time.
 - b. Light is BLINKING – Press the STOP button to reset the alarm. Check the prefilters, changing as necessary. Repeat Step 2.
4. If the system does not start on the third try, bleed the system. To bleed the system, open the valve on the top of the strainer (installed before valve V6) until all the air is released from the system. Close the bleed valve.
5. If the system does not start due to a LOW PRESSURE ALARM partially close valve V18 until an operating pressure of 50 – 80psi is reached and run the remainder of the cycle.
6. Run the Rinse cycle until a minimum of 300 US gallons of stored permeate has been used. If the Rinse is to be followed by a Wash cycle, at the end of the rinse, fill the wash tank approximate $\frac{2}{3}$ full by turning the V19 valve horizontally right.

NOTE: If the machine shuts down due to low pressure and the feed line has been bled, check the prefilters. If the prefilters are dirty, replace and retry the rinse cycle. If the prefilters appear clean or are new and the problem continues, partially close valve V18 until an operating pressure of 50 – 80 psi is reached and run the remainder of the cycle.

Wash Cycle

There are three different wash cycles. A hot water wash which can be run when good clear sap was processed and the flows are still good. An alkaline soap wash is done to remove bacteria from the system. Generally alkali washes alone are used where the sap quality is poor and flow rates recover to normal after the wash. An acid soak and wash is done to remove mineral deposits from the system. Generally the acid soak is used where sap quality is good and the system does not recover flow rates after the alkaline soap wash.

Hot Water Wash

1. Perform a rinse cycle (see page 29) using a minimum of 300 US gallons of permeate stored for system rinsing.
2. Toward the end of the rinse cycle, turn valve V19 toward the wash tank feed position. This will direct the flow of permeate to the wash tank. When the wash tank is $\frac{3}{4}$ full, return V19 to the drain position.
3. Set the valves as listed below.
4. Start and run the system until it shuts down automatically. The system will shut down when the temperature reaches 118°F.
5. Perform a Rinse cycle (see page 29) using a minimum of 300 US gallons of stored permeate water.
NOTE: If the machine shuts down due to low pressure, check the prefilters. If the prefilters are dirty, replace and retry the wash cycle. If the prefilters appear clean or are new and the problem continues, partially close valve V18 until an operating pressure of 50 – 80 psi is reached and run the remainder of the cycle.

Alkaline Soap Wash

1. Perform a rinse cycle (see page 29) using a minimum of 300 US gallons of permeate stored for system rinsing.
2. Toward the end of the rinse cycle, turn valve V19 toward the wash tank feed position. This will direct the flow of permeate to the wash tank. When the wash tank is $\frac{3}{4}$ full, return V19 to the drain position.
3. At the completion of the rinse cycle, add R/O soap (LEADER Order # 69992) to the wash tank and mix. Add R/O soap until a pH of 11 is reached. NOTE: This applies to FILMTEC E8 membranes. For other membranes consult with a LEADER sales person or a local distributor / dealer.
4. Set the valves as listed below.
5. Start and run the system until it shuts down automatically. The system will shut down when the temperature reaches 118°F.
NOTE: If the machine shuts down due to low pressure, check the prefilters. If the prefilters are dirty, replace and retry the wash cycle. If the prefilters appear clean or are new and the problem continues, partially close valve V18 until an operating pressure of 50 – 80 psi is reached and run the remainder of the cycle.
6. Perform a Rinse cycle (see page 29) using a minimum of 300 US gallons of stored permeate water.
7. Drain the wash tank. The drain valve is located under the wash tank. Turn the flow indicator to the left.

Intensive Alkaline Soap Wash

1. Follow the directions for the Alkaline Soap Wash.
2. Check the pH of the wash solution every 15 minutes. Maintain the pH by adding soap.

Acid Soak

1. Perform an alkaline Soap wash as listed above.
2. At the end of the rinse cycle (following the wash) turn valve V19 toward the wash tank feed position. Run until the wash tank is approximately $\frac{3}{4}$ full, return V19 to the drain position.
3. Add $\frac{1}{2}$ cup of citric acid to the wash tank and mix.
4. Run a wash cycle. The system will shut down when the temperature reaches 118°F.
5. Shut off the system and allow the acid solution to soak for 8 to 24 hours.
6. Drain the wash tank.
7. Perform a rinse cycle (see page 29) using a minimum of 300 US gallons of stored permeate water.

8. Perform an alkaline soap wash as detailed above.
9. Drain the wash tank.
10. Perform a rinse cycle (see page 29) using a minimum of 300 US gallons of stored permeate water.

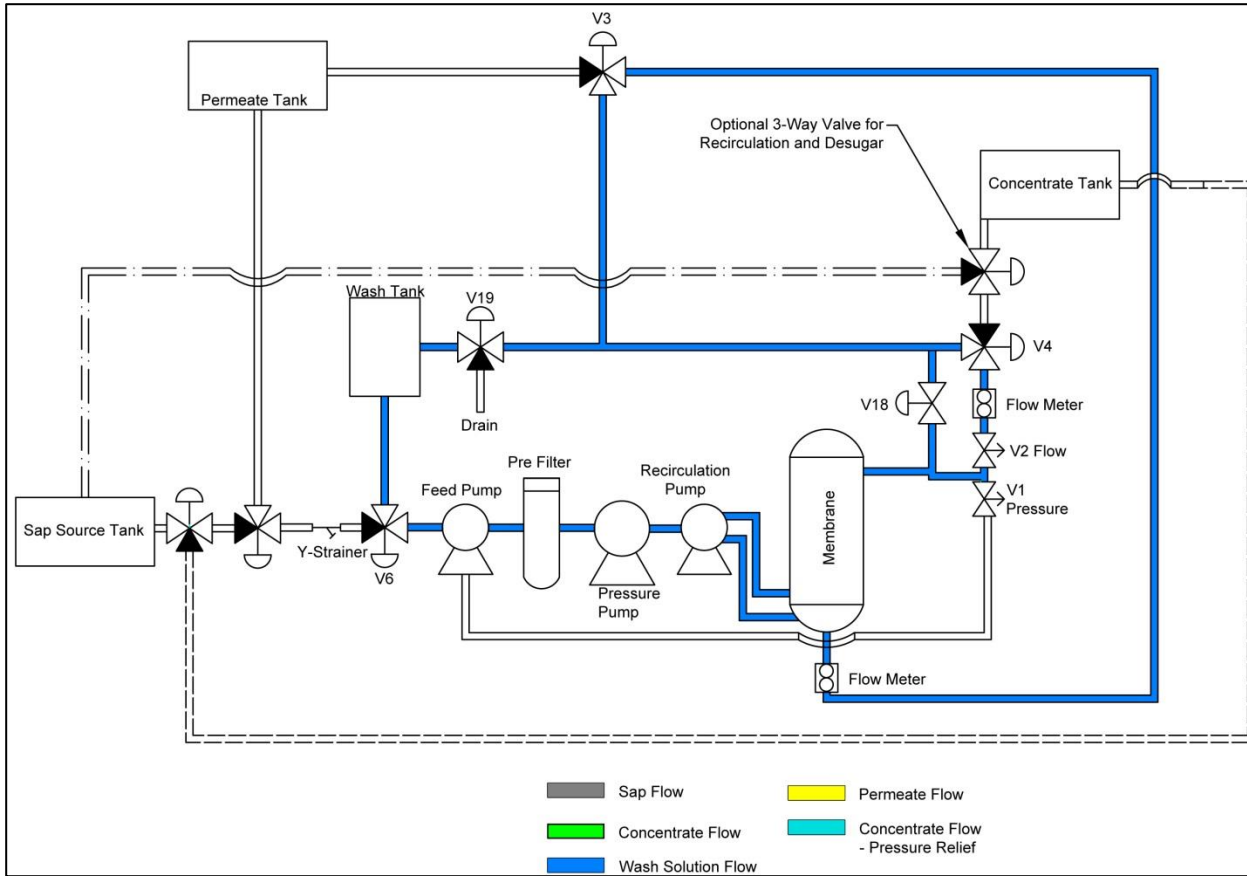

Wash Cycle Valve Settings – also available on the Quick Start Guide

1. Position the valves as follows:



V1 – Open the valve completely

V2 – Open the valve completely

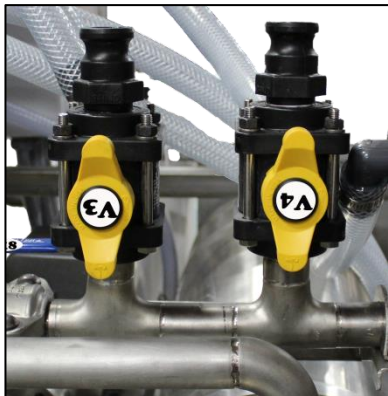

V3 – The flow indicator should be DOWN. Valve is open for recirculation

V4 – The flow indicator should be DOWN. Valve is open for recirculation.



V6 – The handle should be toward the wash tank line. Valve is open to the wash tank.



V18 – Handle should be parallel to the pipe. Valve is open.



V19 – Handle should be horizontal right. Valve is open to the wash tank.

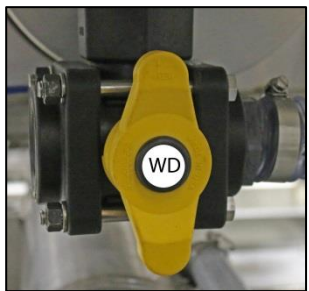

WD – The flow indicator should be up.

2. Add the soap required for the type of wash to be performed. NOTE: Ensure the wash tank is filled first.
3. Press the START button on the control panel. Within 30 seconds all pumps should start.
4. For an alkaline soap wash - run the Wash cycle until the system shuts down automatically. The system shutdown is based on the temperature of the liquid. When the liquid reaches 118°F the system will shut down.
5. If the system does not continue to run due to a LOW PRESSURE ALARM;
 - c. Light is SOLID - Repeat Step 2 up to 2 additional times. The STOP ALARM RESET button will need to be pressed after each time.
 - d. Light is BLINKING – Press the STOP button to reset the alarm. Check the prefilters, changing as necessary. Repeat Step 2.
6. If the system does not start on the third try, bleed the system. To bleed the system, open the valve on the top of the strainer (installed before valve V6) until all the air is released from the system. Close the bleed valve.
7. If the system does not start due to a LOW PRESSURE ALARM partially close valve V18 until an operating pressure of 50 – 80psi is reached and run the remainder of the cycle.
8. Press the STOP ALARM RESET button to reset the alarm.

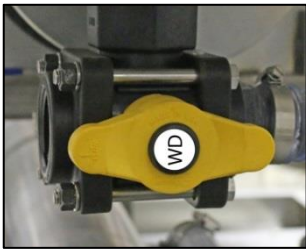

9. Open the wash tank drain valve to drain the wash tank. When the wash tank is empty, return the drain valve to the recirculation position.

10. Run a rinse cycle (see page 29) using a minimum of 300 US gallons of permeate from the permeate storage tank.
11. Do a permeability test (see page 21). If the test is good, continue the rinse cycle with any additional permeate.

MAINTENANCE

Pre Filters

When the feed pump pressure drops below 20 psi, the prefilters may need to be changed. The procedure to change the prefilters is as follows: NOTE – there are two filter housings mounted side by side. Change each one separately.



1. Loosen and remove the lower portion of the filter housing.
2. Empty the liquid from the housing.



3. Remove the filter from the housing.



4. Wipe the O-rings of the top of the assembly then apply a light coating of food grade grease such as LEADER order #64436.

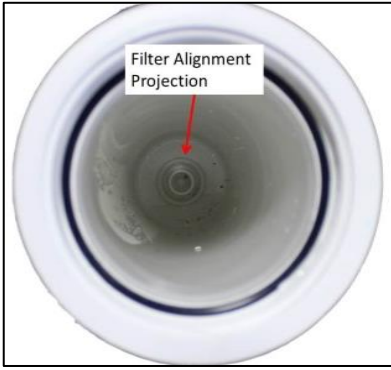

5. Rinse out the housing. Insert a new filter into the housing aligning one of the open ends over the alignment projection.



6. Bring the lower filter housing, with the filter installed, up to the underside of the top of the filter housing on the system. Carefully align the open top of the filter with the alignment projection in the top of the filter housing. Thread the bottom of the housing onto the top of the housing and securely hand tighten.

Membrane Removal and Installation

Removal

1. Stop the system by pressing the STOP button.
2. Position valve V6 to the wash position.
3. Set valves V3 and V4 in a rinse cycle position.

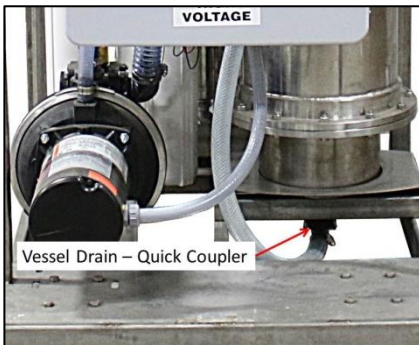

4. Disconnect the permeate line quick coupler from under the membrane housing. Allow the vessel to drain until empty.



5. Remove the outer sections of the recirculation pump clamps by loosening and removing the nuts and bolts.



6. Under the outer clamp parts are rubber seals. Slide the seals toward the recirculation pump so they are not over the membrane housing connection.

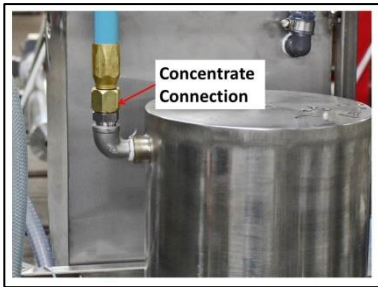

7. Loosen and remove the concentrate hose from the concentrate connection on the housing.



8. Remove the nuts and bolts securing the strap around the vessel. **CAUTION:** The housing is heavy and will now be loose.



9. Remove the housing from the system and place it upside down on a solid surface ex. floor. **CAUTION: Housing is heavy.**



10. Remove the nuts and bolts securing the cap to the housing then remove the

cap from the membrane.

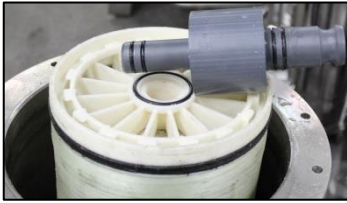

11. Remove the alignment coupling from the end of the membrane.



12. Remove the membrane from the housing and then remove the membrane plug from the end of the membrane. Note – the membrane will contain liquid.

Installation

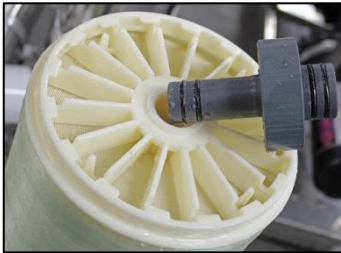

1. Inspect and replace if necessary the four (4) O-rings of the membrane plug. Lightly lubricate the O-rings with food grade grease then slide the plug into the membrane.



2. Insert the membrane into the housing with the plug end down. Ensure the membrane goes all the way into the vessel with the membrane plug seated in the housing.



3. Check the O-rings on the alignment coupler, replace if damaged. Lightly lubricate the O-rings, if necessary, with food grade grease then insert the coupling into the end of the membrane. Lubricate the membrane O-ring (brine seal) with food grade grease.



4. Inspect the O-rings of the cap and replace if damaged. Lubricate the O-rings with food grade grease, if necessary.



5. Place the cap on the housing aligning the two connections and the holes in the cap and the housing.



6. Secure the cap to the housing with the nuts and bolts removed earlier.



7. Invert the housing and place it into the hole in the system frame while aligning the connections on the housing with those of the recirculation pump.



8. Place the securing strap around the housing and loosely tighten the nuts and bolts to hold it in place.





9. Finish aligning the recirculation pump connections then slide the rubber coupler over the membrane housing pipe so that it rests between the grooves.
10. Place the two clamp halves over the rubber seal and aligning the pieces with the grooves in the connector pipes. Place the bolts in the clamp and tighten. Check to ensure the clamp is properly seated and tightened by ensuring the two halves fit tightly together.



11. Thread in and tighten the concentrate line to the connection at the top end of the housing.
12. Ensure all fittings are aligned and tight then tighten the nuts and bolts on the securing strap.



13. Reconnect the permeate line to the end of the membrane housing using the quick coupler.

14. Follow the instructions for the Beginning of Season Startup (see page 42).

Daily

Each day, it is recommended the following be done:

1. Remove, clean and reinstall the strainer in the Y-strainer.
2. Sample the permeate liquid from the sampling port;
 - a. Purge the permeate sample line by running the system and drawing a volume of permeate from the port approximately equal to a test cup.
 - b. Draw a sample for testing. Test the permeate sugar level using either a refractometer or a hydrometer.
 - c. If the results indicate there is any sugar present there is a possible problem with the membrane O-rings, connector or alignment coupling. Check the troubleshooting chart.
3. Check all hoses, piping, fittings and connections for leaks. Repair as necessary.
4. Run a cycle of Desugar (see page 27) – Rinse (see page 29) – Alkaline Soap Wash (see page 32) – Rinse (see page 29)

5. Do a Permeability test (see page 21)
6. Inspect and clean storage tanks
 - a. Permeate
 - b. Concentrate
 - c. Sap

Periodic

1. When the feed pump pressure drops below 20 psi, the prefilters need to be changed (see page 35).
2. If a permeability test (see page 21) indicates the system performance is less than 85% of the benchmarked performance;
 - a. Run a cycle of Rinse (see page 29) – Intensive Alkaline Soap Wash (see page 32) (checking pH 2 to 3 times and adding additional soap as necessary)– Rinse (see page 29) and repeat the permeability test (see page 21).
 - b. If necessary or at the end of the season, run a cycle of Rinse (see page 29) – Acid Wash (see page 32) – Rinse (see page 29) – Alkaline Soap Wash (see page 32) – Rinse (see page 29) and repeat the permeability test (see page 21).
3. Pump motors will need to be lubricated. The following table describes the lubrication requirements. NOTE: The output of the grease gun will need to be measured prior to lubricating the bearings in order to ensure the proper amount of lubrication is used.
 - a. All bearings require EXXON POLYREX EM lubricant.

MOTOR ID	MOTOR FUNCTION	HP	Bearing Location	Lubrication Interval (hrs)	Lubrication Amount (ounces)	Bearing Location	Lubrication Interval (hrs)	Lubrication Amount (ounces)
M2	Pressure Pump	5	Pump end	5500	5	Non Pump End	5500	3.9

End Of Season Shutdown and Storage

If permeate is not available to perform the rinse and wash cycles stated in the following procedure, obtain the necessary volume of water using non chlorinated well or spring water.

1. Do a rinse cycle (see page 29) – alkaline soap wash (see page 32) – rinse cycle (see page 29).
2. Do an acid soak cycle (see page 32) allowing the system to soak for 1 to 7 days, starting the system once per day and allowing it to run to the auto stop temperature at 118°F.
3. Do a rinse cycle (see page 29) – intensive alkaline soap wash (see page 32) – rinse cycle (see page 29)
4. Perform a permeability test (see page 21). If the test result shows a difference of greater than 15% to the benchmark, repeat the process starting with Step 2.
5. Drain the wash tank (valve WD) then close the drain.
6. In the wash tank mix:
 - a. 13 US gallons of permeate
 - b. 2 US gallons of glycol
 - c. 1 Tablespoons of membrane preservative
7. Set the system valves for a wash cycle (see page 32) and run the system for 15 minutes. Drain the wash tank.
8. Empty then reinstall the prefilter housings.
9. Drain the pumps then close all drains.
10. Maintain a temperature minimum of 40°F to 50°F in the area where the system is stored. Do not allow the system to freeze.
11. Drain and clean all storage tanks. Cover them in order to keep dirt and pests out. NOTE: If permeate is not available for cleaning, use non-chlorinated well or spring water.

Beginning of Season Startup

As permeate will not be available to perform the rinse and wash cycles stated in the following procedure, obtain the necessary volume of water using non chlorinated well or spring water.

1. Connect the reverse osmosis system to the concentrate, permeate and feed lines.
2. Replace prefilters.
3. Open the control box by unfastening the latches/buckles of the left side then opening the door carefully to the right.
4. Turn off the pressure and recirculation pump breakers:



BREAKER ID	CIRCUIT	START POSITION
CB1	Feed Pump	ON
CB2	Pressure Pump	OFF
CB3	1.5 HP Recirculation Pump	OFF

5. Close the control box cover and refasten the latches/buckles.
6. Ensure your source valves (water or permeate) are open to feed the system.
7. Position the valves for the rinse cycle (see page 29).
8. Press the START button to start the feed pump.
9. Run the feed pump until most of the bubbles are gone from the flow meters located on the front of the system. This will take 3 to 4 minutes. Not all the bubbles can be removed.
10. Press the STOP button to stop the feed pump.
11. Check all fittings, hoses, connections and parts of the system for leaks. Repair as necessary.
12. Open the control box by unfastening the latches/buckles of the left side then opening the door carefully to the right.
13. Position breakers CB1, CB2 and CB3 to the ON position.
14. Close the control box cover and refasten the latches.
15. Run a rinse cycle (see page 29) until a minimum of 300 US gallons of water have been processed. Near the end of the rinse cycle turn valve V19 down and fill the wash tank 2/3 full. Return valve V19 to its original position.
16. Run a hot water wash (see page 32).
17. Repeat the rinse cycle (see page 29) again filling the wash tank as specified then add R/O soap (LEADER Order # 69992) to the wash tank and mix. Add R/O soap until a pH of 11 is reached.
18. Run an alkaline wash cycle (see page 32).
19. Perform a rinse cycle (see page 29) using a minimum of 300 US gallons of water.
20. Drain the wash tank using valve WD (horizontal left) then reposition the valve for recirculation (vertical up).
21. Perform a permeability test (see page 21).
 - a. Compare the results to the results of the test when the system was new. If the results are not acceptable contact LEADER EVAPORATOR or your local Distributor / Dealer for assistance.
 - b. Record the results, if acceptable, and use these results as the reference for test for the season.

TROUBLESHOOTING CHART

The following conditions may occur during operations.

CONDITION	CAUSE	ACTION
Feed pump does not start when START button is pressed	No power	Verify power is "ON" at the source.
Feed pump starts but system does not continue running	Low Pressure	Inspect incoming plumbing for leaks
		Check and clean Y-strainer
		Pre Filters need changing (alarm light blinking)
	No liquid coming from storage	System needs to be bled
Low rate found during permeability test	Suspected bacteria buildup	Check the positions of all valves
	Suspected Mineral Buildup	Rewash system with R/O alkali soap
Sugar in the permeate	Leak at alignment coupling or membrane plug	Acid wash system
	Membrane deterioration	Replace O-ring or alignment coupling or the membrane connector
Temperature Alarm Indicator	Normal operations for wash cycle	Replace membrane
Motor Failure Alarm Indicator	Motor contactor has tripped	Reset alarm by pressing the STOP button
		Contact LEADER Technical Service

ATTACHMENT #1A – ELECTRICAL SCHEMATIC – No Pressure Differential Switch

Service 230 Vac, 1 Phase, 75(85 opt.) Amps, 2 Wire & Ground

Danger
High Voltage

Note:
- All control wire is 16 AWG Red unless otherwise noted.
- All terminal blocks are labeled to their corresponding wire numbers.

TORQUE TERMINALS TO 15lb-in.

USE 75°C COPPER CONDUCTORS ONLY

CONDUIT/FITTINGS TO MEET ENCLOSURE RATING

BONDING OF CONDUCTORS TO BE TIED WITH MAIN GROUND

MAIN DISCONNECT MUST BE ADDED AT INSTALLATION

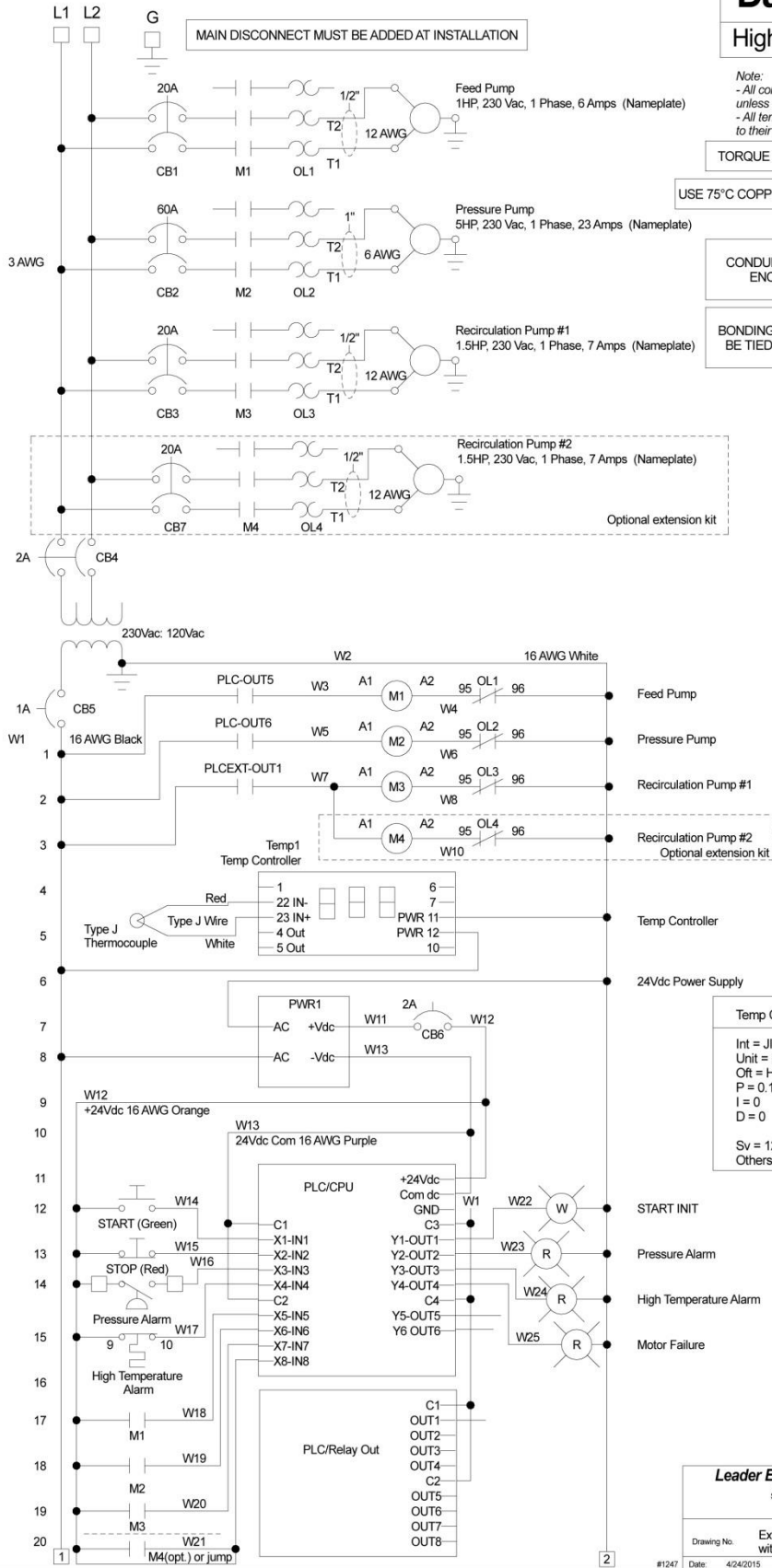

Temp Controller Programming

Int = JIC
Unit = F
OfT = HEAT
P = 0.1
I = 0
D = 0

Sv = 120
Others = Default

Leader Evaporator Co., Inc
49 Sherman Drive
Swanton, VT 05498
(802) 858-5444

Drawing No: Extreme 1 sch with optional expansion pump
#1247 Date: 4/24/2015 Rev: 3 By: SM Size: A

ATTACHMENT #1B - ELECTRICAL SCHEMATIC

Service 230 Vac, 1 Phase, 75(85 opt.) Amps, 2 Wire & Ground

Danger
High Voltage

Note:
- All control wire is 16 AWG Red unless otherwise noted.
- All terminal blocks are labeled to their corresponding wire numbers.

TORQUE TERMINALS TO 15lb-in.

USE 75°C COPPER CONDUCTORS ONLY

CONDUIT/FITTINGS TO MEET ENCLOSURE RATING

BONDING OF CONDUCTORS TO BE TIED WITH MAIN GROUND

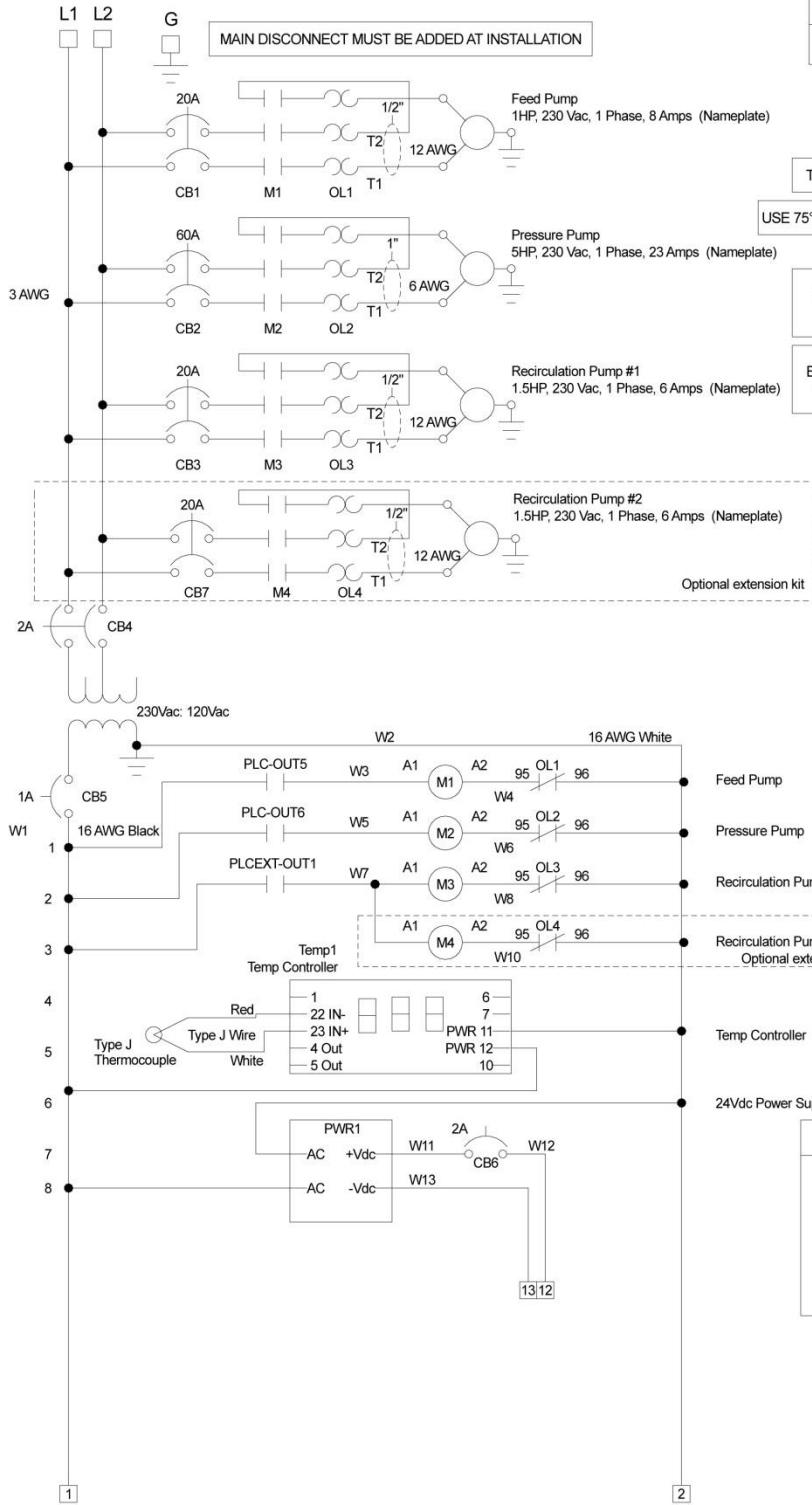

Temp Controller Programming

Int = JIC
Unit = F
Of = HEAT
P = 0.1
I = 0
D = 0

Sv = 120
Others = Default

1/2

Leader Evaporator Co., Inc
48 Jomergel Drive
Swanton, VT 05488
(802) 868-5444

Drawing No. **Extreme 1 sch with optional expansion pump**

#1247 Date: 11/17/2015 Rev: 4 By: SM Size: A

Note:
 - All control wire is 16 AWG Red unless otherwise noted.
 - All terminal blocks are labeled to their corresponding wire numbers.

TORQUE TERMINALS TO 15lb-in.

USE 75°C COPPER CONDUCTORS ONLY

CONDUIT/FITTINGS TO MEET ENCLOSURE RATING

BONDING OF CONDUCTORS TO BE TIED WITH MAIN GROUND

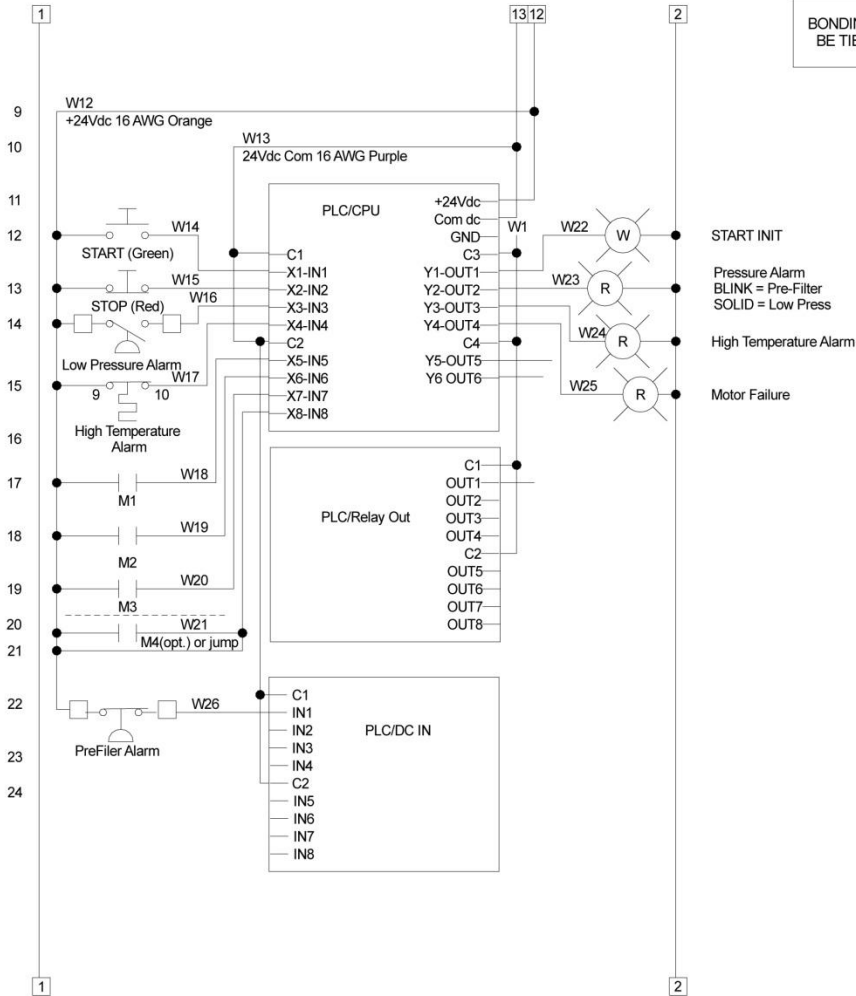

2/2

Leader Evaporator Co., Inc			
<small>49 Jönörgerin Drive Swanton, VT 05488 (802) 858-5444</small>			
Drawing No. Extreme 1 sch with optional expansion pump			
<small>#1247</small>	<small>Date: 11/17/2015</small>	<small>Rev: 4</small>	<small>By: SM Size: A</small>

ATTACHMENT #1C – ELECTRICAL SCHEMATIC

Service 230 Vac, 1 Phase, 75(85 opt.) Amps, 2 Wire & Ground

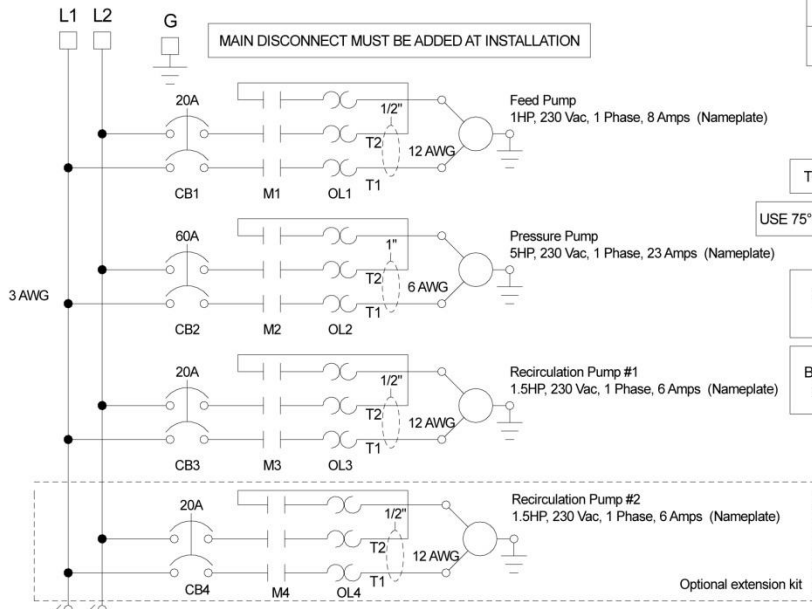

Danger

High Voltage

Note:
- All control wire is 16 AWG Red unless otherwise noted.
- All terminal blocks are labeled to their corresponding wire numbers.

TORQUE TERMINALS TO 15lb-in.

USE 75°C COPPER CONDUCTORS ONLY

CONDUIT/FITTINGS TO MEET ENCLOSURE RATING

BONDING OF CONDUCTORS TO BE TIED WITH MAIN GROUND

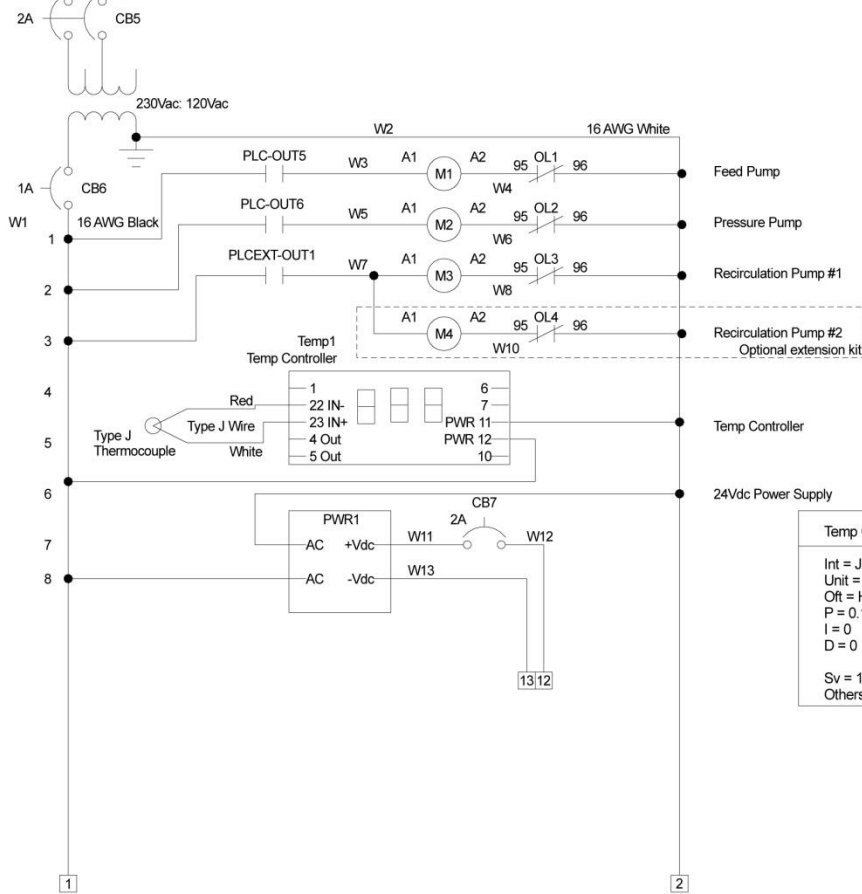

1/2

Leader Evaporator Co., Inc
40 Jernegan Drive
Swanton, VT 05488
(802) 858-5444

Drawing No. Extreme 1 sch
with optional expansion pump

#1247 Date: 5/9/2016 Rev: 5 By: SM Size: A

Note:
 - All control wire is 16 AWG Red unless otherwise noted.
 - All terminal blocks are labeled to their corresponding wire numbers.

TORQUE TERMINALS TO 15lb-in.

USE 75°C COPPER CONDUCTORS ONLY

CONDUIT/FITTINGS TO MEET ENCLOSURE RATING

BONDING OF CONDUCTORS TO BE TIED WITH MAIN GROUND

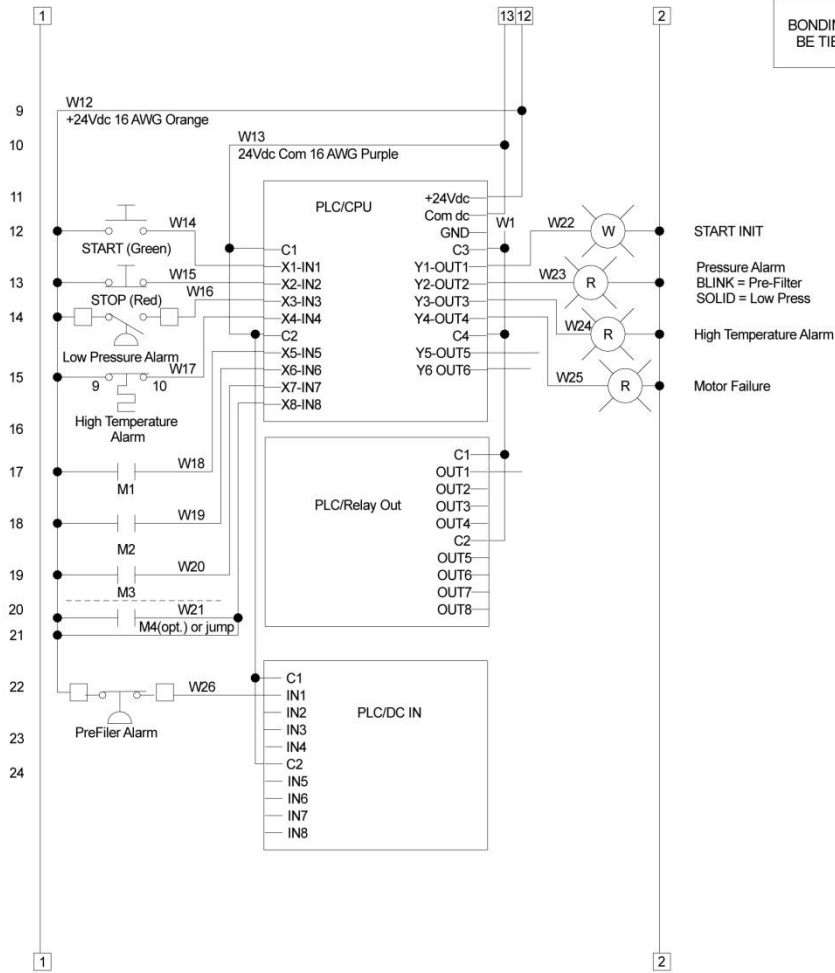

2/2

Leader Evaporator Co., Inc
 49 Jönsergen Drive
 Swanton, VT 05488
 (802) 868-5444

Drawing No. **Extreme 1 sch with optional expansion pump**

#1247 Date: 5/9/2016 Rev: 5 By: SM Size: A

ATTACHMENT #2 – OPERATIONS DATA LOGSHEET

Water Removal % = (permeate flow / (permeate flow + concentrate flow)) * 100

GPH Processed = (permeate flow + concentrate flow) * 60

SPRINGTECH EXTREME 1 OPERATIONS DATA

	DATE								
	ACTIVITY (C or T)								
SUGAR CONCENTRATION	SAP								
	CONCENTRATE								
FLOW (gpm)	PERMEATE								
	CONCENTRATE								
	TEMPERATURE								
PRESSURE (psi)	FEED PUMP								
	MEMBRANE								
	WATER REMOVAL %								
	GPH PROCESSED								

	DATE								
	ACTIVITY (C or T)								
SUGAR CONCENTRATION	SAP								
	CONCENTRATE								
FLOW (gpm)	PERMEATE								
	CONCENTRATE								
	TEMPERATURE								
PRESSURE (psi)	FEED PUMP								
	MEMBRANE								
	WATER REMOVAL %								
	GPH PROCESSED								

	DATE								
	ACTIVITY (C or T)								
SUGAR CONCENTRATION	SAP								
	CONCENTRATE								
FLOW (gpm)	PERMEATE								
	CONCENTRATE								
	TEMPERATURE								
PRESSURE (psi)	FEED PUMP								
	MEMBRANE								
	WATER REMOVAL %								
	GPH PROCESSED								

	DATE								
	ACTIVITY (C or T)								
SUGAR CONCENTRATION	SAP								
	CONCENTRATE								
FLOW (gpm)	PERMEATE								
	CONCENTRATE								
	TEMPERATURE								
PRESSURE (psi)	FEED PUMP								
	MEMBRANE								
	WATER REMOVAL %								
	GPH PROCESSED								

	DATE								
	ACTIVITY (C or T)								
SUGAR CONCENTRATION	SAP								
	CONCENTRATE								
FLOW (gpm)	PERMEATE								
	CONCENTRATE								
	TEMPERATURE								
PRESSURE (psi)	FEED PUMP								
	MEMBRANE								
	WATER REMOVAL %								
	GPH PROCESSED								

	DATE								
	ACTIVITY (C or T)								
SUGAR CONCENTRATION	SAP								
	CONCENTRATE								
FLOW (gpm)	PERMEATE								
	CONCENTRATE								
	TEMPERATURE								
PRESSURE (psi)	FEED PUMP								
	MEMBRANE								
	WATER REMOVAL %								
	GPH PROCESSED								

	DATE								
	ACTIVITY (C or T)								
SUGAR CONCENTRATION	SAP								
	CONCENTRATE								
FLOW (gpm)	PERMEATE								
	CONCENTRATE								
	TEMPERATURE								
PRESSURE (psi)	FEED PUMP								
	MEMBRANE								
	WATER REMOVAL %								
	GPH PROCESSED								

	DATE								
	ACTIVITY (C or T)								
SUGAR CONCENTRATION	SAP								
	CONCENTRATE								
FLOW (gpm)	PERMEATE								
	CONCENTRATE								
	TEMPERATURE								
PRESSURE (psi)	FEED PUMP								
	MEMBRANE								
	WATER REMOVAL %								
	GPH PROCESSED								

	DATE								
	ACTIVITY (C or T)								
SUGAR CONCENTRATION	SAP								
	CONCENTRATE								
FLOW (gpm)	PERMEATE								
	CONCENTRATE								
	TEMPERATURE								
PRESSURE (psi)	FEED PUMP								
	MEMBRANE								
	WATER REMOVAL %								
	GPH PROCESSED								

	DATE								
	ACTIVITY (C or T)								
SUGAR CONCENTRATION	SAP								
	CONCENTRATE								
FLOW (gpm)	PERMEATE								
	CONCENTRATE								
	TEMPERATURE								
PRESSURE (psi)	FEED PUMP								
	MEMBRANE								
	WATER REMOVAL %								
	GPH PROCESSED								

	DATE								
	ACTIVITY (C or T)								
SUGAR CONCENTRATION	SAP								
	CONCENTRATE								
FLOW (gpm)	PERMEATE								
	CONCENTRATE								
	TEMPERATURE								
PRESSURE (psi)	FEED PUMP								
	MEMBRANE								
	WATER REMOVAL %								
	GPH PROCESSED								



Leader Evaporator Co., Inc.
49 Jonergin Drive
Swanton, VT 05488
Tel: (802) 868-5444
Fax: (802) 868-5445
www.leaderevaporator.com

Leader Evaporator Manufacturer's Warranty For Springtech Extreme Reverse Osmosis Machines

Leader Evaporator Co., Inc. warrants our Springtech Extreme line of Reverse Osmosis Machines against any manufacturer defects for a period of two years from the date of purchase. This warranty is at the discretion of the manufacturer, Leader Evaporator Co., Inc., to be replaced or repaired, as necessary. All replaced parts become the manufacturer's property. Leader Evaporator Co., Inc. shall not be held responsible for any damage or injury arising from negligence, abuse, improper handling or installation.