

USER MANUAL

THE VORTEX



LEADER[™]
WE HELP YOU GET MAPLE DONE

LEADER EVAPORATOR
49 Jonergin Drive
Swanton, VT 05488
(802) 868-5444
LeaderEvaporator.com

CONTENTS

Contents.....	2
INTRODUCTION: THEORY OF OPERATION	3
DIAGRAM OF THE VORTEX WOOD FIRED ARCH	3
EQUIPMENT DESCRIPTION.....	4
INCLUDED PARTS	4
OPTIONAL SETUP PARTS, EQUIPMENT AND SUPPLIES	4
SETUP OF THE VORTEX WOOD FIRED ARCH	5
RECEIVING YOUR ARCH:.....	5
SUGAR HOUSE SETUP:	5
SETTING UP THE ARCH:.....	5
Foundation for the Arch:	5
Setting the Arch on a Foundation:.....	5
Powering the Arch	7
Insulating the Arch	8
INSTALL TAPER AND STACK.....	10
Roof Penetration and the Type of Roof Jack:	10
Install the Taper and Stack.....	11
PREPARING THE ARCH FOR PANS	14
OPERATING THE ARCH	15
WOOD TO USE	15
LOADING OF WOOD.....	15
WHEN TO FIRE	15
USE OF BLOWER.....	15
THE FIRST BOIL.....	16
OPERATIONS	17
DAILY SHUTDOWN	17
MAINTENANCE.....	18
Daily	18
Periodic	18
End Of Season	18
Beginning Of Season Startup	18
FEEDBACK.....	18
NOTES.....	18

INTRODUCTION: THEORY OF OPERATION

A Leader Evaporator VORTEX wood fired arch is designed to provide fuel efficient and even heating. The arch has a large combustion chamber in which air is rotated in a controlled manner to optimize the burn of the wood fuel and distribute the heat evenly. The design of the rear of the arch provides a spark trap and draft control system.



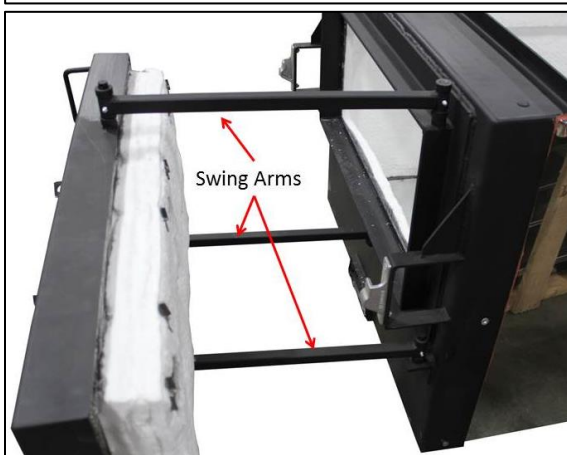
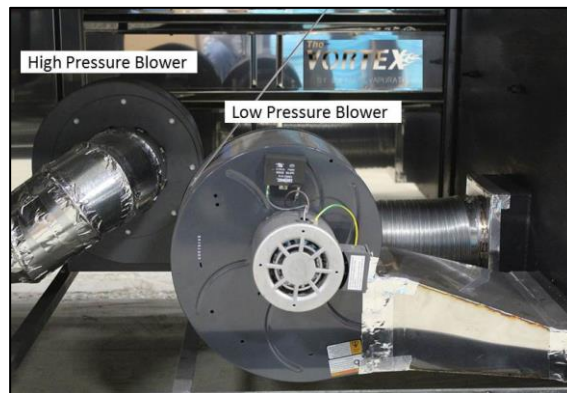
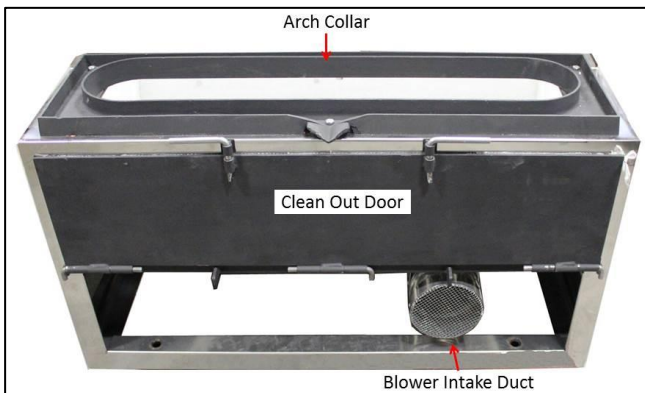



DIAGRAM OF THE VORTEX WOOD FIRED ARCH



EQUIPMENT DESCRIPTION

The Leader VORTEX arch consists of the following parts:

INCLUDED PARTS

ITEM	LEADER ORDER #	DESCRIPTION/PHOTO	ITEM	LEADER ORDER #	DESCRIPTION/PHOTO
VORTEX	Available from 2'X10' to 6'X18'		Leveling Bolt QTY: 6	68118	
Speed Control	68306		One Gang Electrical Box	68309	
Stainless Steel Base Stack	Varies with width and length of arch		Stainless Steel Stack	Varies with width and length of arch	

NOTE: LEADER EVAPORATOR supplies twice the length of the arch as a combination of the length of the base stack and the stack ex. a 2X10 arch will be supplied with a 3 foot base stack and 3 lengths of stack.

OPTIONAL SETUP PARTS, EQUIPMENT AND SUPPLIES

ITEM	LEADER ORDER #	DESCRIPTION/PHOTO	ITEM	LEADER ORDER #	DESCRIPTION/PHOTO
Stainless Steel Stack Cover	Match the diameter of the stack		Leader Style Roof Jack	Match the style and diameter of the stack	 Peak or Side of Roof Style
3000° Full Brick See Insulation Chart for quantities needed	65003		3000° Half Brick See Insulation Chart for quantities needed	65006	
Refractory Cement See Insulation Chart for quantities needed	65001		1/8" X 4" Woven Rail Gasket (sold by the foot)	65193	
Ceramic Rail Gasket (1/2" X 2" X 25')	65154		Spark Arrester	Contact LEADER Customer Service	
VORTEX Insulating Panel B (54.5" X 22")	3640001		VORTEX Insulating Panel B (63.5" X 22")	3660001	

Stack Thermometer	61052		Install at shoulder to eye level in the smoke stack			
----------------------	-------	---	--	--	--	--

SETUP OF THE VORTEX WOOD FIRED ARCH

NOTE: The following information pertaining to setup of an arch is to be considered one suggested method. Installations should meet all applicable governmental regulations and standards.

RECEIVING YOUR ARCH:

Upon receipt of the evaporator, it is recommended the following tasks be performed:

1. Protect all incoming materials from damage and the environment. If possible place the evaporator at the location where it will be setup (See section titled SUGAR HOUSE SETUP).
2. Unpack all materials and check the received materials against the Equipment Description list provided above.
3. Immediately notify Leader Evaporator or your local dealer if there are questions on the received equipment.

SUGAR HOUSE SETUP:

Prior to setup of the sugar house, it is suggested future needs be considered. If assistance is needed in determining possible future requirements please contact Leader Evaporator Sales or your local dealer.

The following are *minimum* clearances recommended for around the arch. When determining the clearances, keep in mind any additional items/equipment (ex. packaging supplies, canner, table(s), chairs) and where they will be located in the sugar house:

1. Front of the arch: six (6) feet
 - a. Allows room for firing and cleaning out of ashes
2. Back of the arch: three (3) feet
 - a. Allows for cleaning and removal of the stack
3. Sides of the arch: four (4) feet
 - a. Allows for draw off and movement

SETTING UP THE ARCH:

NOTES:

- All arch side directions are as if you were facing the fire door of the arch.
- Prior to any work, level the arch.

Foundation for the Arch:

The VORTEX arch should be placed on a standard concrete pad with footings below the frost line. The arch should not be placed on a wooden floor.

Setting the Arch on a Foundation:

1. If a roof jack has been installed, use a plumb bob to center the collar of the arch to the roof jack. If the roof jack is to be installed later reference the section titled "INSTALL TAPER AND STACK".

2. Thread the leveling bolts into the leveling bolt locations (one in each corner and one on each side). Thread the bolts halfway into the holders.

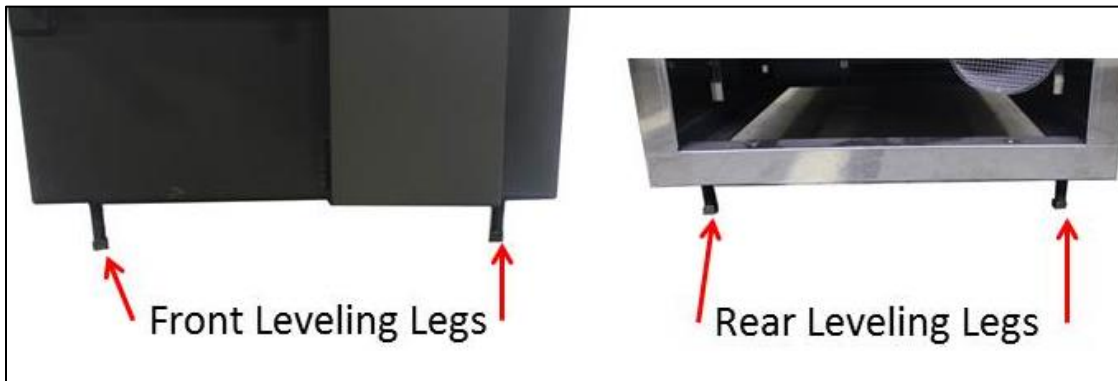

3. Level the arch on the foundation.
 - a. It is recommended a steel plate be placed under each levelling bolt to make it easier to adjust the level.
 - b. Place a 4-foot level on the rail of the arch front to back. (The rail is the part where the pans are rested).
 - c. Adjust the level of the arch by raising or lowering the leveling bolts on the four corners only.
 - d. Place the level across the arch rails of the arch side-to-side.
 - e. Adjust the level of the arch by raising or lowering the leveling bolts.
 - f. Recheck the level front-to-back.
 - g. Adjust the center bolts so they are just putting pressure on the floor.

Powering the Arch

The forced air blowers for the arch must be wired to a power source. It is recommended the electrical control box with speed control for the low pressure blower be mounted near the front of the arch. An ON/OFF switched outlet should be installed also near the front of the arch for the electrical connection plug of the high pressure blower. It is recommended an additional ON/OFF switch be added to the circuit for the low pressure blower along with the speed control. Contact a licensed electrician for installation of the speed control and switch circuits.

See the INFORMATION INSERT for specific requirements.

NOTE: When setting up the arch and when the arch is in operation make sure the intakes for the blowers are not obstructed.

NOTE: It is recommended the 1 HP blowers be on an independent electrical circuit.

Insulating the Arch

The VORTEX Wood Fired Arch is manufactured with multiple layers of 2600° insulation throughout most of the arch minimizing the bricking required. When bricking the guideline is to ensure all exposed areas of metal (except grates) are bricked as well as the areas where there are fewer layers of blanket insulation. In general the following areas will need to BE bricked:

- Right and Left sides in the area where there is less layers of blanket insulation
- The floor in front of the grates
- The floor behind the grates
- The front for the arch
 - Under 3 feet wide up to the bottom of the door
 - Over 3 feet wide up to the bottom of the door and up the sides of the door
- The floor under the collar at the rear of the arch

NOTE: LEADER EVAPORATOR offers an option for the sides of the arches. An insulating panel can be substituted for the bricks on each side of the arch.

Insulating Materials Needed

Depending on if you are using VORTEX insulating panels, the INFORMATION INSERT specifies the insulating materials needed for your arch. Note when using panels two (2) are required.

Arch Size (W X L)	FULL BRICKS	HALF BRICKS	Pails of Refractory Cement
2X10	80	26	2
30X10	91	30	2
3X10	100	34	2
40X10	103	40	3
2X12	88	26	2
30X12	98	30	2
3X12	118	34	3
40X12	118	40	3
4X12	134	44	3
30X14	114	33	3
3X14	125	36	3
40X14	124	42	3
4X14	143	45	3
5X14	166	59	4
6X14	198	64	4
40X16	139	49	3
4X16	143	50	3
5X16	193	65	4
6X16	219	72	5
5X18	200	65	4
6X18	226	72	5

General Insulating Notes:

Notes on the following drawings:

- Drawing are not to scale
- Dimensions as stated are approximate and should be determined as you brick.
- Half bricks are bricks that are ½ the thickness of a full brick.

VORTEX Side Insulation Panels

- Use caution when handling panels. Panels are heavy;
 - 54.5" X 22" (Item 3640001) – 220 pounds
 - 63.5" X 22" (Item(3660001) – 260 pounds
- Panels are set on the brick support
- No cementing is required to secure to panels

Order of Insulation:

- Sidewalls
- Floor in front of the Grates
- Floor behind the Grates
- Front
- Back of arch under the Collar

When Insulating:

- Bricks need to be rated for 3000°F
- Cover exposed steel around the grates with refractory cement
- Bricks except where noted are full bricks.
- Start a row of bricks with a full brick or a half of a full brick and work toward the end where the brick size will need to be measured.
- Apply approximately 1/16" of refractory cement to the side of the brick fitted against the arch.
- Apply approximately 1/16" of refractory cement to the sides of the brick to be fitted against brick already in place.
- Smooth refractory cement over the joints between the bricks.
- Fill in any gaps between the bricks with refractory cement.
- After bricking the side walls and prior to bricking the floor, put the grates in place. Note in the drawing how the grates are to be installed.
- When bricking the floor, place a piece of doubled over corrugated cardboard between the ends of the grates and the bricks. Cardboard can be left in place after bricking as it will burn out during the first firing.
- Allow cement to dry for 36 hours at room temperature (65°F or higher).

The following drawings detail how to insulate your arch. Locate the drawing matching your size arch and the type of insulation to be used on the sides. In the following drawings the first one shown for an arch size is one that employs all bricks. The second drawing for the arch size employs VORTEX panels for the sides.

NOTE: Pictures, sketches and drawings presented in this document are not to scale.

INSTALL TAPER AND STACK

A roof jack should be installed prior to setting up your taper and stack. Leader Evaporator offers two styles of roof jack – a Leader style that is mounted on the peak of the roof and a Leader style that is mounted on the side of the roof.

NOTE: If the roof jack was previously installed skip to the section labelled Install the Taper and Stack.

In order to determine your requirements you will need to know where you will penetrate the roof with the stack and the pitch of your roof.

Roof Penetration and the Type of Roof Jack:

- a. Obtain a plumb bob with sufficient line to reach from the roof to the stack collar of the arch.
- b. Run the plumb bob from the center of the stack collar to the roof, moving the roof point until the plumb bob is properly positioned. Ensure there are no bends in the line caused by other items.
- c. If the plumb bob line end is at the peak of the roof - order a Leader peak style roof jack. If the plumb bob line end is at the side of the roof – order a side of roof Leader style roof jack.

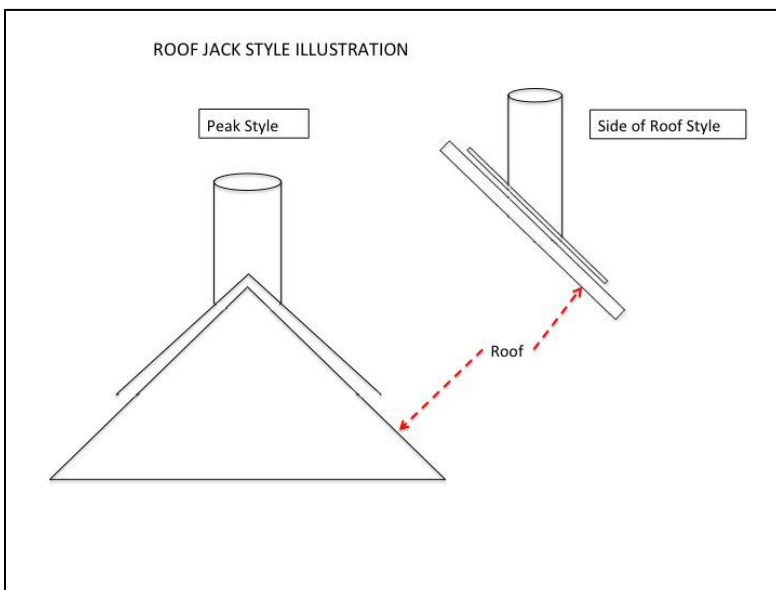

- d. Prior to taking down the plumb bob, mark the inside of the roof, as this will be used when making the roof penetration for the stack or installation of the roof jack.
- e. Roof penetration:
 - i. When installing a roof jack refer to the LEADER CUSTOMIZED ROOF JACK document.
 - ii. If not using a roof jack, make a hole at the point marked on the inside of the roof in the previous step. The hole should be large enough to allow the stack to be slid into position and as small as possible to allow for sealing to prevent rain, moisture and debris from entering the hole.

NOTE: If sealing is done directly around the stack, ensure all governmental regulations are met for this type of installation.

Install the Taper and Stack

NOTE: It is recommended you install all supplied exhaust stack, as a minimum. Additional stack may be required to ensure proper draft. Smoke stack must clear the highest peak of the roof by a minimum of 2 feet.

Draft is correct when:

- The boil is the same in the syrup pan front-to-back and side-to-side
- With the blowers off and the fire door is open the flame, sparks, etc. are drawn toward the rear of the arch.



NOTE: When working with stack sections, recognize that the crimped end of the stack section is the upper / top section.



1. OPTIONAL - Place a spark arrester over the stack collar opening.



2. Place the base taper on the arch stack collar. If you have difficulty placing the base taper onto the collar, squeeze the base taper by pressing on the long sides at the base.

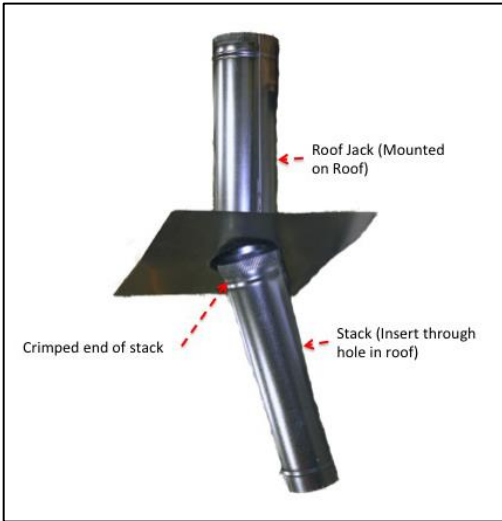

3. If a roof jack is used,

- a. Insert one piece of stack into the roof jack until it is a lightly wedged. The Leader style roof jack is tapered from larger to smaller. The end to be inserted into the roof jack is the crimped end. NOTE: You will be moving the piece of stack back down by approximately 2 ½" when you connect to the next stack section so ensure it will be able to move.

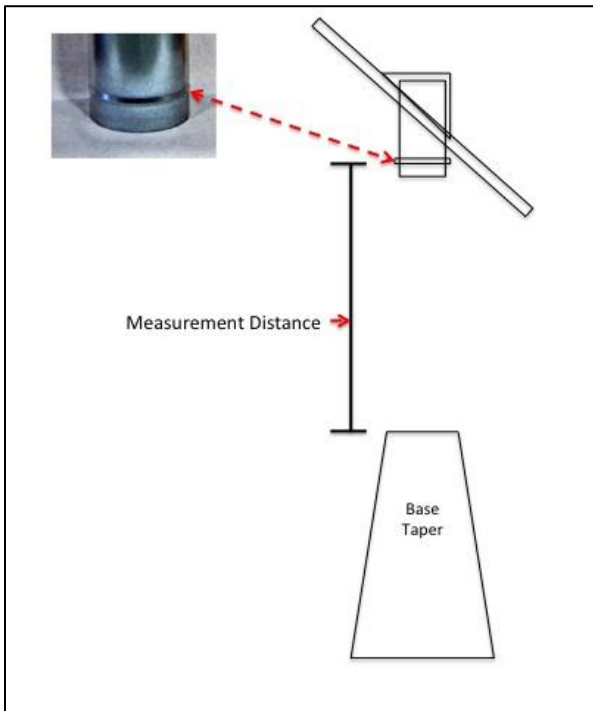

- b. Measure from the top of the taper to the bead at the bottom of the stack section in the roof jack.
- c. Determine the number of lengths of stack required by dividing the measurement taken in inches by 34".
 - i. For example if the measurement was 68", then $68" \div 34" = 2$ so 2 lengths of stack are required.
 - ii. For example if the measurement was 60", then $60" \div 34" = 1.76$ lengths of stack are required. This would mean one full length and a length measuring 26" would be required. To obtain the 26" length you can either
 - iii. Special order a piece of stack the length required
 - iv. Cut a standard length of stack to fit. If you cut a length of stack to fit, measure the length from the bead of the stack and cut off the top/crimped end.

- 4. Install the stack sections starting from the base taper. Ensure you place the crimped end up when connecting the stack sections.
- 5. When you put the last indoor section in place, lower the stack section from the roof jack (if used) approximately 2 ½" down onto the top piece of stack, or lower a stack section through the penetration in the roof.

- a. If a roof jack is used, place all remaining sections of stack onto the roof jack by placing the beaded bottom end over the top of the roof jack and aligning with the interior stack.
6. Continue installing stack until all pieces have been installed. Ensure you have a good overlap for each stack joint. Overlap will be 2 to 2 ½". It is recommended you screw all sections together using self-tapping stainless steel screws.
7. Stack above the roof should be guide wired in at least three directions (tripod configuration) to minimize the effects of wind.
 - a. It is recommended you install a stack cover on the last / top section of stack. A closed stack cover will minimize the rain and moisture entering the stack and arch. When installing a stack cover refer to the LEADER STACK COVER document.

PREPARING THE ARCH FOR PANS

The VORTEX arch requires the use of ceramic rail gasket for a better seal. Two layers of gasket are to be installed.

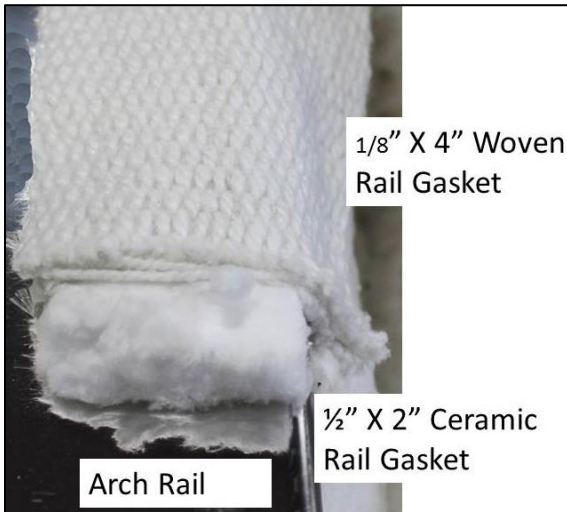

1. Cut the length of $\frac{1}{2}$ " X 2" ceramic rail gasket to line the arch rail under the pans.
2. Cut the same length of $\frac{1}{8}$ " X 4" woven gasket.
3. Lay the 4" gasket over the $\frac{1}{2}$ " gasket as shown and wrap the 4" gasket around the arch rail. The 4" gasket material can be tucked between the preinstalled wall insulation and the bottom of the arch rail in order to hold it in place.

OPERATING THE ARCH

The following items should be considered as you prepare and operate your VORTEX arch.

WOOD TO USE

The INFORMATION INSERT specifies the size of the wood to be used.

LOADING OF WOOD

The wood should be loaded to the height of the transition point where the full brick meets the half brick on the sides of the arch.

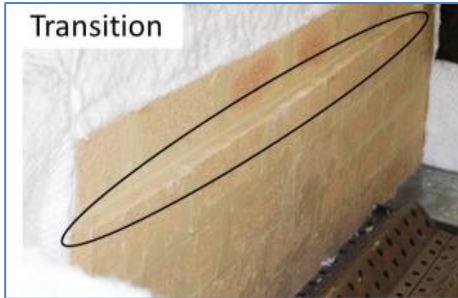

For an arch insulated with panels, load wood to approximately 4" to 5" from the top of the panels.

Use a mix of hard wood and soft wood.

Load wood onto the grates so the grates are completely covered.

WHEN TO FIRE

Fire to keep a consistent stack temperature between 800° and 1000°F.

Establish the time needed to keep the stack temperature in range. Use a timer as a reminder to fire the arch.

Depending on a number of factors such as blower adjustment and wood being used, the firing will occur every 6 to 15 minutes.

USE OF BLOWER

Prior to using the blower it must be adjusted to the rheostat as follows:



1. Turn the Motor Control clockwise as far as it will go.
2. With a fine straight bladed screwdriver, turn the Speed Adjustment Screw until the blower is just turning.
3. Turn the Motor Control counter clockwise until it reaches the maximum setting. The blower should be running at maximum.

Generally the blower is used at maximum speed. The blower speed can be lowered for increased fuel efficiency but will increase the time required for processing sap.

When firing:

- Turn the high pressure blower off.
- Turn the low pressure blower all the way down to fire the arch. Do NOT turn it off as the blower cools the grates.

THE FIRST BOIL

The first boil is done to check your setup, determine if draft is correct and to season the insulation.

1. Follow the instructions for setting up the pan set being installed on the arch.
2. Fill the flue pan and syrup pan with a baking soda: water mix (1 pound: 200 gallons to a level of 2 to 3 inches.
3. Check all fittings for leakage.
4. Open the cupola(s), thimbles and any stack covers in place.
5. Open the condensate drains on the hoods.
6. Start by building a small fire in the fire box and very gradually build to a normal fire.
7. Boil the solution for approximately 30 minutes. Watch the boil carefully and replenish the solution as needed so the liquid level remains at 2 to 3 inches.
8. Check all equipment:
 - a. No leaks in connections and valves
 - b. Pans are boiling evenly
 - c. Valves are working properly
 - d. Floats are functioning
 - e. Draft is correct
 - i. The boil in the syrup pan is the same front-to-back and side-to-side.
 - ii. When the fire door is open, the flames, ash, sparks, etc. are drawn toward the rear of the arch
9. Drain the solution after it has cooled. CAUTION – ensure the equipment is cool enough to be safely handled before draining.
10. Check the interior of the arch to ensure the insulation and bricking are properly in place.
11. Refill the pans with clean, unsoftened, non-chlorinated well or spring water.
12. Boil for 30 minutes during which time adjust the floats down to operating depths. It may take 10 to 15 minutes for the level adjustments to take full effect. After the evaporator has cooled, drain the pans. CAUTION – ensure the equipment is cool enough to be safely handled for draining.

OPERATIONS

NOTE: When operating the evaporator be cautious of hazards such as hot surfaces, hot liquids, sparks, and exposed flames.

NOTE: You must be aware at all times of the level of sap in all sections of the pans. If the level drops too low you can and will damage your pans. If there is too much foam you risk damaging your pans.

NOTE: If you have purchased a scoop or skimmer, do NOT use them to push sap through the evaporator. Doing so will change the gradient in the evaporator.

1. Check the evaporator
 - a. Make sure all sap sources are flowing freely i.e. not frozen.
 - b. Ensure defoamer is usable.
 - c. Ensure all fittings are tight.
 - d. Make sure all valves are working properly and the floats are properly positioned.
 - e. Clean the flues of the flue pan with the flue brush every 8 to 12 hours of boiling
 - f. Ensure the open area in the grates is clean and free of material
 - g. Remove the ashes from below the grates.
 - h. Open the condensate drains on the hoods.
 - i. Open the cupola(s), thimbles and stacks covers.

DAILY SHUTDOWN

1. There are two factors influencing the shutdown of the evaporator; time and sap volume.
 - a. It will require approximately 30 to 40 minutes from the last firing to bring the fire down to embers (coals on the grates) in a wood fired arch.
 - b. It will require a volume of sap from the last firing to embers and to flood the arch so ensure there is adequate volume left prior to the last firing.
2. After the last draw off and last firing draw-off “sweet”, from the evaporator into a clean container. Set the container aside and cover it. NOTE: Suggested quantities of “sweet” to draw are in the table that follows. The quantity of “sweet” should be adjusted based on experience and concentration of the sap being used.

Pan Set Width (Inches)	Gallons of “Sweet”
24	1 to 1 ½
30	1 ½ to 2
36	2 to 2 ½
40	2 ½ to 3 ½
48	3 ½ to 5
60	4 to 7
72	6 to 9

3. Continue to monitor the arch as done for normal operations.
4. When there is no more boil in either the flue or the syrup pans and the fire is down to coals on the grates, add sap until the pans are at a depth of 2”. This is done by holding the float down or by adjusting the float handles and lowering it. If the sap remaining does not cover the pans to the 2” depth then add clean, unsoftened, non-chlorinated well or spring water until the depth is reached.

NOTE: The extra sap depth is required as the insulation of the arch (ex. bricks) will hold heat and continue the evaporation process until the heat has been dissipated.

MAINTENANCE

DAILY – prior to performing maintenance make sure the surfaces have been cooled.

1. Remove spills and splashes from the pans and arch by wiping with hot water.
2. Clean out the ash chamber under the grates, beneath the stack and the ashes on top of the grates.
3. Check all fittings for leakage. Repair / replace as necessary.
4. Clean the blower intake screen at the rear of the arch.

PERIODIC

1. Inspect the rail gasket and pan gasket for areas where heat and smoke maybe escaping. Replace if necessary.
2. Lubricate door swing arms by using a grease “gun” to inject grease into the fittings on the swing arms.
3. Check the intakes for the blowers and clean as needed.
4. Inspect the spark arrestor, if used, for areas where the screen is missing. Replace if the screen grid is not intact.

END OF SEASON

1. Clean ash from the arch.
2. Inspect the insulation, bricks and grates. Replace any damaged pieces.
3. Lubricate door swing arms by using a grease “gun” to inject grease into the fittings on the swing arms.
4. Clean the intakes for the blowers.
5. Check the door gaskets (firebox and forced air duct). Replace if worn or if leakage is noted.
6. Inspect the spark arrestor, if used, for areas where the screen is missing. Replace if the screen grid is not intact.
7. Set 2X4s across the rail of the arch where the flue pan is usually placed then set the flue pan right side up on the 2X4s.
8. Set 2X4s across the rail of the arch where the syrup pan is usually placed then set the syrup pan right side up on the 2X4s.
9. Cover the pans and arch with plastic or a tarp.

BEGINNING OF SEASON STARTUP

1. Remove the cover and take the pans and 2X4s off from the arch.
2. Install a new rail gasket.
3. Place the pans on the arch and install a new pan gasket between the pans.
4. Assemble the pan set being used.
5. Wipe and/or rinse out the pans.
6. When filling the pans for the first time check all fittings for leakage and repair if necessary.
7. Check condensate drains.
8. Check thimbles, stack, stack cover and cupola operation.

FEEDBACK

Please use the following e-mail address (feedback@leaderevaporator.com) to suggest improvements or enter comments on this document. Reference the document title in your note. You may also contact LEADER Customer Service.

NOTES